

BACKUP Service Manual

AUTOMATIC TRANSMISSION

1992 – 1993

FOREWORD

The information contained in this service manual has been prepared for the professional automotive technician involved in daily repair operations. Information in this manual is divided into groups by transaxle or transmission models. Each group is further divided to address individual components within the group.

These groups contain general information, specification, removal and installation, disassembly and reassembly procedures for the components. The first page of each group contains an alphabetical index to assist in finding the location of the component. The information, descriptions and specifications were in effect at the time this manual was released.

This BACKUP DSM manual is to be used ONLY as a BACKUP. Please DO NOT REDISTRIBUTE WHOLE SECTIONS. This BACKUP was sold to you under the fact that you do indeed OWN a GENUINE DSM MANUAL. It CANNOT BE considered a REPLACEMENT (Unless your original manual was lost or destroyed.)

Please See README.TXT or README.HTML for additional information

Thank you. Gimmiemymanual@hotmail.com



Mitsubishi Motors Corporation reserves the right to make changes in design or to make additions to or improvements in its products without imposing any obligations upon itself to install them on its products previously manufactured.

GROUP INDEX

Introduction

Automatic Transaxle

F3A2

F4A2

F4A3, W4A3

23A

23B

23C

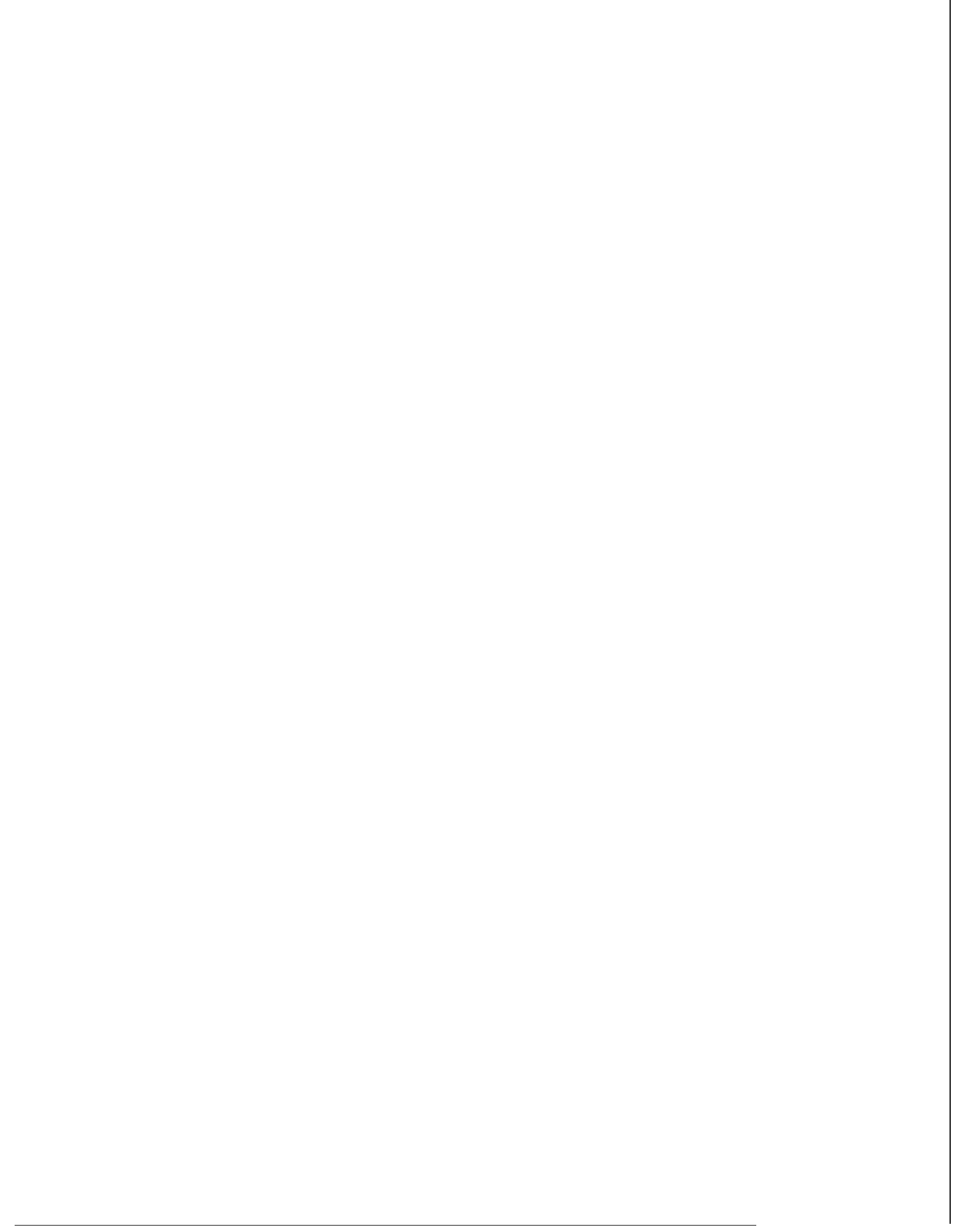

INTRODUCTION

CONTENTS

EXPLANATION OF MANUAL CONTENTS	2	SPECIAL TOOL NOTE	5
FORM-IN-PLACE GASKET	6	TORQUE REFERENCES	5
Disassembly	6	TRANSAXLE/TRANSMISSION MODEL TABLE	4
Form-In-Place Gasket Application	6		
Surface Preparation	6		



EXPLANATION OF MANUAL CONTENTS

Maintenance and Servicing Procedures

- (1) A diagram of the component parts is provided near the front of each section in order to give the reader a better understanding of the installed condition of component parts.
- (2) The numbers provided within the diagram indicate the sequence for maintenance and servicing procedures; the symbol **N** indicates a non-reusable part; the tightening torque is provided where applicable.

- **Removal steps:**
The part designation number corresponds to the number in the illustration to indicate removal steps.
- **Disassembly steps:**
The part designation number corresponds to the number in the illustration to indicate disassembly steps.
- **Installation steps:**
Specified in case installation is impossible in reverse order of removal steps. Omitted if installation is possible in reverse order of removal steps.
- **Reassembly steps:**
Specified in case reassembly is impossible in reverse order of disassembly steps. Omitted if reassembly is possible in reverse order of disassembly steps.





Classification of Major Maintenance/Service Points

When there are major points relative to maintenance and servicing procedures (such as essential maintenance and service points, maintenance and service standard values, information regarding the use of special tools, etc.), these are arranged together as major maintenance and service points and explained in detail.

- ◁A▷: Indicates that there are essential points for removal or disassembly.
 ▶A◀: Indicates that there are essential points for installation or reassembly.

Symbols for Lubrication, Sealants and Adhesives

Information concerning the locations for lubrication and for application of sealants and adhesives is provided, by using symbols, in the diagram of component parts, or on the page following the component parts page, and explained.

-  Grease
(multipurpose grease unless there is a brand or type specified)
-  Sealant or adhesive
-  Brake fluid, automatic transmission fluid or air conditioner compressor oil
-  Engine oil or gear oil

Indicates the group title. Indicates the section title. Indicates the group number. indicates the page number.

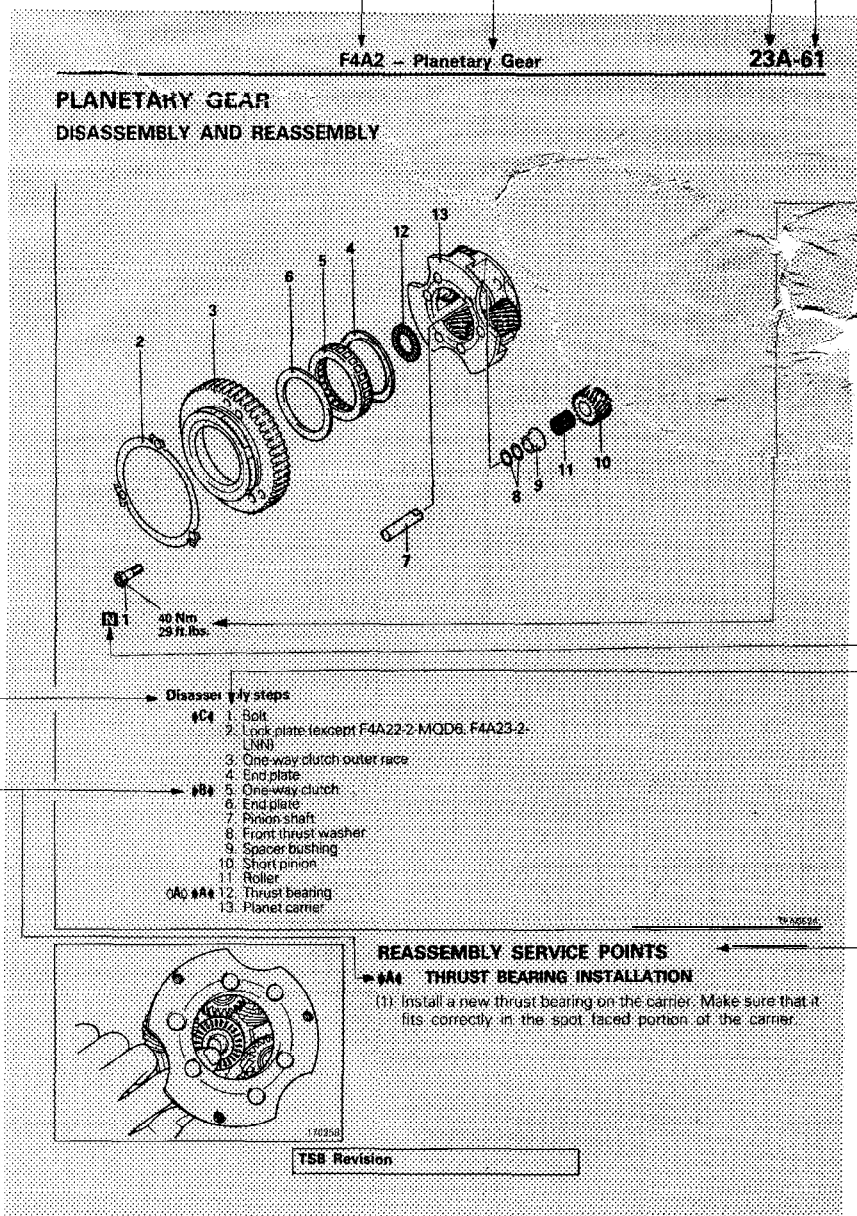

Denotes tightening torque.

Denotes non-reusable part.

This number corresponds to the number appearing in "Removal steps", "Disassembly steps", "Installation steps" or "Reassembly steps".

Operating procedures, cautions, etc. on removal, installation, disassembly and reassembly are described.

TRANSAXLE/TRANSMISSION MODEL TABLE – MODEL 1992

Model Code	Type	Diff.	Center Diff.	vcu	Center Diff. Lock	Vehicle Model
F3A21	FWD, 3-speed	X	–	–	–	Mirage
F4A21	FWD, 4-speed	X	–	–	–	Mirage
F4A22		X	–	–	–	Expq-LRV, Galant, Eclipse
F4A23		X	–	–	–	Expo
F4A33		X	–	–	–	Eclipse, 3000GT
W4A32		Full time 4WD, 4-speed	X	X	X	–
W4A33	X		X	X	–	Eclipse
V4AW2	Part time 4WD, 4-speed	–	X	X	X	Montero
R4AC1	RWD, 4-speed	–	–	–	–	Truck

Diff.: Differential
VCU: Viscous Coupling
FWD: Front wheel drive
RWD: Rear wheel drive
4WD: Four wheel drive

TRANSAXLE/TRANSMISSION MODEL TABLE – MODEL 1993

Model Code	Type	Diff.	Center Diff.	VCU	Center Diff. Lock	Vehicle Model
F3A21	FWD, 3-speed	X	–	–	–	Mirage
F4A22	FWD, 4-speed	X	–	–	–	Mirage, Expo-LRV, Galant, Eclipse
F4A23		X	–	–	–	Expo, Expo-LRV
F4A33		X	–	–	–	Eclipse, 3000GT
W4A32		Full time 4WD, 4-speed	X	X	X	–
W4A33	X		X	X	–	Eclipse
V4AW2	Part time 4WD, 4-speed	–	X	X	X	Montero
R4AC1	RWD, 4-speed	–	–	–	–	Truck

Diff : Differential
VCU: Viscous Coupling
FWD: Front wheel drive
RWD: Rear wheel drive
4WD: Four wheel drive

SPECIAL TOOL NOTE

Please refer to the special tool cross reference chart which is located in the service manual at the beginning of each group, for a cross reference from the MMC special tool number to the special tool number that is available in your market.

TORQUE REFERENCES

General tightening torque is as shown in the following table.
The specific part tightening torque is shown at the beginning of each group.

Size mm (dia. x pitch)	Bolt with spring washer						Flange bolt			
	Head mark 4		Head mark 7		Head mark 10		Head mark 4		Head mark 7	
	Nm	ft.lbs.	Nm	ft.lbs.	Nm	ft.lbs.	Nm	ft.lbs.	Nm	ft.lbs.
5 x 0.8	—	—	5.0	4	—	—	—	—	6.0	4
6 x 1.0	—	—	9.0	7	13	9	—	—	11	8
8 x 1.25	11	8	18	13	30	22	14	10	24	17
10 x 1.25	20	14	34	25	60	43	30	22	50	36
12 x 1.25	36	26	62	45	108	78	55	40	90	65
14 x 1.5	55	40	92	67	175	127	—	—	—	—

FORM-IN-PLACE GASKET

The transaxle and transmission have several areas where the form-in-place gasket (FIPG) is in use. To ensure that the gasket fully serves its purpose, it is necessary to observe some precautions when applying the gasket. Bead size, continuity and location are of paramount importance. Too thin a bead could cause leaks. Too thick a bead, on the other hand, could be squeezed out of location, causing blocking or narrowing of the fluid feed line. To eliminate the possibility of leaks from a joint, therefore, it is absolutely necessary to apply the gasket evenly without a break, while observing the correct bead size.

The FIPG used in the transaxle and transmission is a room temperature vulcanization (RTV) type and is supplied in a 120-gram tube (Part No. MD997740). Since the RTV hardens as it reacts with the moisture in the atmospheric air, it is normally used in the metallic flange areas.

Disassembly

The parts assembled with the FIPG can be easily disassembled without use of a special method. In some cases, however, the sealant between the joined surfaces may have to be broken by lightly striking with a mallet or similar tool. A flat gasket scraper may be lightly hammered in between the joined surfaces. In this case, however, care must be taken to prevent damage to the joined surfaces.

Surface Preparation

Thoroughly remove all substances deposited on the gasket application surfaces, using a gasket scraper or wire brush. Check to ensure that the surfaces to which the FIPG is to be applied is flat. Make sure that there are no oils, greases and foreign substances deposited on the application surfaces. Do not forget to remove the old sealant remained in the bolt holes.

Form-In-Place Gasket Application

When assembling parts with the FIPG, you must observe some precautions, but the procedure is very simple as in the case of a conventional pre-cut gasket.

Applied FIPG bead should be of the specified size and without breaks. Also be sure to encircle the bolt hole circumference with a completely continuous bead. The FIPG can be wiped away unless it is hardened. While the FIPG is still moist (in less than 15 minutes), mount the parts in position. When the parts are mounted, make sure that the gasket is applied to the required area only.

The FIPG application procedure may vary on different areas. Observe the procedure described in the text when applying the FIPG.

AUTOMATIC TRANSAXLE

F3A21

CONTENTS

ANNULUS GEAR AND TRANSFER		SPECIFICATIONS	7
DRIVE GEAR SET	54	Adjusting Pressure Plate, Snap Rings and Spacers	9
DIFFERENTIAL	56	Gear Ratio Table	7
DRIVE SHAFT OIL SEAL	61	Service Specifications	7
FRONT CLUTCH	46	Transaxle Model Table	7
GENERAL INFORMATION	2	Torque Specifications	11
KICKDOWN SERVO	58	Valve Body Spring Identification	8
LOW-REVERSE BRAKE	59	SPEEDOMETER GEAR	60
OIL PUMP	44	TRANSAXLE	15
PLANETARY GEAR	51	TRANSFER SHAFT / GOVERNOR	62
REAR CLUTCH	48	VALVE BODY	63
SPECIAL TOOLS	12		

GENERAL INFORMATION

Precautions to be taken when disassembling and reassembling the transmission

- Because the automatic transaxle is composed of component parts of an especially high degree of precision, these parts should be very carefully handled during disassembly and assembly so as not to scar or scratch them.
- A rubber mat should be placed on the workbench, and it should always be kept clean.
- During disassembly, cloth gloves or shop towels should not be used. If such items must be used, either use articles made of nylon, or use paper towels.
- All disassembled parts must be thoroughly cleaned.
Metal parts may be cleaned with ordinary detergents, but must be thoroughly air dried.
- Clean the clutch disc, resin thrust plate and rubber parts by using ATF (automatic transmission fluid), being very careful that dust, dirt, etc. do not adhere to them.
- Do not reuse gaskets, oil seals, or rubber parts.
Replace such parts with new ones at every reassembly. The O-ring of the oil level gauge need not be replaced.
- Do not use grease other than petrolatum jelly.
- Apply ATF to friction components, rotating parts, and sliding parts before installation.
- A new clutch disc should be immersed in ATF for at least two hours before installation.
- Do not apply sealer or adhesive to gaskets.
- When a bushing must be replaced, replace the assembly in which it is incorporated.
- If the transaxle main unit is damaged, also disassemble and clean the cooler system.

SECTIONAL VIEW – MODEL 1992

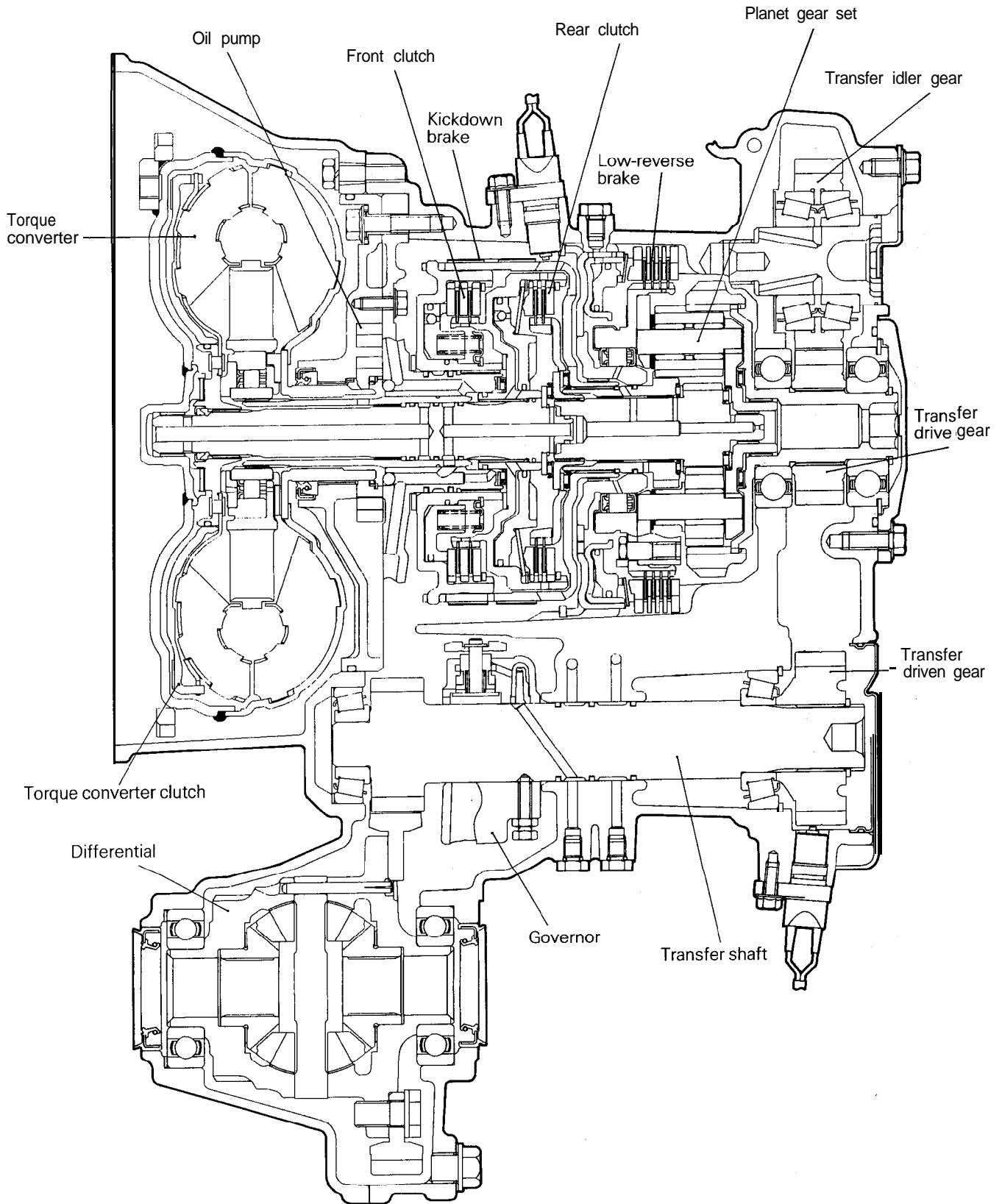

SECTIONAL VIEW – MODEL 1993

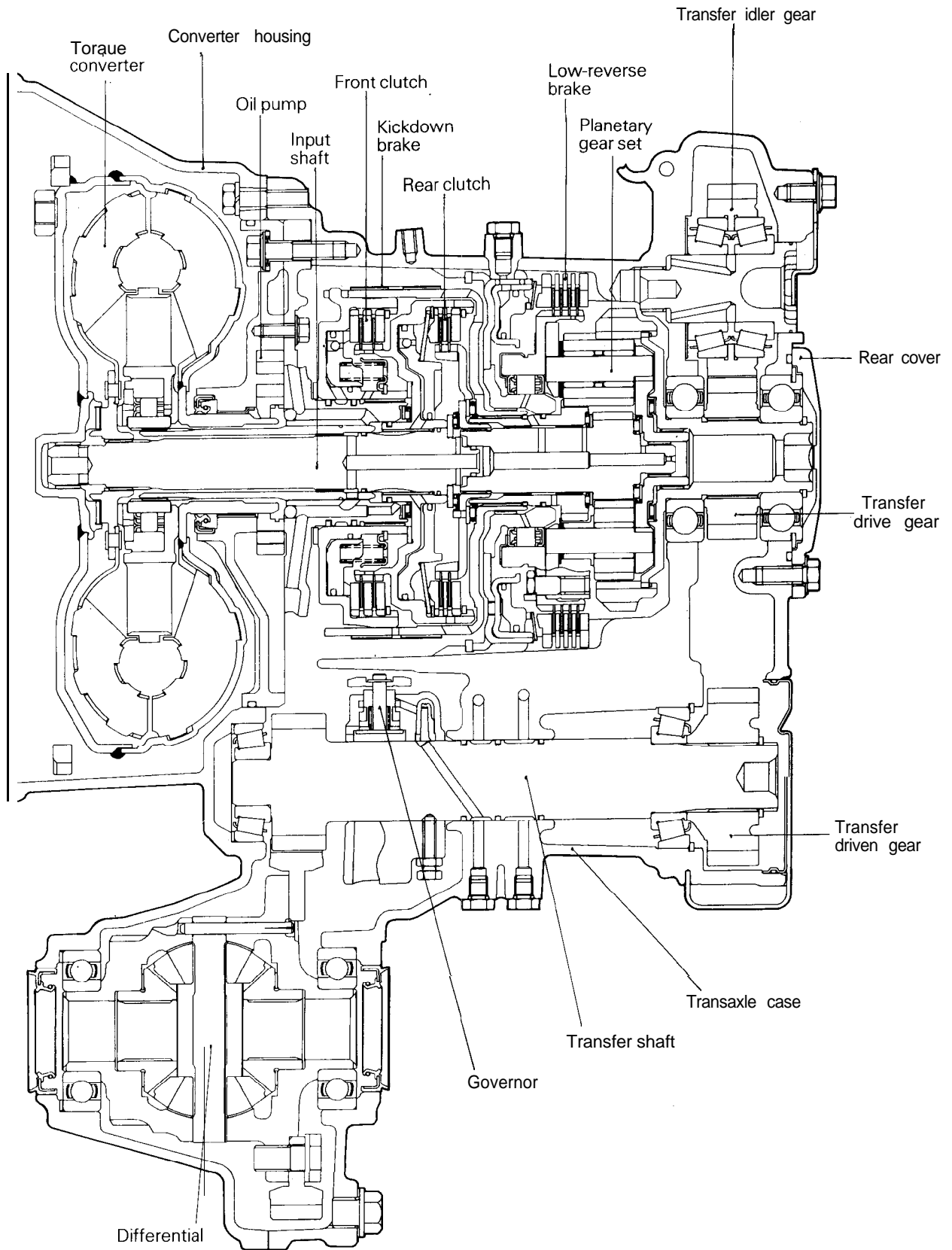

HYDRAULIC CONTROL SYSTEM - MODEL 1992

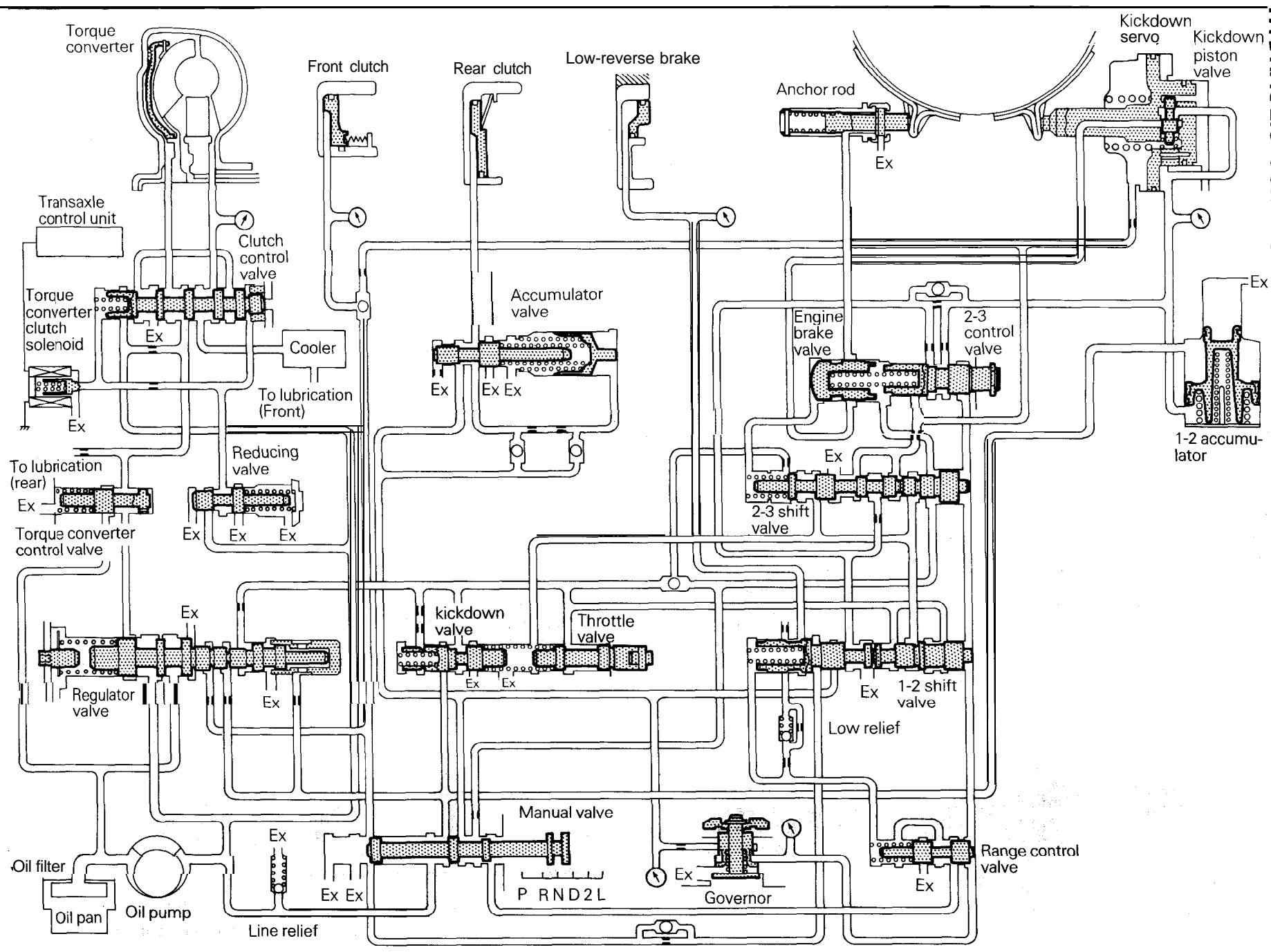

TSB Revision

HYDRAULIC CONTROL SYSTEM – MODEL 1993

TFA0057

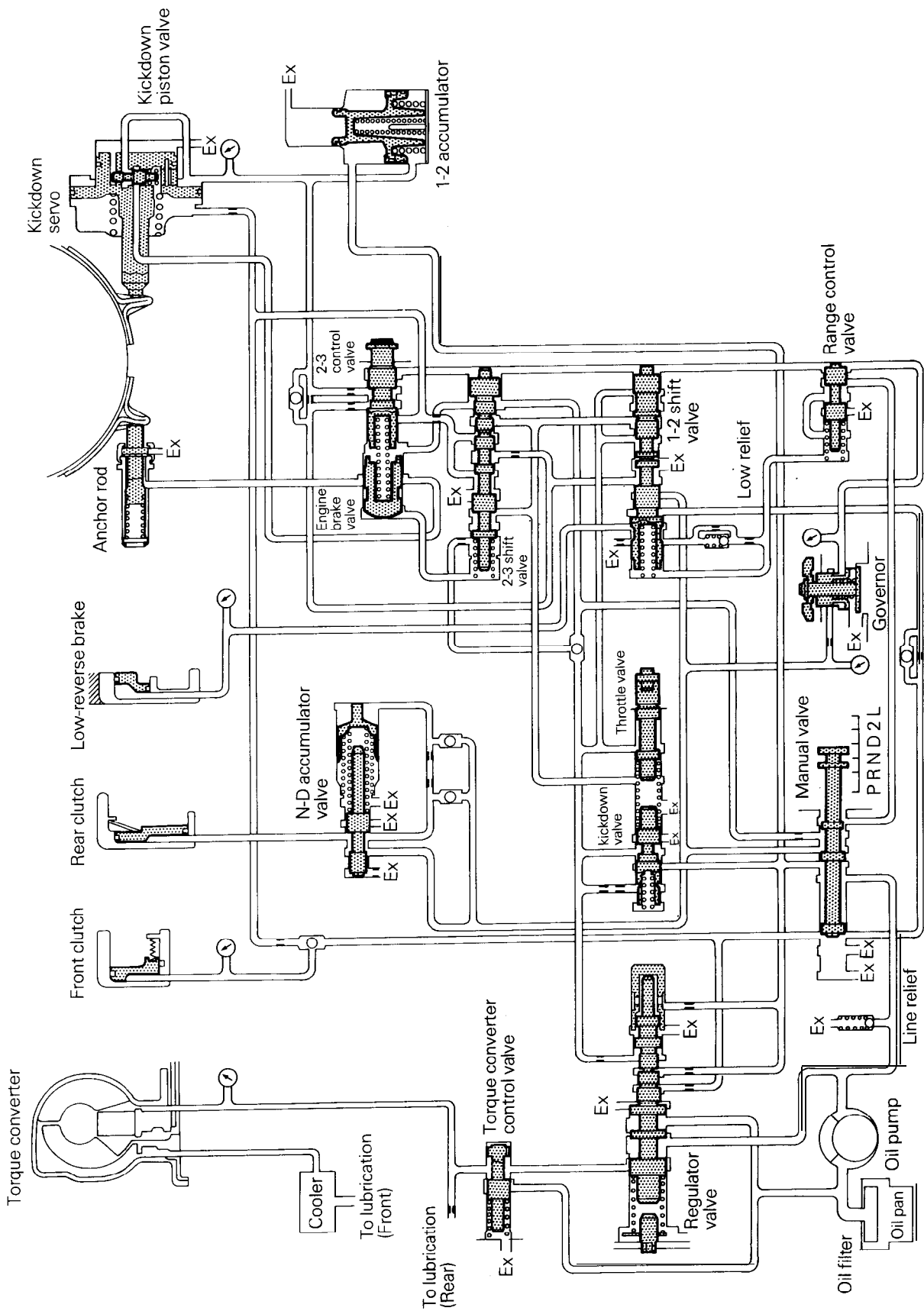

SPECIFICATIONS

TRANSAXLE MODEL TABLE – MODEL 1992

Transaxle model	Gear ratio type	Speedometer gear ratio	Final gear ratio	Vehicle model	Engine model
F3A21-2-ERA4*1	A	31/36	3.600	C52A	4G15

NOTE

*1: Model with torque converter clutch (TCC)

TRANSAXLE MODEL TABLE – MODEL 1993

Transaxle model	Gear ratio type	Speedometer gear ratio	Final gear ratio	Vehicle model	Engine model
F3A21-2-ER18	A	31/36	3.600	CA2A, CB2A	4G15

GEAR RATIO TABLE

	A
1 st	2.846
2nd	1.581
3rd	1.000
Reverse	2.176

SERVICE SPECIFICATIONS

mm (in.)

	Standard
Transfer idler gear bearing preload Nm (ft.lbs.)	0.8 (.6)
Input shaft end play	0.3 – 1.0 (.012 – .039)
Transfer shaft preload	0.1 -0.15 (.004 – .006)
Low-reverse brake end play	0.8 – 1.0 (.031 – .039)
Differential case end play	0 – 0.15 (0 – .006)
Oil pump gear side clearance	0.03 – 0.05 (.001 – .002)
Front clutch snap ring clearance	0.4 – 0.6 (.016 – .023)
Rear clutch snap ring clearance	0.3 – 0.5 (.012 – .020)
Output flange bearing end play	0 – 0.06 (0 – .002)
Differential pinion backlash	0.025 – 0.150 (.001 – .006)

VALVE BODY SPRING IDENTIFICATION

mm (in.)

Spring	Free height	Outside diameter	Number of loops	Wire diameter
Throttle valve spring	32.05 (1.262)	9.5 (.374)	12	1.0 (.039)
Kickdown valve spring	26.14 (1.029)	6.4 (.252)	19	0.5 (.020)
Range control valve spring	23.44 (.923)	8.4 (.331)	11	1.0 (.039)
Torque converter control valve spring	26.4 (1.039)	8.8 (.346)	12	1.1 (.043)
Regulator valve spring	51.4 (2.024)	15.4 (.606)	12	1.4 (.055)
1-2 shift valve spring	31.3 (1.232)	7.6 (.299)	10	0.6 (.024)
2-3 control valve spring	50.80 (2.000)	6.6 (.260)	29	0.9 (.035)
2-3 shift valve spring	23.71 (.933)	7.2 (.283)	14	0.9 (.035)
Line relief spring	17.3 (.681)	7.0 (.276)	10	1.0 (.039)
Low relief spring	12.46 (.491)	6.6 (.260)	8	0.6 (.024)
N-D accumulator valve spring	51.92 (2.044)	7.8 (.307)	25	0.8 (.031)
N-D accumulator plug spring	37.39 (1.472)	13.6 (.535)	12	1.4 (.055)
Reducing valve spring <MODEL 1992 only>	40.35 (1.589)	6.8 (.268)	22	0.8 (.031)
Clutch control valve spring <MODEL 1992 only>	15.7 (.618)	6.2 (.244)	11	0.7 (.026)

ADJUSTMENT PRESSURE PLATE, SNAP RINGS AND SPACERS

Part name	Thickness mm (in.)	Identification symbol	Part No.
Pressure plate (For adjustment of low-reverse brake end play)	5.6 (.220)	56	MD731720
	5.7 (.224)	57	MD731 721
	5.8 (.228)	58	MD727801
	5.9 (.232)	59	MD731 000
	6.0 (.236)	60	MD727802
	6.1 (.240)	61	MD731 001
	6.2 (.244)	62	MD727803
	6.3 (.248)	63	MD731 002
	6.4 (.252)	64	MD727804
	6.5 (.256)	65	MD731 003
	6.6 (.260)	66	MD727805
	6.7 (.264)	67	MD731004
	6.8 (.268)	68	MD731 005
Snap ring (For adjustment of front clutch and rear clutch clearance)	1.6 (.063)	None	MD955630
	1.7 (.067)	Brown	MD730930
	1.8 (.071)	Blue	MD955631
	1.9 (.075)	None	MD730931
	2.0 (.079)	Brown	MD955632
	2.1 (.083)	Blue	MD730932
	2.2 (.087)	None	MD955633
	2.3 (.091)	Brown	MD730933
	2.4 (.094)	Blue	MD955634
	2.5 (.098)	None	MD730934
	2.6 (.102)	Brown	MD955635
	2.7 (.106)	Blue	MD730935
	2.8 (.110)	None	MD955636
2.9 (.114)	Brown	MD730936	
3.0 (.118)	Blue	MD955637	
Snap ring (For adjustment of output flange end play)	1.88 (.074)	None	MD707501
	1.94 (.076)	Brown	MD707502
	2.00 (.079)	Blue	MD707503
	2.06 (.081)	None	MD707504
Spacer (For adjustment of transfer shaft preload)	0.82 (.032)	82	MD71 2638
	0.85 (.033)	85	MD71 2639
	0.88 (.035)	88	MD71 2640
	0.91 (.036)	91	MD71 2641
	0.94 (.037)	94	MD71 2642
	0.97 (.038)	97	MD71 2643
	1.00 (.039)	00	MD7 12644
	1.03 (.041)	03	MD71 2645
1.06 (.042)	06	MD71 2646	



Part name	Thickness mm (in.)	Identification symbol	Part No.
Spacer (For adjustment of transfer shaft preload)	11.09 (.044)	09 12	MD71MD71 2647 2648
	1.15 (.045)	15	MD71 2649
	1.18 (.046)	18	MD71 2650
	1.21 (.048)	21	MD712651
	1.24 (.049)	24	MD71 2652
	1.27 (.050)	27	MD71 2653
	1.30 (.051)	30	MD71 2654
	1.33 (.052)	33	MD7 12655
	1.36 (.054)	36	MD71 2656
	1.39 (.055)	39	MD71 2657
	1.42 (.056)	42	MD71 2658
	1.45 (.057)	45	MD71 2659
	1.48 (.058)	48	MD71 2660
	1.51 (.059)	51	MD71 2661
	1.54 (.061)	54	MD71 2662
	1.57 (.062)	57	MD71 2663
	1.60 (.063)	60	MD71 2664
1.63 (.064)	63	MD71 2665	
1.66 (.065)	66	MD71 2666	
1.69 (.067)	69	MD71 2667	
Spacer (For adjustment of differential case end play)	1.31 (.052)	E	MD706574
	1.40 (.055)	None	MD706573
	1.49 (.059)	C	MD706572
	1.58 (.062)	B	MD706571
	1.67 (.066)	A	MD706570
	1.76 (.069)	F	MD706575
	1.85 (.073)	H	MD700272
	1.94 (.076)	c c	MD71 5956
	2.03 (.080)	FF	MD71 5959
2.12 (.083)	ll	MD71 5962	
Spacer (For adjustment of differential pinion backlash)	0.75 – 0.82 (.030 – .032)	—	MA1 80862
	0.83 – 0.92 (.033 – .036)	—	MA1 80861
	0.93 – 1.00 (.037 – .039)	—	MA1 80860
	1.01 – 1.08 (.040 – .043)	—	MA1 80875
	1.09 – 1.16 (.043 – .047)	—	MA1 80876



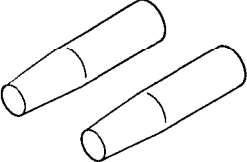
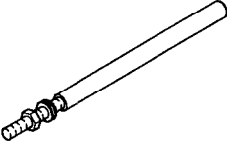
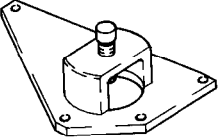
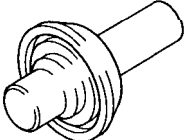
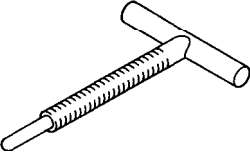
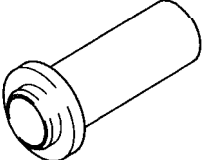
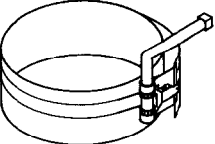
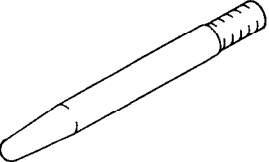
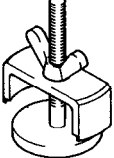

TORQUE SPECIFICATIONS

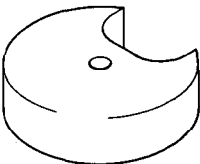
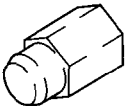
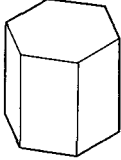
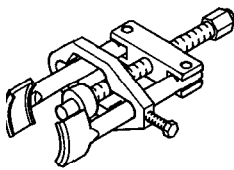
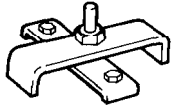
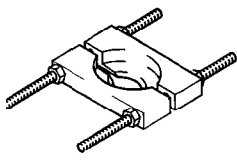
	Nm	ft.lbs.
Manual control shaft set screw	9	7
Sprag rod support bolts	24	18
Idler shaft lock plate bolt	24	18
Bearing retainer bolts	19	14
Oil pump assembly mounting bolts	21	16
Converter housing bolts	21	16
Valve body assembly mounting bolts	11	8
Oil filter bolts	6	5
Oil pan bolts	11	8
Park/neutral position switch bolts	11	8
Manual control lever nut	19	14
Pump housing to reaction shaft support bolts	11	8
Differential drive gear bolts	135	98
One-way clutch outer race lock plate bolts	40	29
Valve body bolts	5	4
Pressure check plug	9	7
Speedometer sleeve locking plate bolt	4	3
Drain plug	33	24
Throttle cam bolt	9	7
End cover bolts	5	4
Governor set screw	9	7

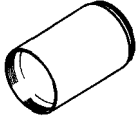
SPECIAL TOOLS

Tool	Number and tool name	Replaced by OTC tool number	Application
	MD998266 Guide pins	MD998266-01	Alignment of intermediate plate and valve body
	MD998316 Dial gauge support	MIT209038	Measurement of low-reverse brake end play
	MD998319 Transfer shaft retainer	MD998319-01	Installation of transfer shaft rear bearing and gear
	MD998325 Differential oil seal installer	MD998325-01	Installation of differential oil seal
	MD998333 Oil pump remover	MD998333-01	Removal of oil pump
	MD998334 Oil seal installer	MD998334-01	Installation of oil pump oil seal
	MD998335 Oil pump band	MD998335-01	Installation of oil pump
	MD998336 Guide pin	MD998336-01	Alignment of oil pump housing and reaction shaft support
	MD998337 Spring compressor	MD998337-01	Use with MD998338, MD998907

Tool	Number and tool name	Replaced by OTC tool number	Application
	MD998338 Spring compressor	MD998338	Disassembly of rear clutch
	MD998343 Wrench adapter	MD998343-01	Preload measurement of transfer idler shaft
	MD998344 Wrench adapter "B"	MD998344-01	Removal and installation of transfer idler shaft
	MD998348 Bearing puller	MD998348-01	Removal of bearing
	MD998365 Kickdown servo cover remover	General service tool	Removal of kickdown servo cover
	MD998301 Bearing remover	MD998348-01	Removal of bearing
	MD998812 Installer cap	General service tool	Use with installer and installer adapter
	MD998813 Installer-I 00	General service tool	Use with installer cap and installer adapter

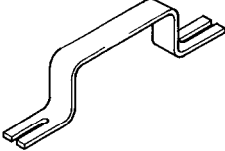
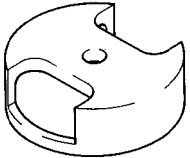
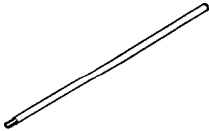
Tool	Number and tool name	Replaced by OTC tool number	Application
	MD998815 Installer adapter (26)	General service tool	Installation of each bearing
	MD998818 Installer adapter (38)		
	MD998819 Installer adapter (40)		
	MD998820 Installer adapter (42)		
	MD998905 Handle	MD998905-01	Removal and installation of center support
	MD998907 Spring compressor	MD998907-01	Disassembly and reassembly of front clutch
	MD998913 Dial gauge extension	MD998913-01	Measurement of low-reverse brake end play

TRANSAXLE

- 1. Torque converter
- 2. Converter housing
- 3. Gasket
- 4. Oil pump
- 5. O-ring
- 6. Gasket
- 7. Thrust washer #1
- 8. Front clutch assembly
- 9. Thrust race #3
- 10. Thrust bearing #4
- 11. Thrust washer #2
- 12. Rear clutch assembly
- 13. Spacer
- 14. Differential

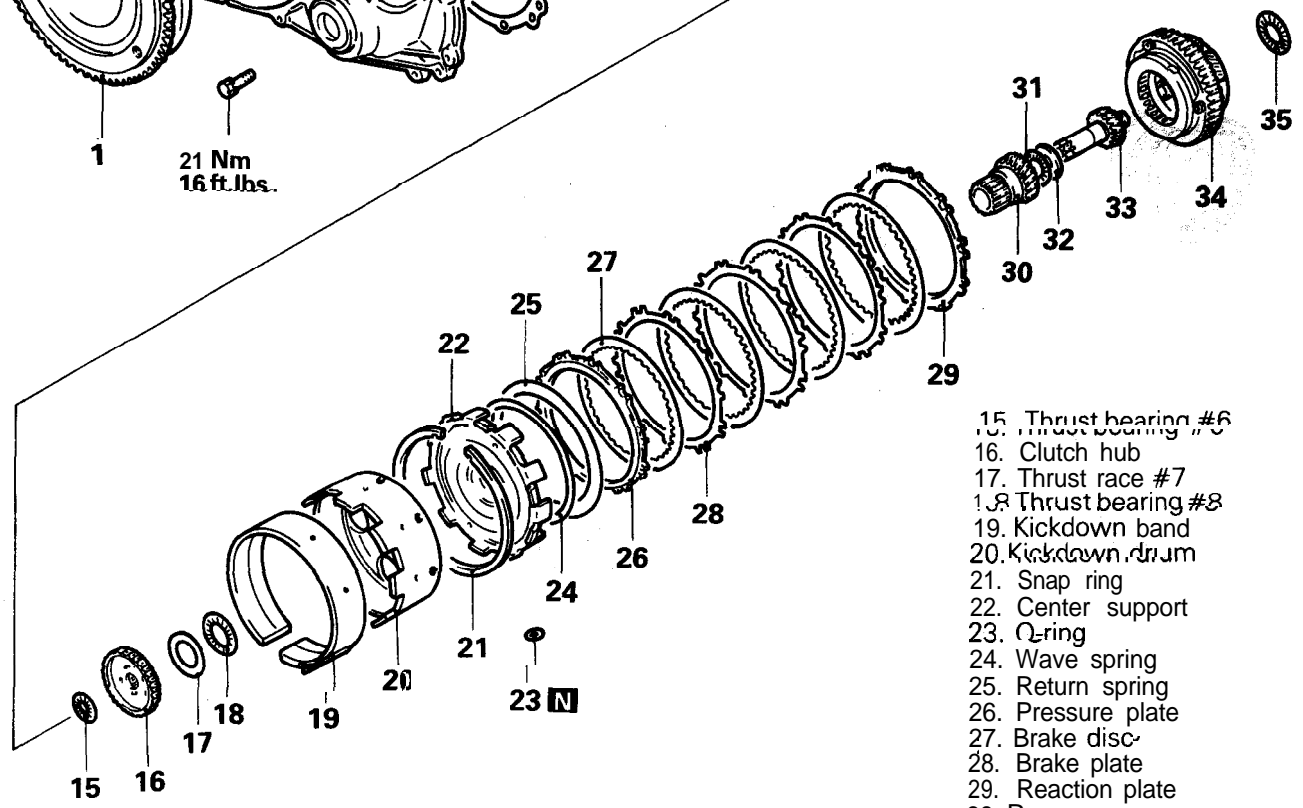
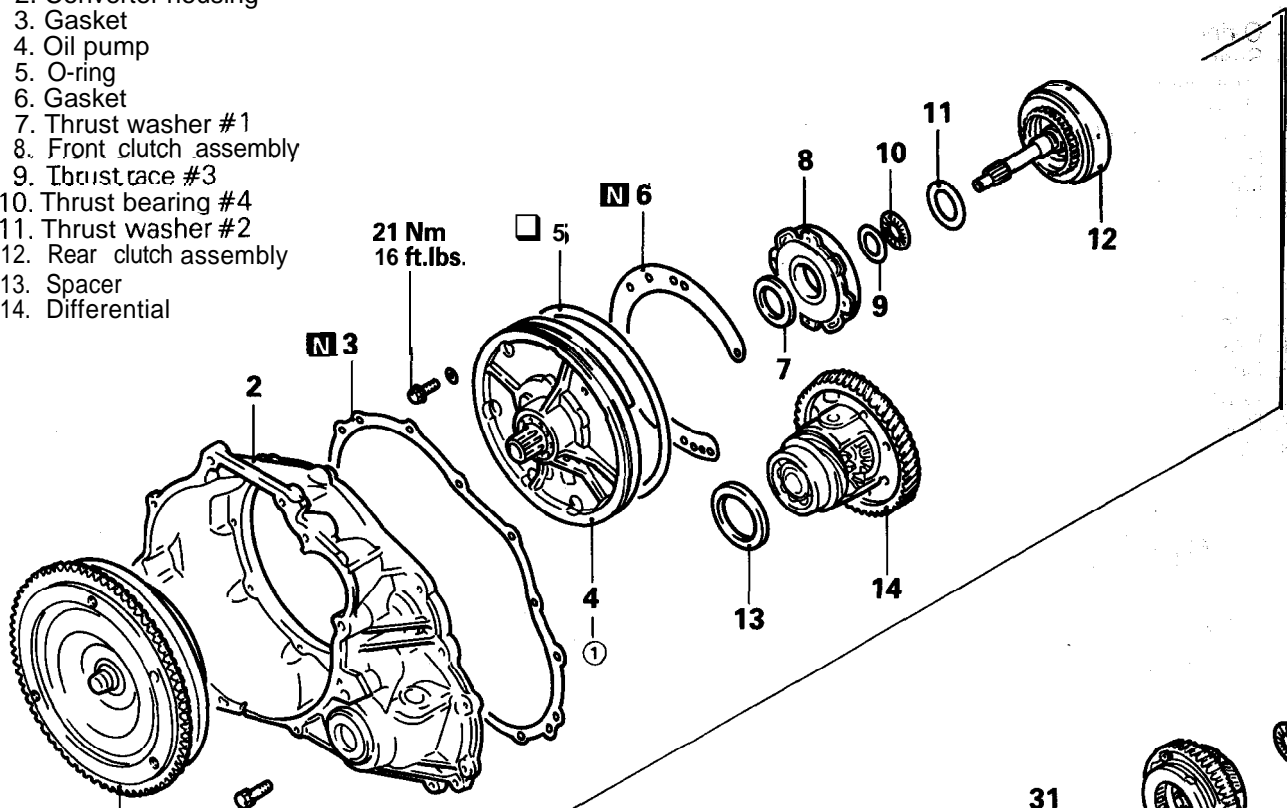

- 15. Thrust bearing #6
- 16. Clutch hub
- 17. Thrust race #7
- 18. Thrust bearing #8
- 19. Kickdown band
- 20. Kickdown drum
- 21. Snap ring
- 22. Center support
- 23. O-ring
- 24. Wave spring
- 25. Return spring
- 26. Pressure plate
- 27. Brake disc
- 28. Brake plate
- 29. Reaction plate
- 30. Reverse sun gear
- 31. Thrust bearing #9
- 32. Thrust race #10
- 33. Forward sun gear
- 34. Planetary carrier
- 35. Thrust bearing #12

- 36. Control cable
- 37. Spring washer
- 38. Control lever
- 39. Clamp
- 40. Park/neutral position switch (PNP switch)
- 41. Bearing retainer
- 42. O-ring
- 43. Snap ring
- 44. Lock plate
- 45. O-ring
- 46. Idler gear shaft
- 47. Bearing inner race
- 48. Idler gear
- 49. Spacer
- 50. Clip
- 51. D-ring
- 52. Transfer shaft cover
- 53. Snap ring
- 54. Driven gear
- 55. Snap ring
- 56. Outer race
- 57. Bearing inner race
- 58. Gasket

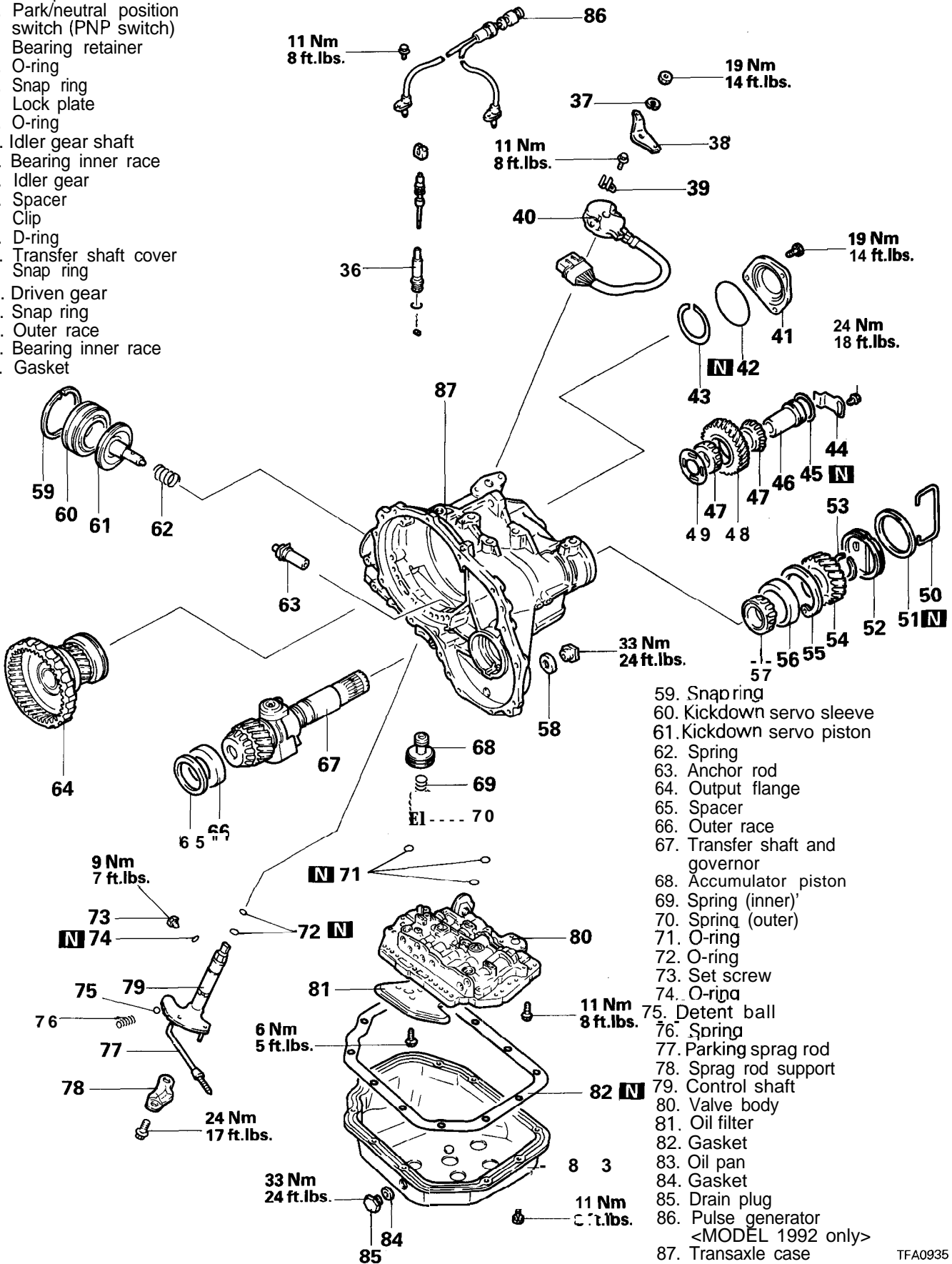

- 59. Snap ring
- 60. Kickdown servo sleeve
- 61. Kickdown servo piston
- 62. Spring
- 63. Anchor rod
- 64. Output flange
- 65. Spacer
- 66. Outer race
- 67. Transfer shaft and governor
- 68. Accumulator piston
- 69. Spring (inner)
- 70. Spring (outer)
- 71. O-ring
- 72. O-ring
- 73. Set screw
- 74. O-ring
- 75. Detent ball
- 76. Spring
- 77. Parking sprag rod
- 78. Sprag rod support
- 79. Control shaft
- 80. Valve body
- 81. Oil filter
- 82. Gasket
- 83. Oil pan
- 84. Gasket
- 85. Drain plug
- 86. Pulse generator <MODEL 1992 only>
- 87. Transaxle case

TFA0935

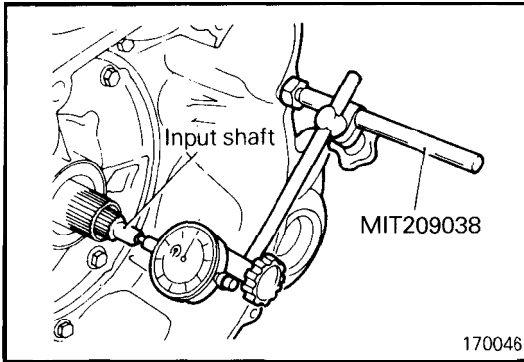

DISASSEMBLY

- (1) Prior to disassembling the transaxle, plug all openings and thoroughly clean the exterior of the assembly, preferably by steam.
- (2) Place the transaxle on the workbench with the oil pan down.
- (3) Remove the torque converter.
- (4) Measuring input shaft end play before disassembly will usually indicate when a thrust washer change is required (except when major parts are replaced). Thrust washers are located between the reaction shaft support and rear clutch retainer, and between the reaction shaft support and front clutch retainer.

Mount a dial indicator to the converter housing using the special tool, with its plunger seated against the end of the input shaft.

Move the input shaft in and out with pliers to obtain the end play reading. Be careful not to scratch the input shaft. Record the indicator reading for reference when reassembling the transaxle.

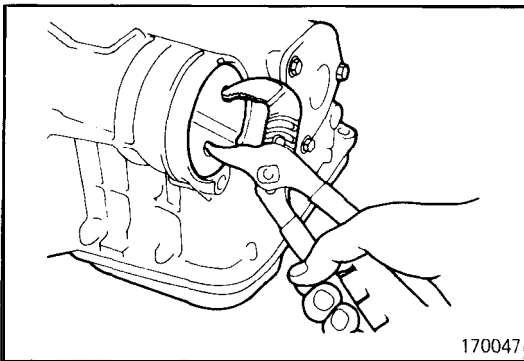

- (5) Remove the cover holder, and remove the cover.

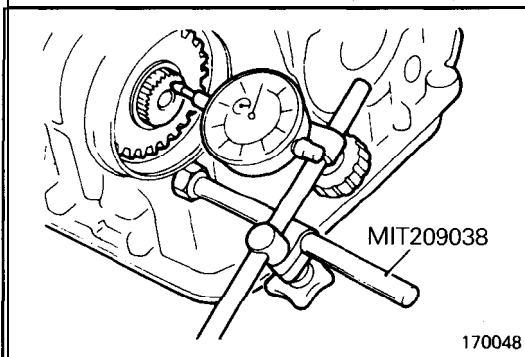

- (6) Attach the dial indicator on the transaxle case with the special tool. Measure the transfer shaft end play and record the indicator reading.

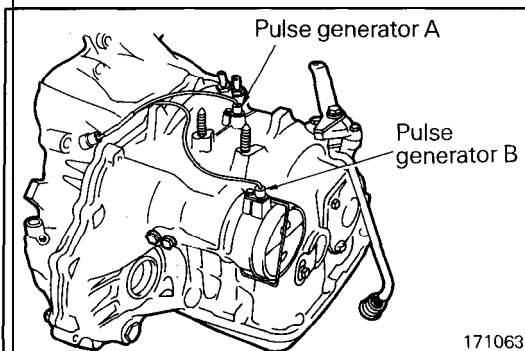

- (7) Remove the pulse generator "A" and "B".
<MODEL 1992 only>

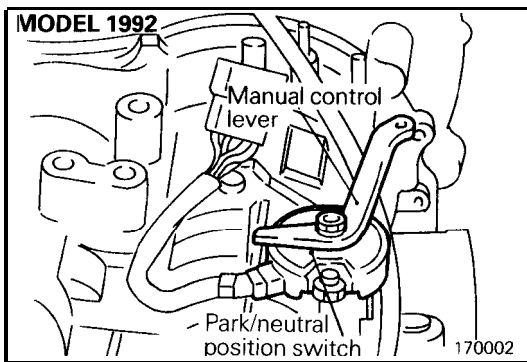

(8) Remove the manual control lever, and then remove the park/neutral position switch (PNP switch).

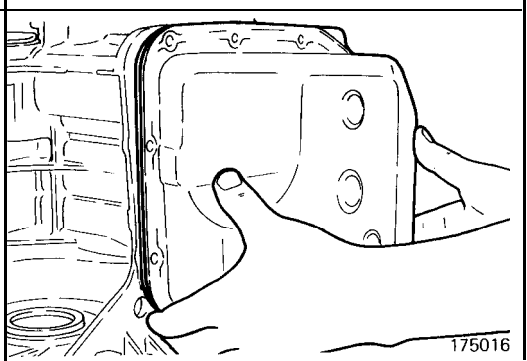
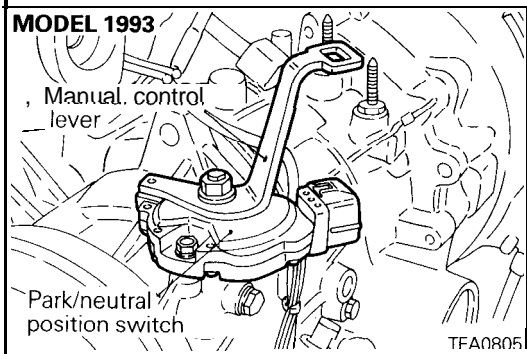

(9) Remove the oil pan and oil pan gasket.

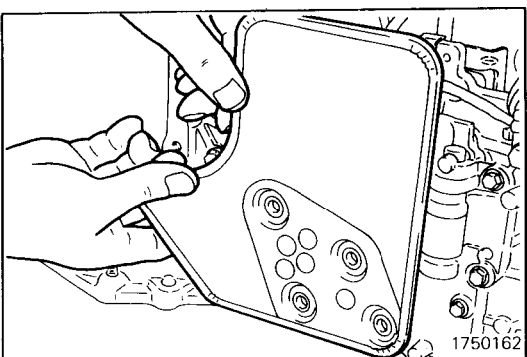

(10) Remove the oil filter.

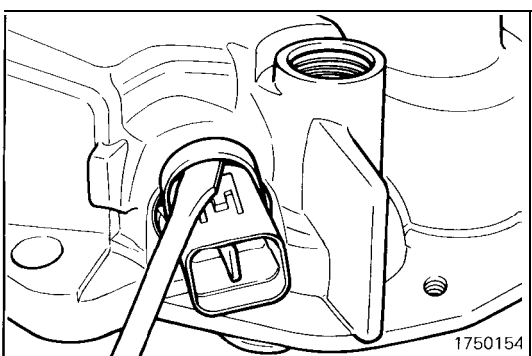

(11) Remove the clip of the solenoid valve connector.
<MODEL 1992 only>

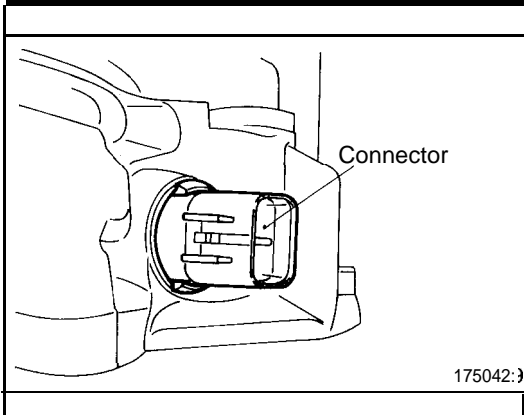

(12) Push catches and remove the solenoid valve connector.
<MODEL 1992 only>

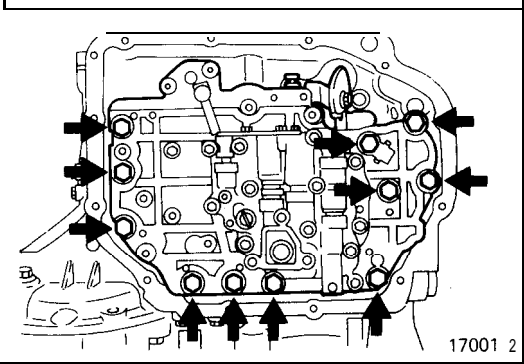

(13) Disconnect the throttle cable from the throttle cam.
(14) Remove the valve body mounting bolts indicated by arrows and remove the valve body from the transaxle case.

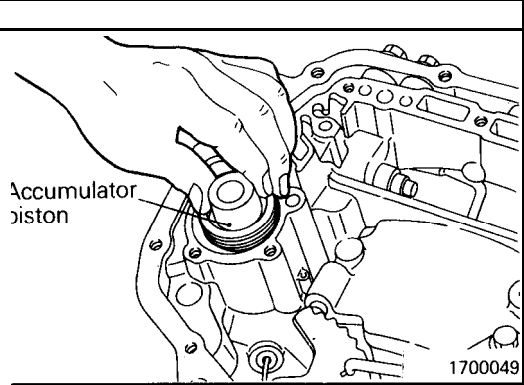

(15) Remove the two accumulator springs, then remove the accumulator piston from the transaxle case.

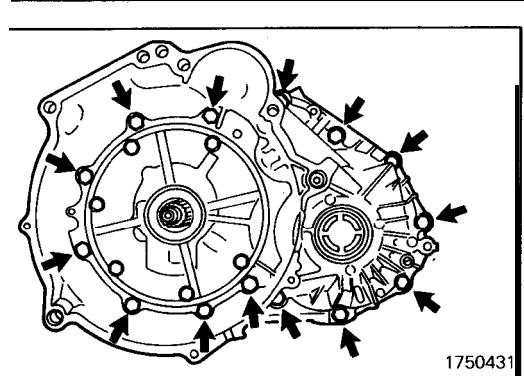

(16) Remove the 14 bolts indicated by arrows and remove the converter housing and gasket.

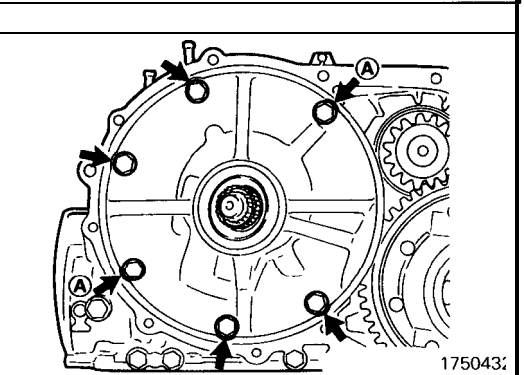

(17) Remove the six oil pump mounting bolts indicated by arrows.
(18) Screw the special tools (MD998333-01) into the bolt holes marked **A**.

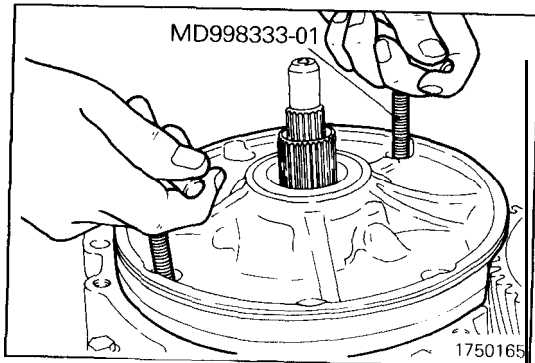

(19) Grasping the special tools, remove the oil pump. Then, remove the gasket.

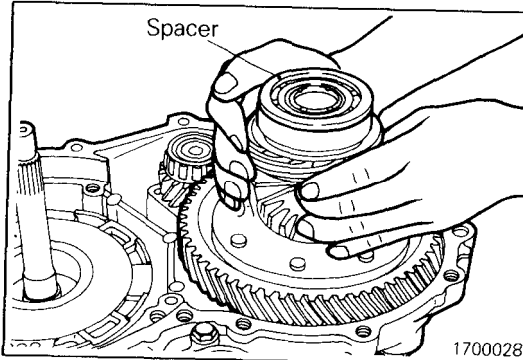

(20) Remove the spacer and differential from the transaxle case.

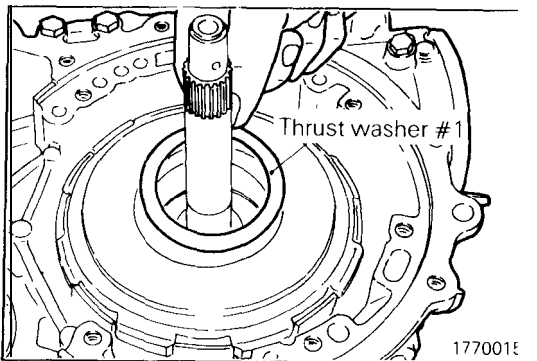

(21) Remove fiber thrust washer #1.

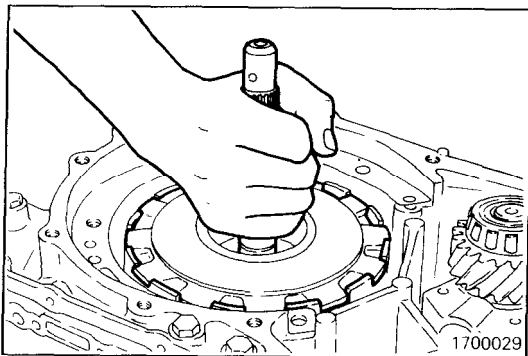

(22) Grasp and raise the input shaft to remove both the front and rear clutch assemblies together.

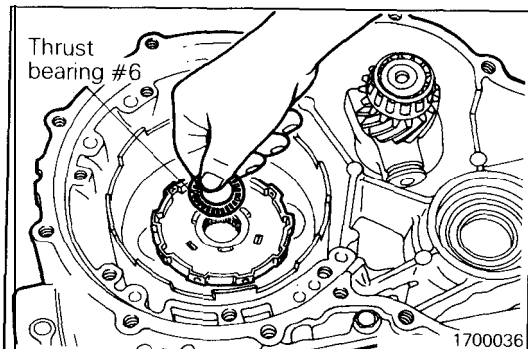

(23) Remove thrust bearing #6.

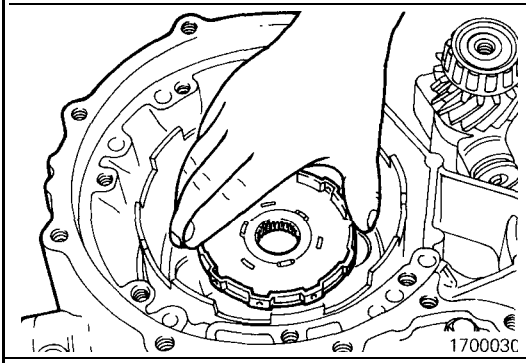

(24) Remove the clutch hub.

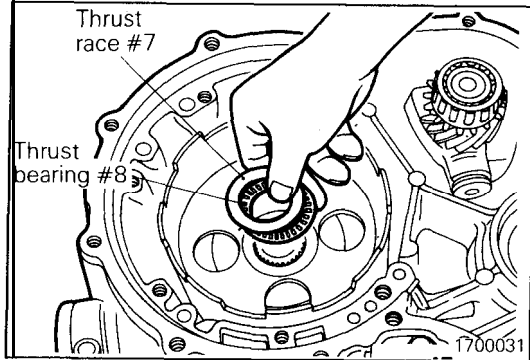

(25) Remove thrust race #7 and thrust bearing #8.

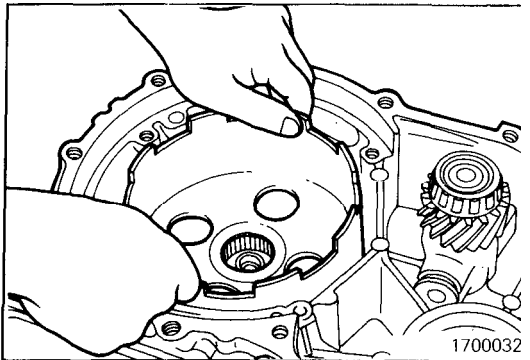

(26) Remove the kickdown drum.

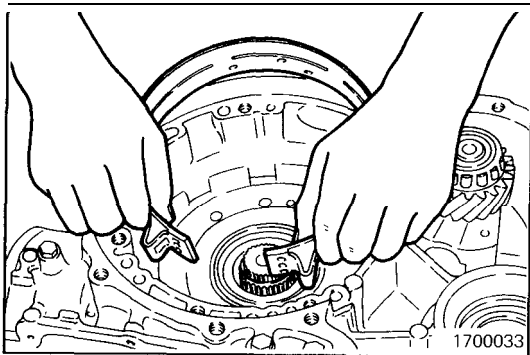

(27) Remove the kickdown band.

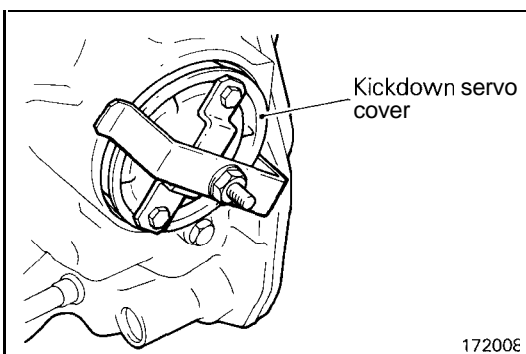

(28) Remove the snap ring.
 (29) Set the special tools as shown in the illustration, and use them to remove the kickdown servo cover.

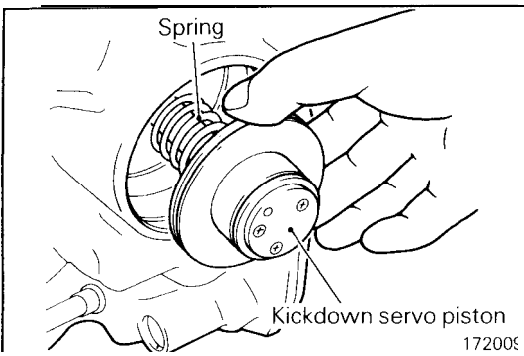

(30) Remove the kickdown servo piston and spring.

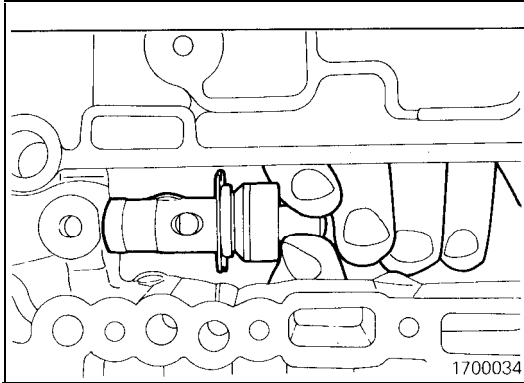

(31) Remove the anchor rod.

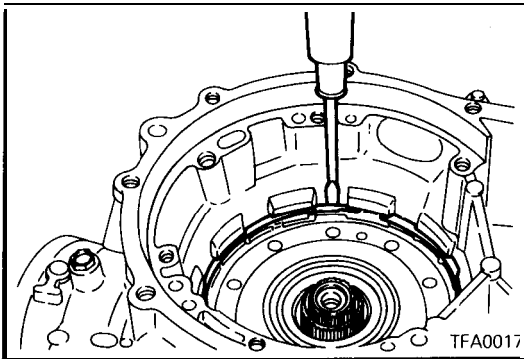

(32) Remove the snap ring.

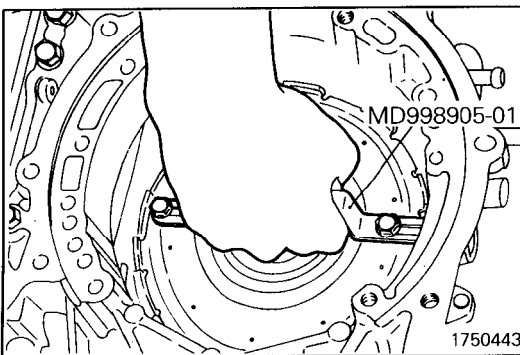

(33) Set the special tool on the center support and remove the center support from the case.

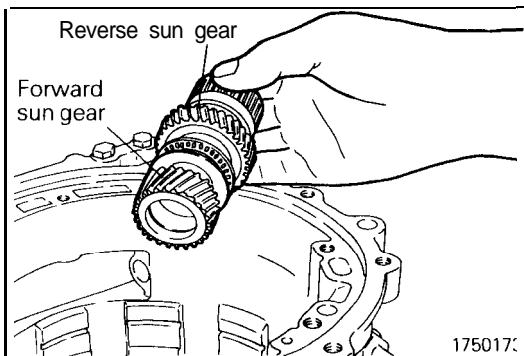

(34) Remove reverse sun gear, thrust bearing #9, thrust race #10 and forward sun gear together.

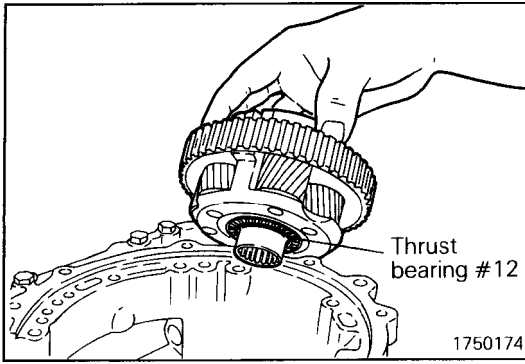

(35) Remove the planetary gear set and thrust bearing #12.

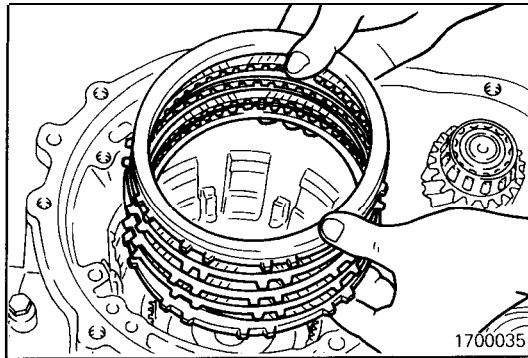

(36) Remove the wave spring, return spring, reaction plate, brake discs, and brake plates.

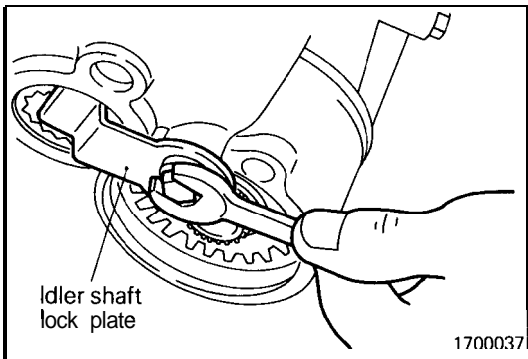

(37) Remove the idler shaft lock plate.

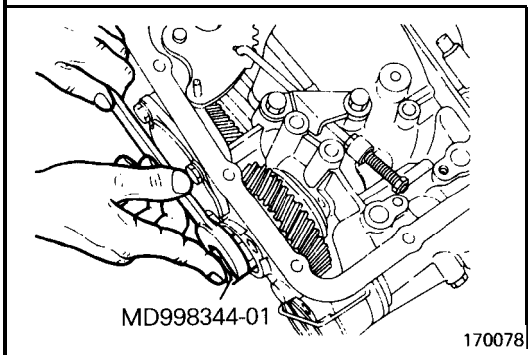

(38) Loosen the transfer idler shaft with the special tool.

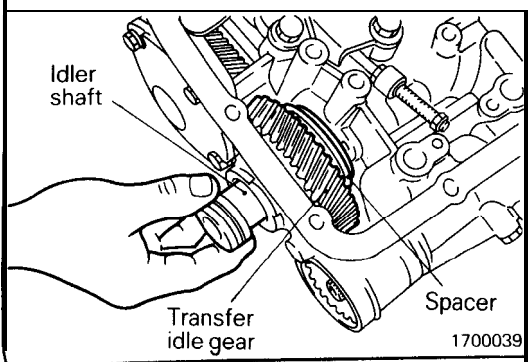

(39) Pull out the transfer idler gear shaft, and remove the transfer idler gear, the two bearing inner races, and the spacer.

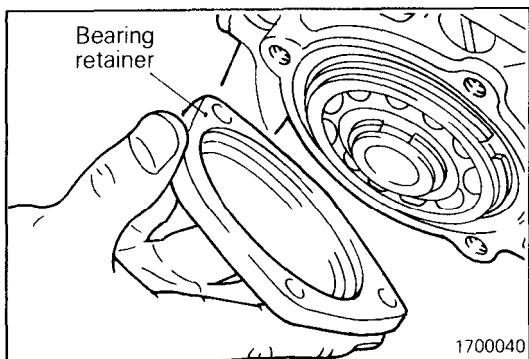

(40) Remove the bearing retainer.

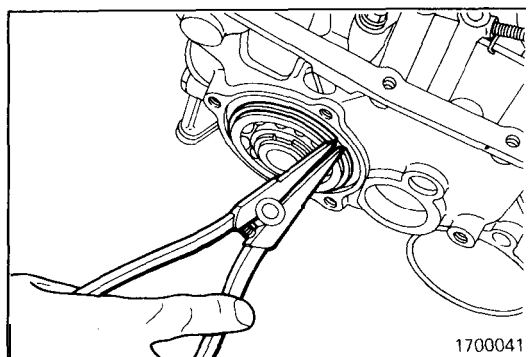

(41) Remove the snap ring from the output flange bearing.

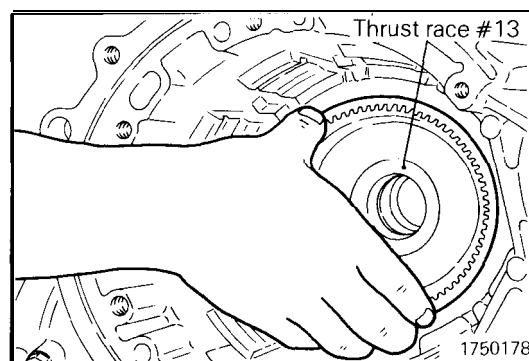

(42) Remove the output flange and thrust race #13 from the case.

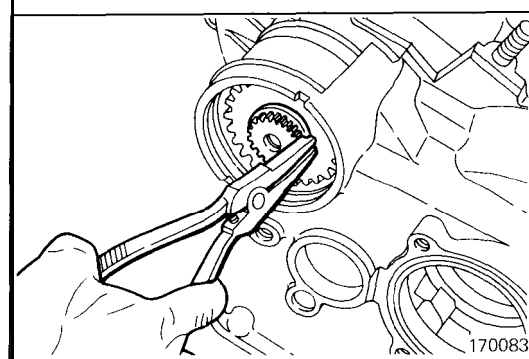

(43) Remove the snap ring from the transfer shaft.

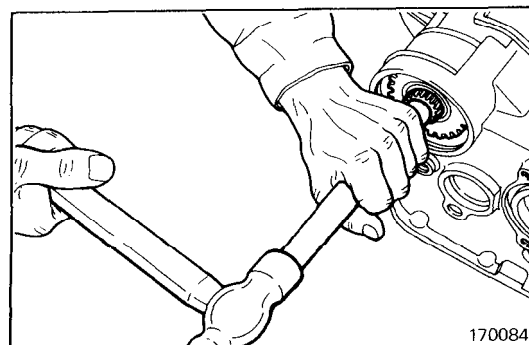

(44) Drive the transfer shaft out toward the torque converter housing to remove the shaft and the transfer driven gear.

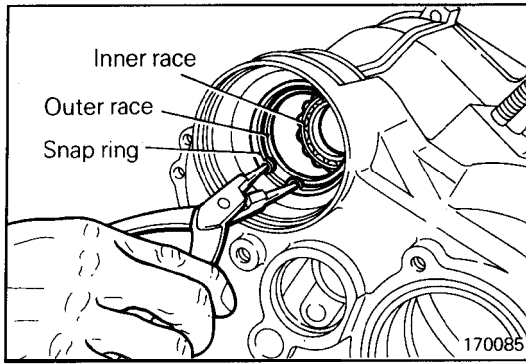

(45) Remove the snap ring, and then the tapered roller bearing inner and outer races.

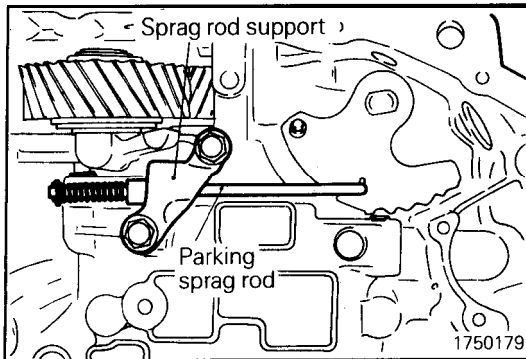

(46) Remove the sprag rod support.

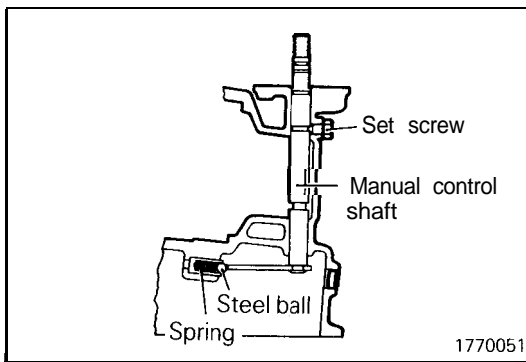

(47) Remove the set screw, and remove the manual control shaft assembly. At this time, remove also the steel ball and spring.

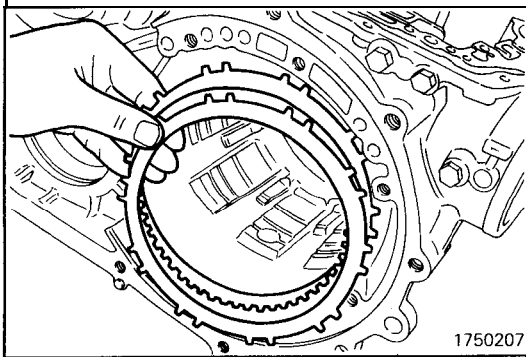

REASSEMBLY

(1) Before reassembling the transaxle, measure the end play in the low-reverse brake and select a pressure plate to obtain the specified end play. Use the following procedure.

(a) Install the brake reaction plate, brake plates and brake discs in the transaxle case.

Caution

Blow off automatic transmission fluid from the plates and discs with low-pressure compressed air.

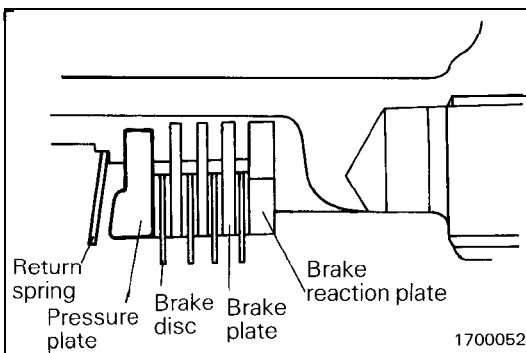

(b) Install the pressure plate and mount the return spring.

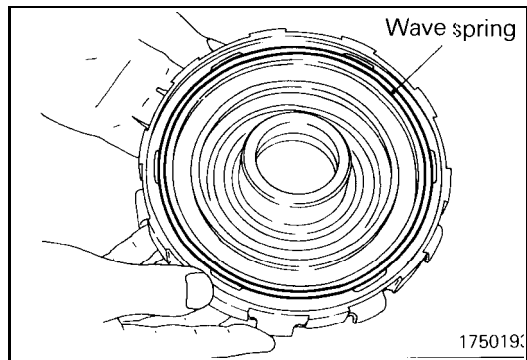

- (c) Apply petrolatum jelly to the wave spring and attach the wave spring on the low-reverse brake piston.
 (d) Install the two O-rings removed during disassembly and coat them with automatic transaxle fluid.

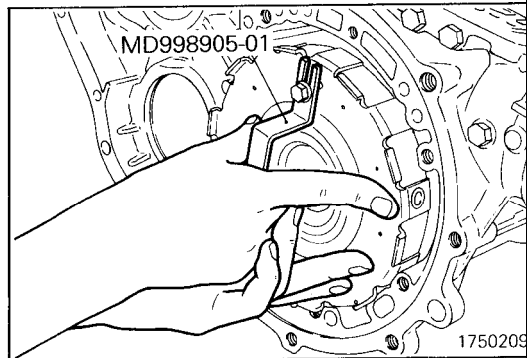

- (e) Attach the special tool to the center support and install the support in the transaxle case.

Caution

1. Install the center support, taking care that the waved spring is not out of position.
2. Install the two O-rings in alignment with the oil holes provided in the transaxle case.

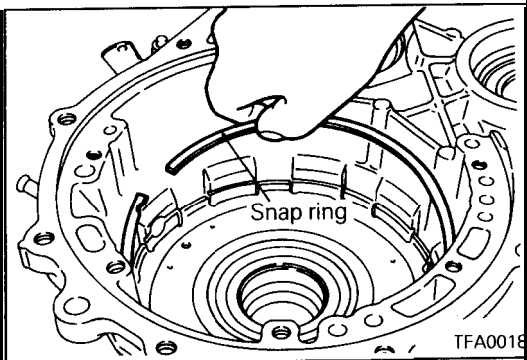

- (f) Remove the special tool
 (g) Install the snap ring.

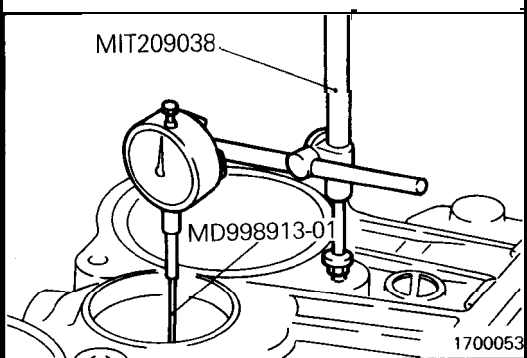

- (h) Mount the special tool and dial indicator on the rear side of the transaxle case. Make sure that the dial indicator rod (MD998913-01) is inserted into the transfer idler shaft hole, contacting the brake reaction plate at a right angle.

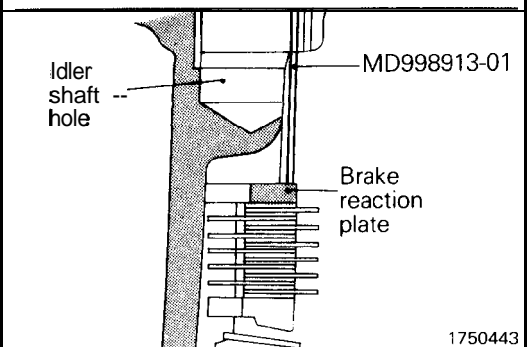

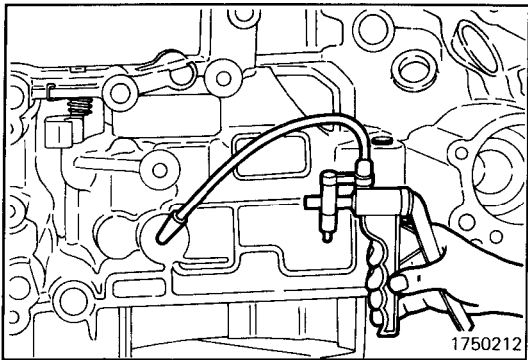

- (i) Using a hand pump, feed air through the location shown and, at the same time, read the dial indicator and select a pressure plate to obtain the specified end play.

Standard value: 0.8 – 1.0 mm (.031 – .039 in.)

- (j) After a pressure plate of the appropriate thickness has been selected, remove all the mounted parts.

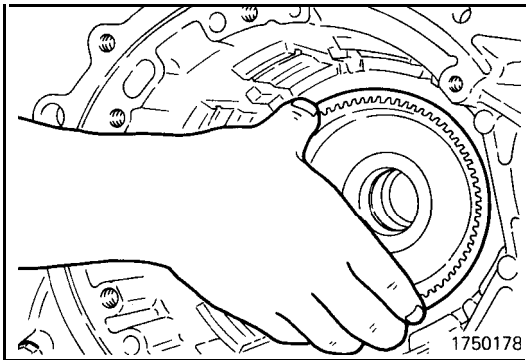

- (2) Place the transaxle case on the workbench with the oil pan mounting surface up.
 (3) Insert the output flange in position (with two ball bearings and transfer drive gear attached) from the inside of the transaxle case.

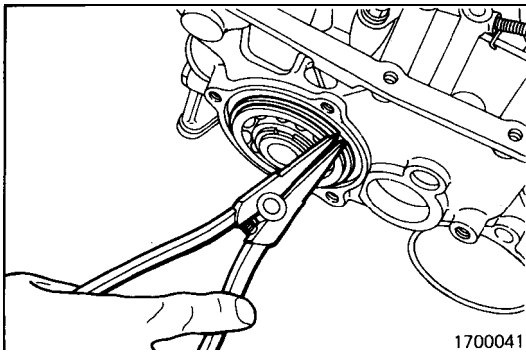

- (4) Install the snap ring in the groove of the output flange bearing.

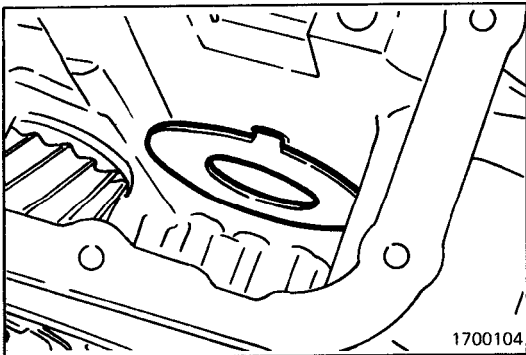

- (5) Apply petrolatum jelly to the spacer and attach the spacer to the case.

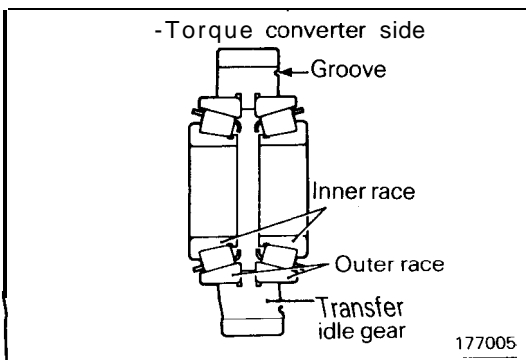

- (6) Install the bearing outer race and inner races in the transfer idle gear.

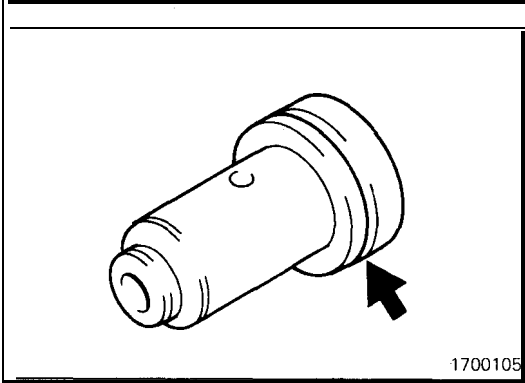

(7) Install a new O-ring in the groove of the idler shaft, and apply a very thin coat of automatic transmission fluid to the O-ring.

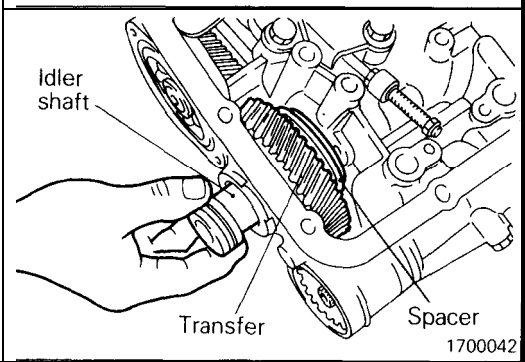

(8) Place the transfer idler gear in the case, and insert and screw the idler shaft into position.

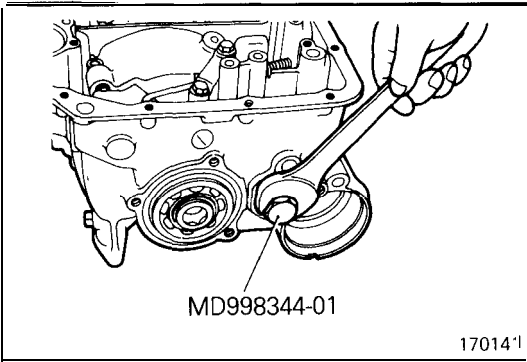

(9) Screw in and tighten the idler shaft by using the special tool.

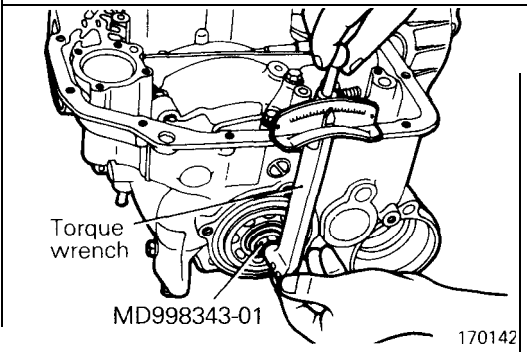

(10) Insert the special tool into the output flange and measure the preload using a low reading torque wrench. Adjust the preload to the standard value by tightening or loosening the transfer idler shaft.

Standard value: 0.8 Nm (.6 ft.lbs.)

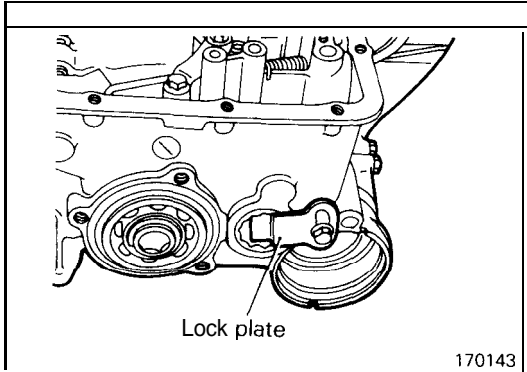

(11) After completing the preload adjustment, install the idler shaft lock plate. The clearance between the idler shaft and the lock plate should be closed in the direction that will prevent idler shaft looseness, and then tighten the lock plate bolt to specified torque.

Tightening torque: 24 Nm (18 ft.lbs.)

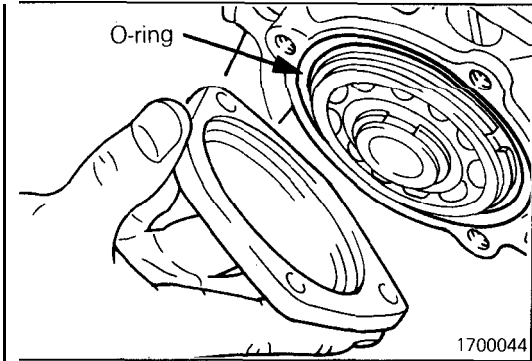

(12) Install a new O-ring in the groove of the transaxle case, and then install the bearing retainer.

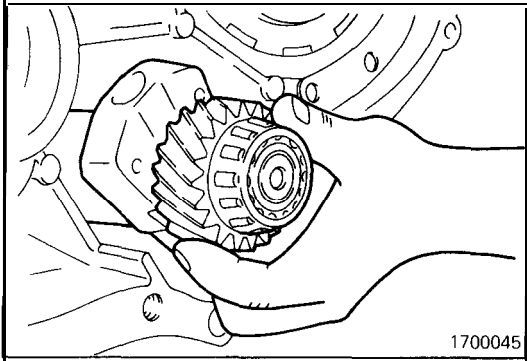

(13) Insert the transfer shaft in the case.

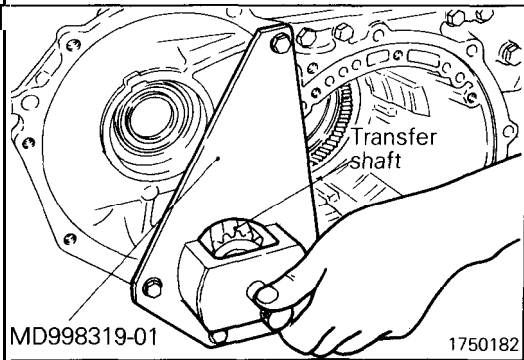

(14) Mount the special tool on the transmission case to support the transfer shaft.

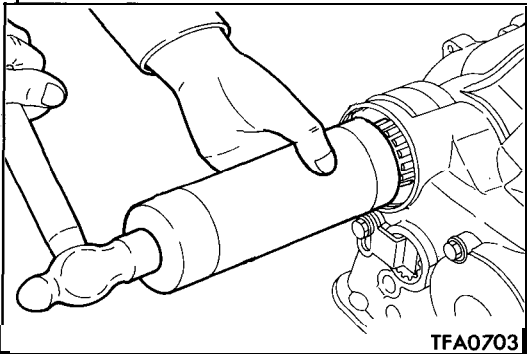

(15) Use the special tool to install the bearing inner race on the transfer shaft.

(16) Install the tapered roller bearing outer race, and then the snap ring.

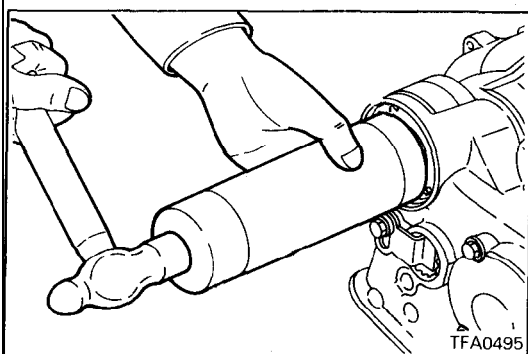

(17) Use the special tool to install the transfer driven gear on the transfer shaft.

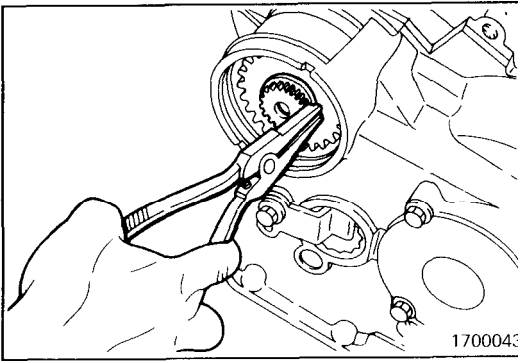

(18) Install the snap ring on the end of the transfer shaft.

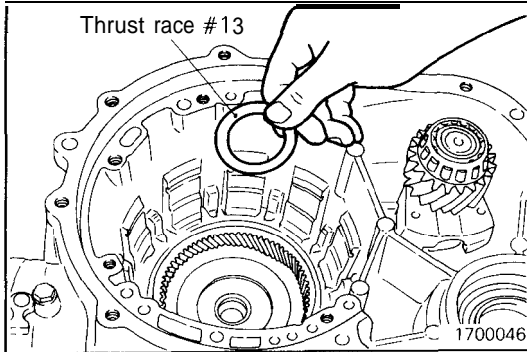

(19) Coat thrust race #13 with petrolatum jelly and attach it to the output flange.

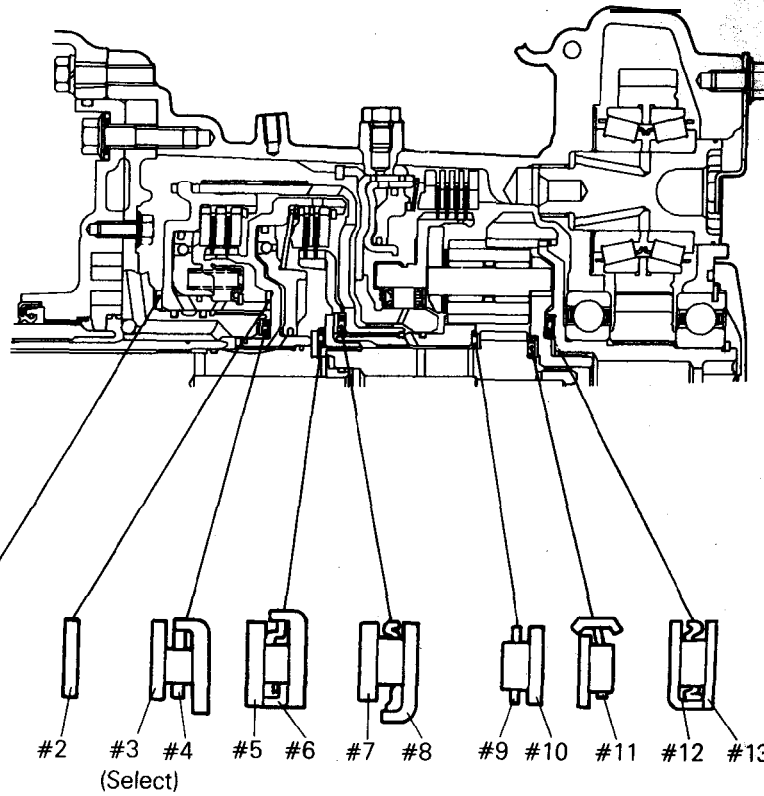

1700047

IDENTIFICATION OF THRUST BEARINGS, THRUST RACES, AND THRUST WASHERS

mm (in.)

O D.	I.D.	Thickness	Part No.	Identification marking	O.D.	I.D.	Thickness	Part No.	Identification marking
70 (2.756)	55.7 (2.193)	1.4 (.055)		#1	48.1 (1.906)	34.4 (1.354)	—	MD707271	#4
70 (2.756)	55.7 (2.193)	1.8 (.071)		#2	40 (1.575)	21 (.827)	2.4 (.094)	MD722552	#5
70 (2.756)	55.7 (2.193)	2.2 (.087)		#3	42.6 (1.677)	28 (1.102)	—	MD720753	#6
70 (2.756)	55.7 (2.193)	2.6 (.102)		#4	54 (2.126)	38.7 (1.524)	1.6 (.063)	MD704936	#7
70 (2.756)	55.7 (2.193)	1.8 (.071)	MD707290	#2	52 (2.047)	36.4 (1.433)	—	MD720010	#8
48.9 (1.925)	37 (1.457)	1.0 (.039)	MD997854 (incl.*1)	#3	41 (1.614)	28 (1.102)	—	MD728763	#9
48.9 (1.925)	37 (1.457)	1.2 (.047)	MD997847 (incl.*1)		39 (1.535)	28 (1.102)	1.2 (.047)	MD728764	#10
48.9 (1.925)	37 (1.457)	1.4 (.055)	MD997848 (incl.*2)		38 (1.496)	22.2 (.874)	—	MD727787	#11
48.9 (1.925)	37 (1.457)	1.6 (.063)	MD997849 (incl.*2)		52 (2.047)	36.4 (1.433)	—	MD720010	#12
48.9 (1.925)	37 (1.457)	1.8 (.071)	MD997850 (incl.*3)		54 (2.126)	38.7 (1.524)	0.8 (.031)	MD704935	#13
48.9 (1.925)	37 (1.457)	2.0 (.079)	MD997851 (incl.*3)						
48.9 (1.925)	37 (1.457)	2.2 (.087)	MD997852 (incl.*4)						
48.9 (1.925)	37 (1.457)	2.4 (.094)	MD997853 (incl.*4)						

TSB Revision

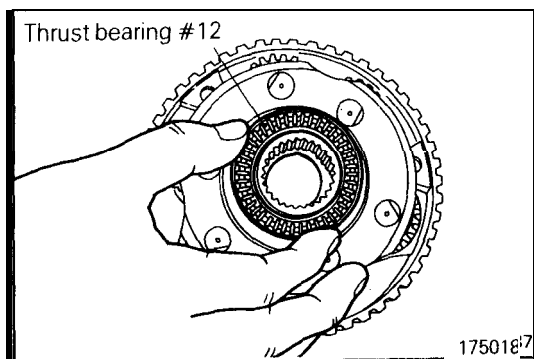

(20) Apply petrolatum jelly to thrust bearing #12 and secure the bearing on the planetary carrier.

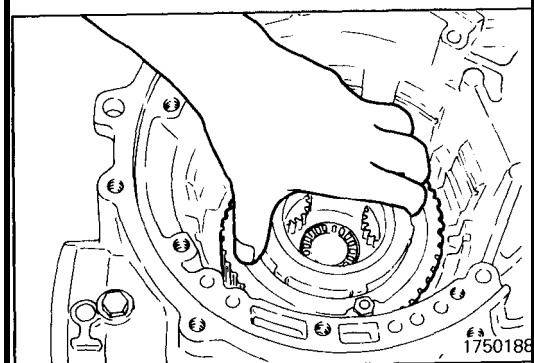

(21) Mount the planetary carrier on the case.

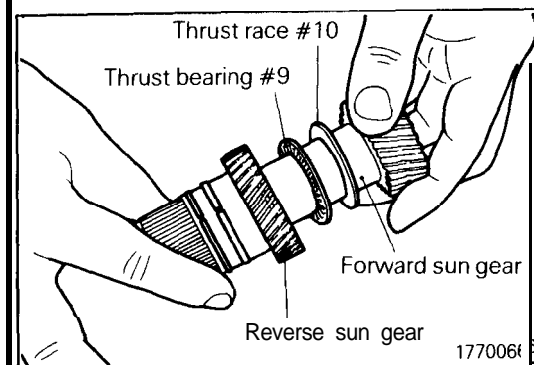

(22) Attach thrust race #10 and thrust bearing #9 to the forward sun gear. Then, assemble the reverse sun gear.

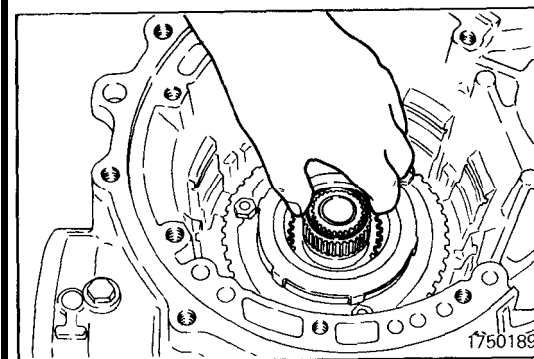

(23) Install the sun gear assembly assembled in step (22) in the planetary carrier.

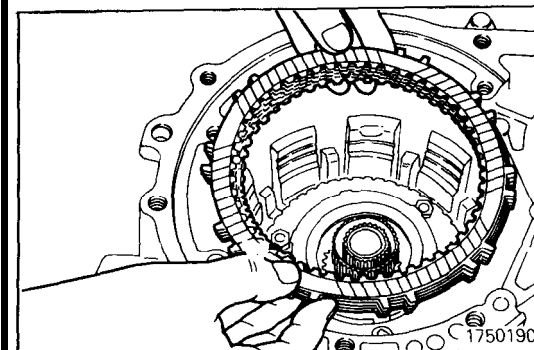

(24) Put the brake disc and brake plate in position.

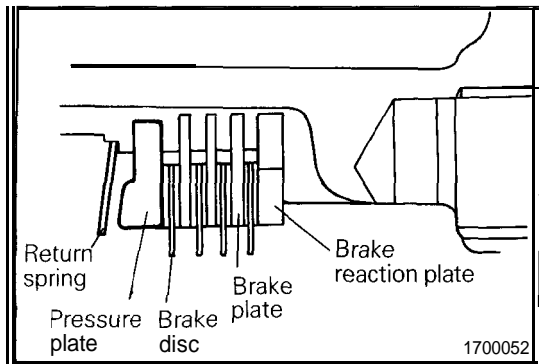

(25) Install the brake pressure plate which was selected in Step (1).

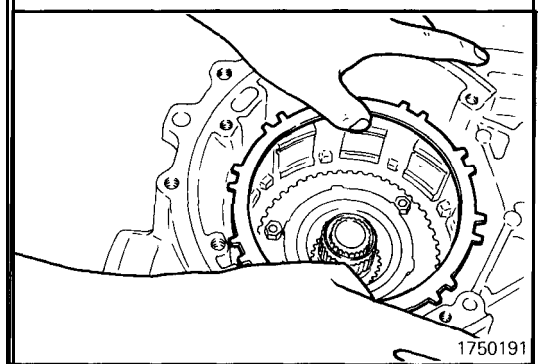

(26) Install the return spring.

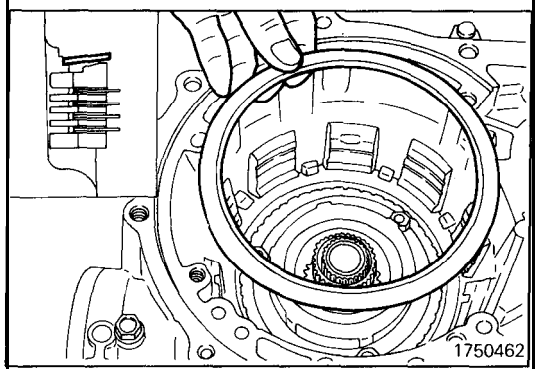

(27) Apply petrolatum jelly to the wave spring and attach the wave spring to the center support.

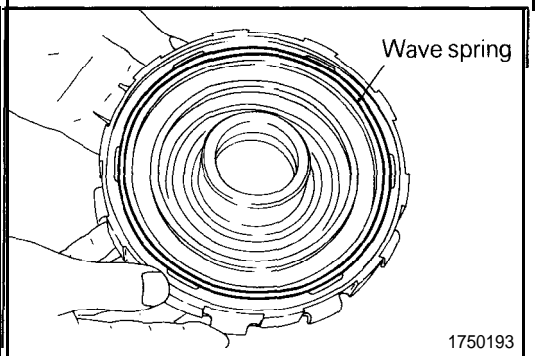

(28) Install the two new O-rings on the hydraulic pressure holes of the center support. Coat the O-rings with automatic transmission fluid.

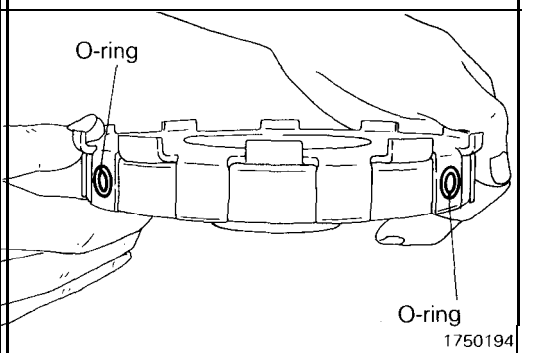

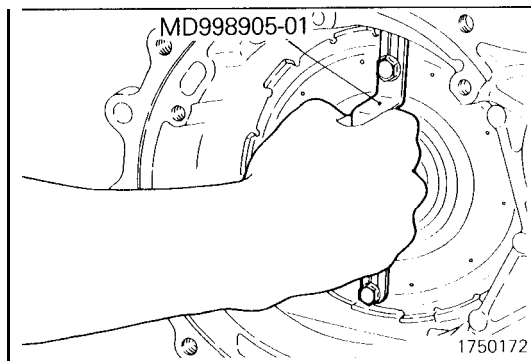

(29) Attach the special tool to the center support and install the support in the transaxle case.

Caution

1. Install the center support, taking care that the waved spring is not out of position.
2. Install the two O-rings in alignment with the oil holes provided in the transmission case.

(30) Remove the special tool from center support.

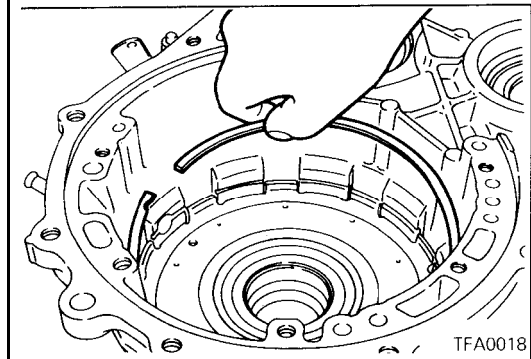

(31) Install the snap ring for the center support.

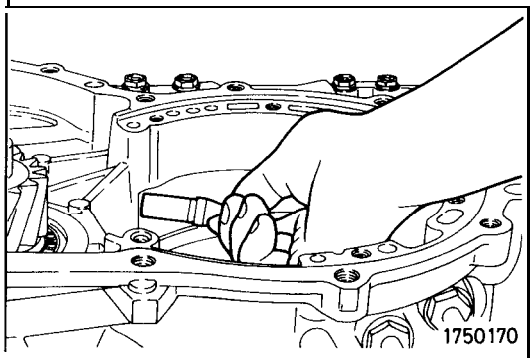

(32) Install the anchor rod, in the transaxle case.

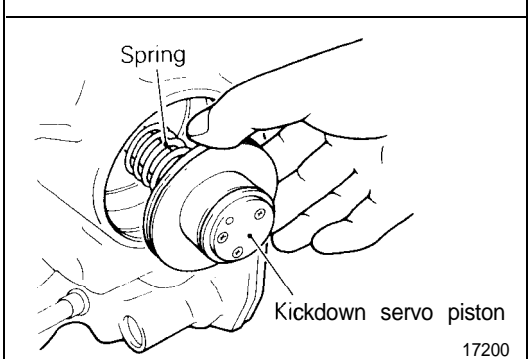

(33) Install new seal rings in the grooves of the kickdown servo piston and coat the rings with automatic transaxle fluid.
 (34) Insert the kickdown servo spring and piston in the transaxle case.

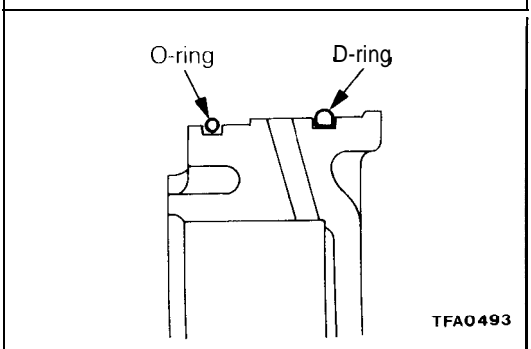

(35) Install a new O-ring and D-ring on the kickdown servo sleeve, and apply a very thin coat of automatic transaxle fluid to the rings.

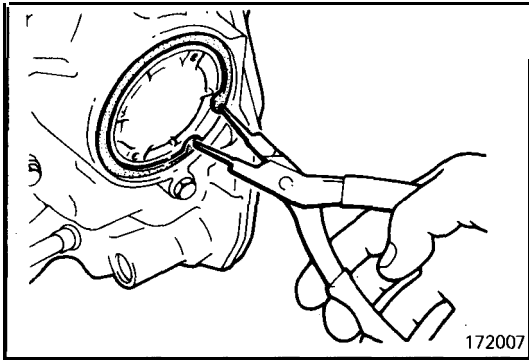

(36) Insert the kickdown servo sleeve in the transaxle case and install the snap ring.

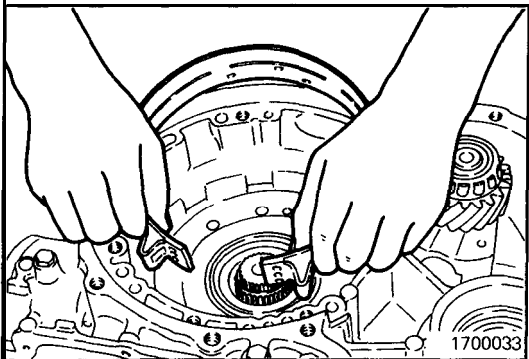

(37) Install the kickdown band; attach the ends of the band to the ends of the anchor rod and servo piston rod.

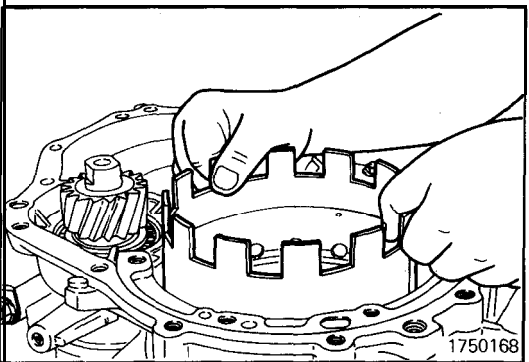

(38) When putting the kickdown drum in the kickdown band, engage the splines of the kickdown drum with those of the reverse sun gear.

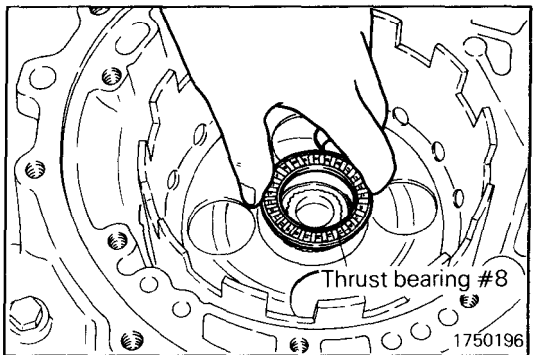

(39) Apply petrolatum jelly to thrust bearing #8 and attach the thrust bearing to the kickdown drum.

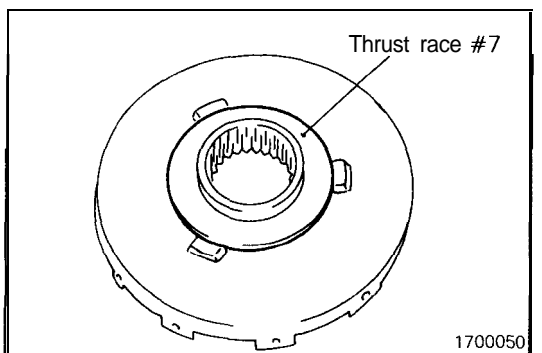

(40) Apply petrolatum jelly to thrust race #7 and attach the thrust race to the rear clutch hub.

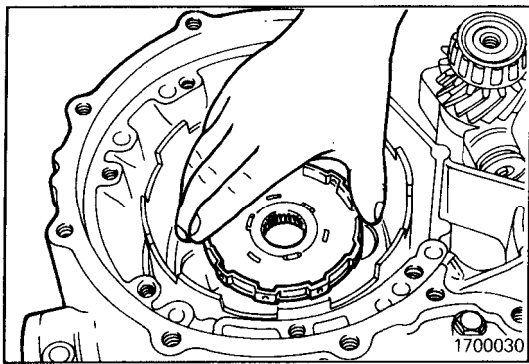

(41) Install the rear clutch hub, engaging it with the forward sun gear splines.

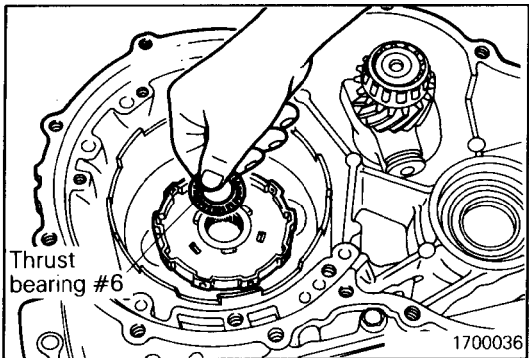

(42) Apply petrolatum jelly to thrust bearing #6 and attach it to the clutch hub.

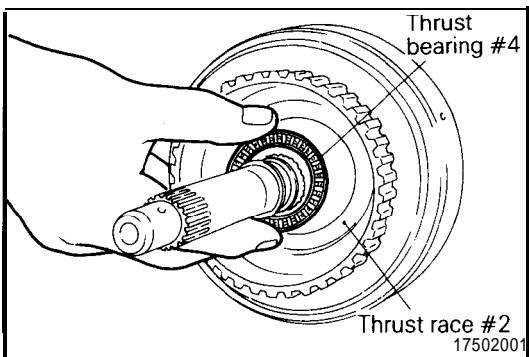

(43) Apply petrolatum jelly to thrust washer #2 and thrust bearing #4 and attach the washer and bearing to the rear clutch assembly.

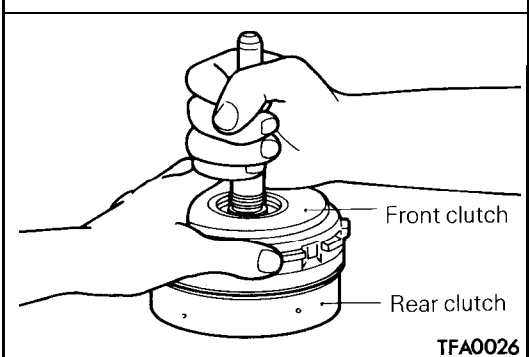

(44) Mate the rear clutch assembly with the front clutch assembly.

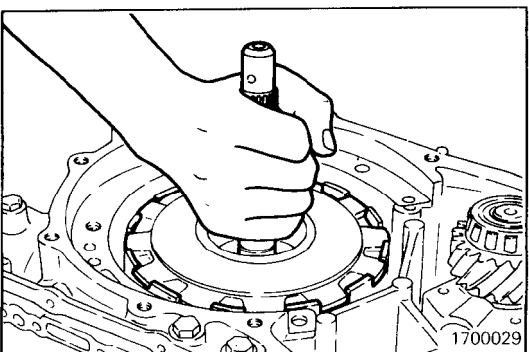

(45) Install the clutch assembly.

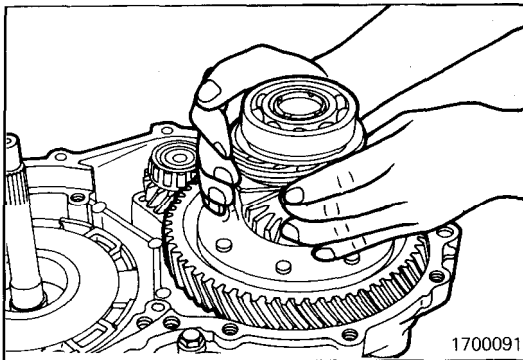

(46) Install the differential.

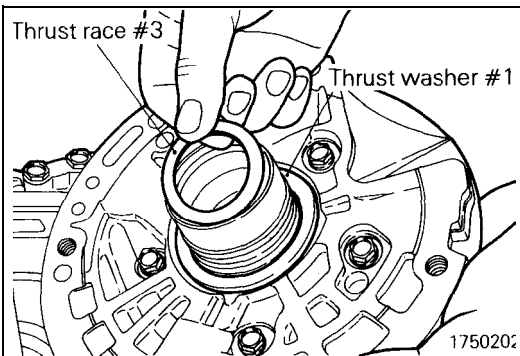

(47) Attach thrust race #3 and thrust washer #1 to the rear end face of the oil pump with petrolatum jelly.

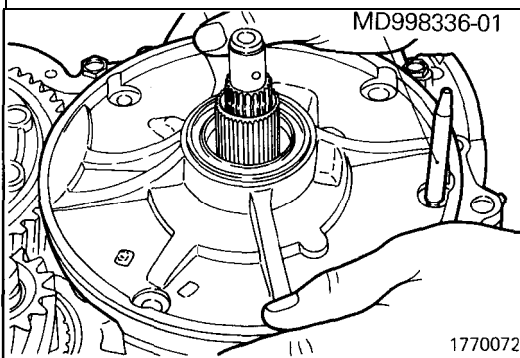

(48) Attach the special tool to the transaxle case. Using the tool as a guide, first install a new oil pump gasket and then the oil pump in the case.

(49) Remove the special tool.

(50) Tighten the oil pump bolts to the specified torque.

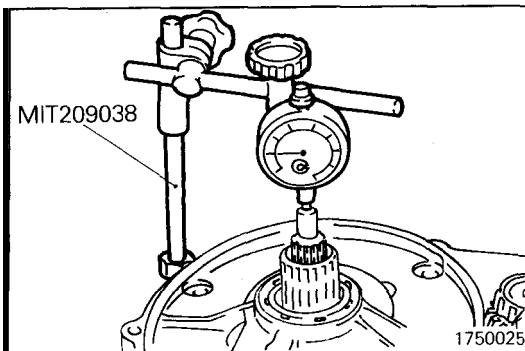

(51) Measure the end play of the input shaft. If the measurement is out of specification, replace thrust race #3 and thrust washer #1 to meet the specification.

Standard value: 0.3 – 1.0 mm (.012 – .039 in.)

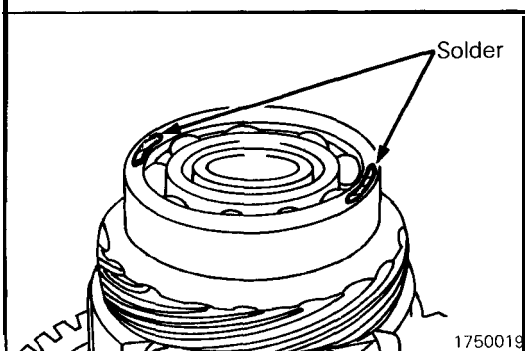

(52) Place approx. 10 mm (.394 in.) long and 2.5 mm (.10 in.) dia. pieces of solder at the locations shown on the differential assembly.

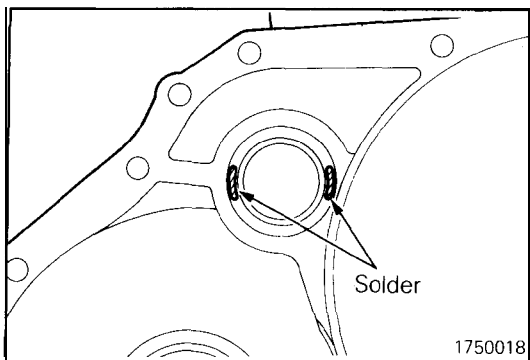

1750018

- (53) Place approx. 10 mm (.394 in.) long and 2 mm (.08 in.) dia. pieces of solder at the illustrated locations on the converter housing. Place the outer race of transfer shaft front bearing in position.

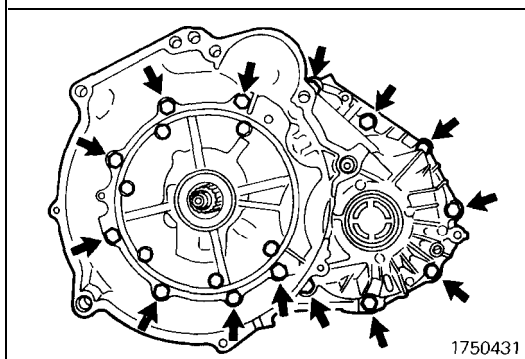

1750431

- (54) Install the converter housing directly to the transaxle case without installing the rubber coated metal gasket.
 (55) Tighten the bolts to the specified torque.
 (56) Loosen the bolts, remove the converter housing and remove the flattened solder pieces.

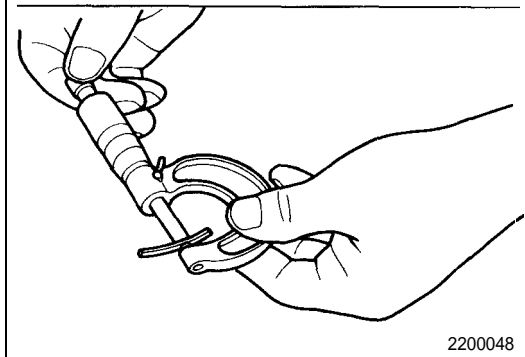

2200048

- (57) Measure the thickness of the flattened solder using a micrometer. Add the measured solder thickness (T) to the value 0.38 mm (.015 in.), which corresponds to the gasket thickness. Then add to or subtract from that sum a value corresponding to the specified preload or end play range. The result obtained is the thickness of the spacer to be selected.

For the transfer shaft, select a spacer whose thickness falls within the range determined by the formulas below:

$$[T + 0.38 \text{ mm (.015 in.)} + 0.1 \text{ mm (.004 in.)}] \text{ to } [T + 0.38 \text{ mm (.015 in.)} + 0.15 \text{ mm (.006 in.)}]$$

For the differential case spacer, determine the thickness using the following formulas:

$$[T + 0.38 \text{ mm (.015 in.)} - 0.15 \text{ mm (.006 in.)}] \text{ to } [T + 0.38 \text{ mm (.015 in.)} - 0 \text{ mm (0 in.)}]$$

Transfer shaft preload:

$$0.1 - 0.15 \text{ mm (.004 - .006 in.)}$$

Differential case end play:

$$0 - 0.15 \text{ mm (0 - .006 in.)}$$

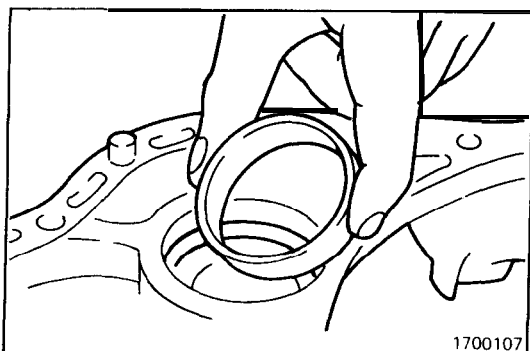

1700107

- (58) Place the spacer for the transfer shaft which was selected in Step (57) in the transfer shaft bearing hole in the converter housing, and insert the bearing outer race in the case.

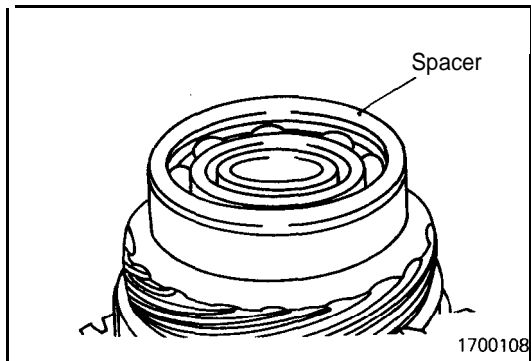

- (59) Place the spacer for the differential case which was selected in Step (57) on the bearing outer race.

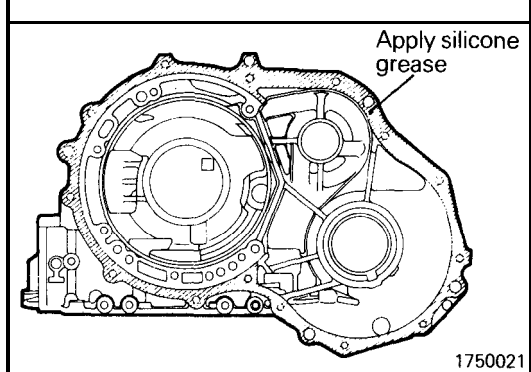

- (60) Coat the gasket surface of the transaxle case with 'silicone grease.
 (61) Install a new gasket on the transaxle case.

Caution

Do not reuse the gasket which was previously removed.

- (62) Install the converter housing with the 14 bolts. Tighten the bolts to the specified torque.

Specified torque: 21 Nm (16 ft.lbs.)

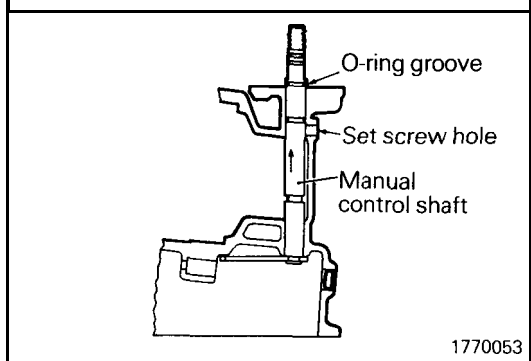

- (63) Install the parking sprag rod to the manual control shaft. Then, insert the shaft in the transaxle as shown in the illustration. In doing this work, do not install O-ring in the O-ring groove.

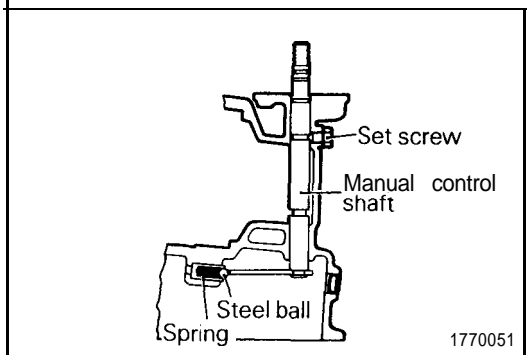

- (64) After installing a new O-ring on the manual control shaft assembly, draw the shaft back into the case, then install the set screw and gasket. Also install the detent steel ball, seat and spring at the same time.

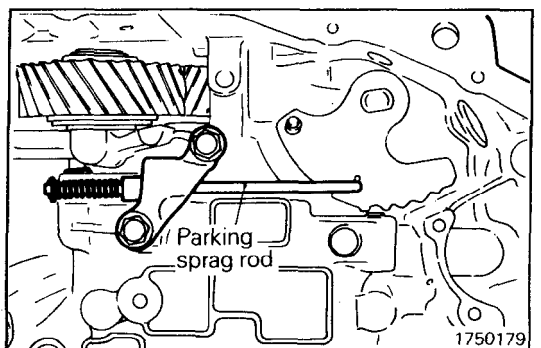

- (65) Place the case with the oil pan mounting surface up.
 (66) Install the sprag rod support and tighten the two bolts to the specified torque.

Specified torque: 24 Nm (18 ft.lbs.)

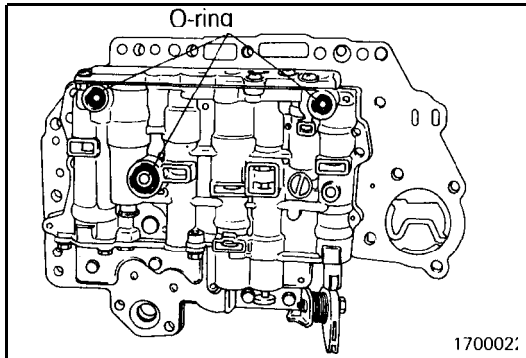

(67) Install the O-rings in the O-ring grooves at three locations on the valve body.

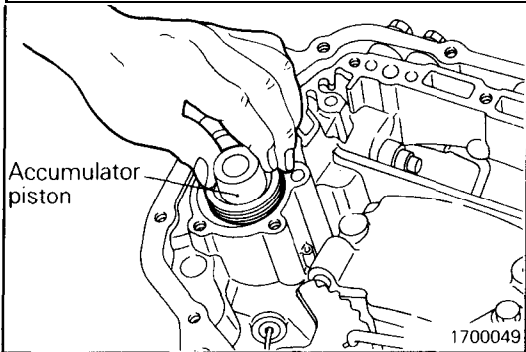

(68) Install new seal rings in the groove of the accumulator piston and coat the rings with automatic transmission fluid.
 (69) Install the accumulator piston in the transmission case and install the two springs.

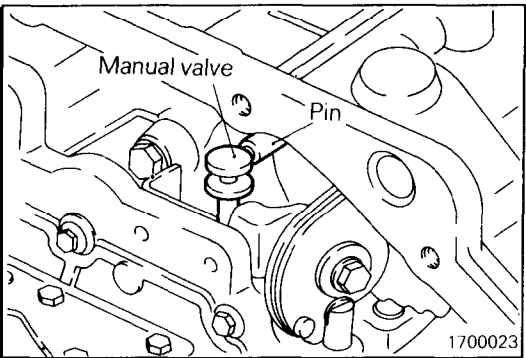

(70) Install the valve body in the transaxle case while fitting the detent plate pin in the gap between the lands of the manual valve.

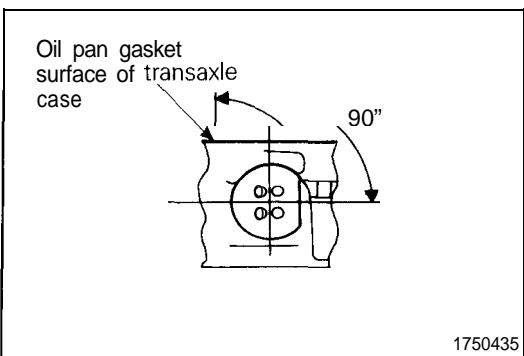

(71) Replace the O-ring of the solenoid valve connector with a new one. <MODEL 1992 only>
 (72) Insert the solenoid valve connector into the case. Be sure that the notched part of the connector faces as shown in the illustration. <MODEL 1992 only>

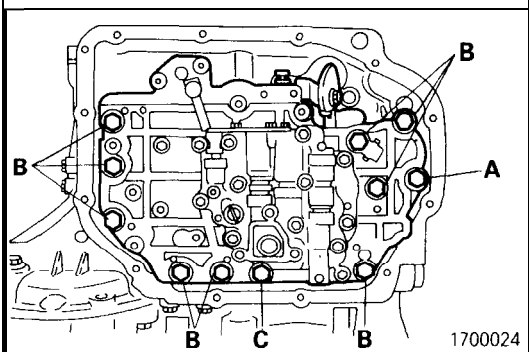

(73) Tighten the valve body mounting bolts (10 pieces) to the specified torque.

- A bolt 18 mm (.709 in.) long
- B bolt 25 mm (.984 in.) long
- C bolt 40 mm (1.575 in.) long

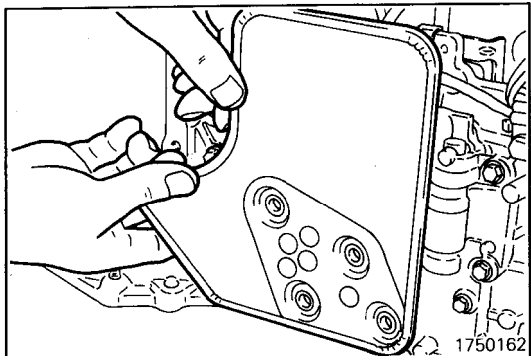

(74) Install the oil filter and tighten the four oil filter mounting bolts to the specified torque.

Specified torque: 11 Nm (8 ft.lbs.)

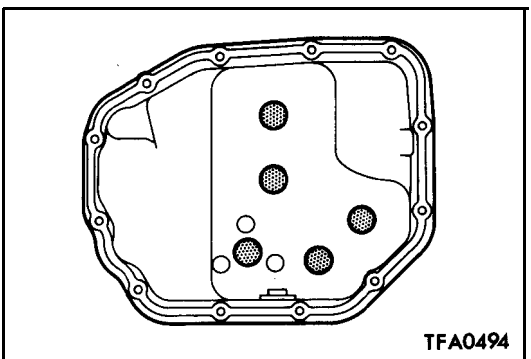

(75) Install the magnet to one of the recesses provided inside the oil pan.

Be sure to remove metal particles from the magnets and clean the inside of the oil pan beforehand.

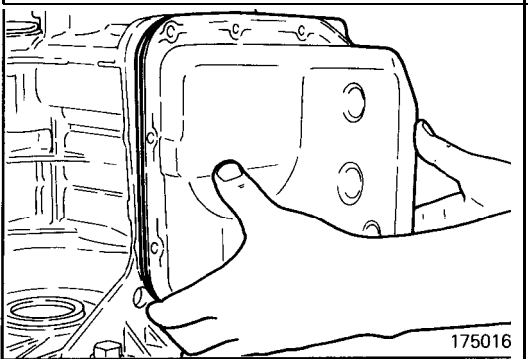

(76) Clean the gasket surfaces of both the transaxle case and oil pan. Using a new oil pan gasket, install the oil pan by tightening the 12 bolts to the specified torque.

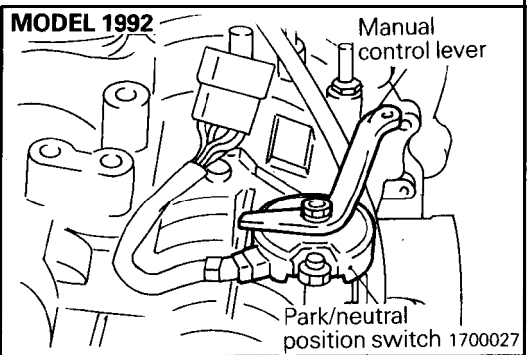

(77) Install the park/neutral position switch (PNP switch) and manual control lever, and tighten the manual control lever nut to the specified torque.

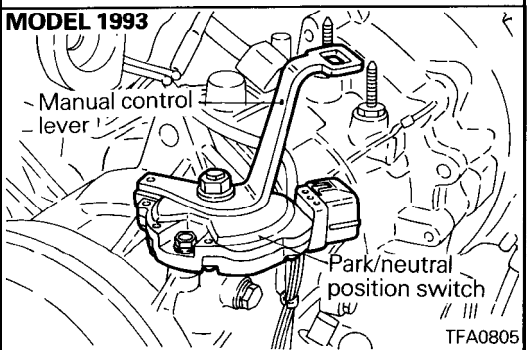

MODEL 1992

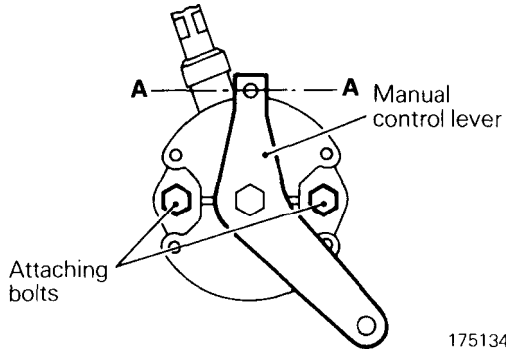
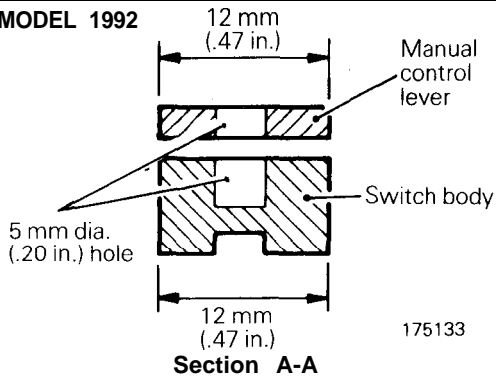

MODEL 1993

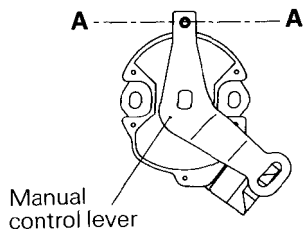
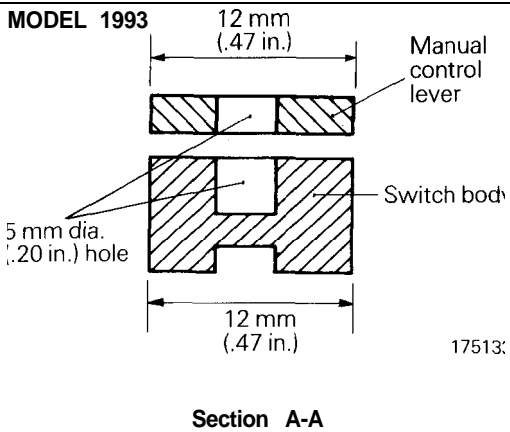

(78) Adjust the park/neutral position switch by the following procedure:

- (a) Place the manual control lever in the "N" (neutral) position.
- (b) Turn the park/neutral position switch body until the 12 mm (.47 in.) wide end of the manual control lever aligns with the switch body flange [12 mm (.47 in.) wide portion]. Alternatively turn the switch body until the 5 mm (.20 in.) hole in manual control lever aligns with the 5 mm (.20 in.) hole in the switch body.
- (c) Tighten the attaching bolts to specified torque taking care that switch body is not displaced.

Tightening torque: 11 Nm (8 ft.lbs.)

MODEL 1992

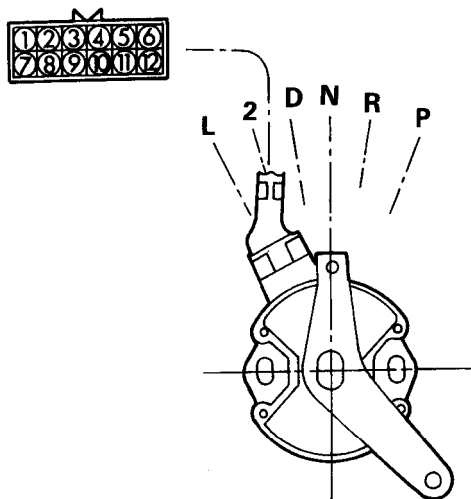

1750149

MODEL 1993

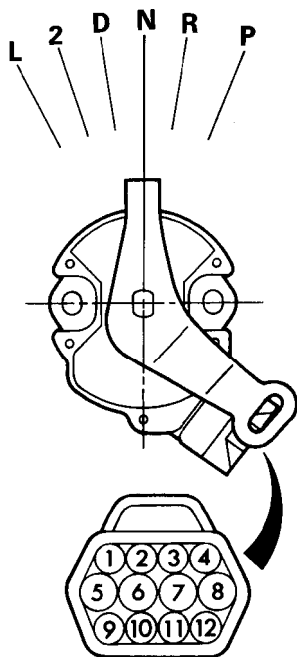

TFA079:3

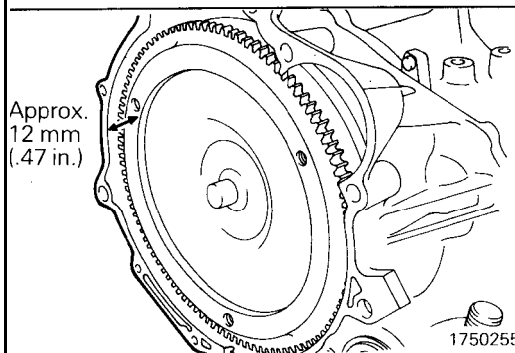

1750255

(79) Check the continuity between terminals with the manual control lever at each position. The continuity between terminals should be as shown in the table below.

Internal Connection in the Inhibitor Switch – MODEL 1992

Terminal No.	P	R	N	D	2	L	Connected circuits
1					○		
2			○				
3	○						
4	○	○	○	○	○	○	Ignition switch "ON" terminal
5						○	
6				○			
7		○					
8	○		○				Ignition switch "ST" terminal
9	○		○				Starter motor "S" terminal
10		○					Ignition switch "ON" terminal
11		○					Backup lamp

Internal Connection in the Inhibitor Switch – MODEL 1993

Terminal No.	P	R	N	D	2	L	Connected circuits
1	○						
2			○				
3					○		
4		○	○	○	○	○	Ignition switch "ON" terminal
5	○		○				Ignition switch "ST" terminal
6		○					Backup lamp
7							Ignition switch "ON" terminal
8	○		○				Starter motor "S" terminal
9		○					
10		○					
11						○	

Lack of continuity indicates a poorly adjusted switch or faulty switch. Readjust the switch. If still without continuity, replace the switch.

(80) Measure the distance between the ring gear end and the converter housing end. The torque converter has been properly installed if the measurement is approx. 12 mm (.47 in.).

OIL PUMP

DISASSEMBLY AND REASSEMBLY

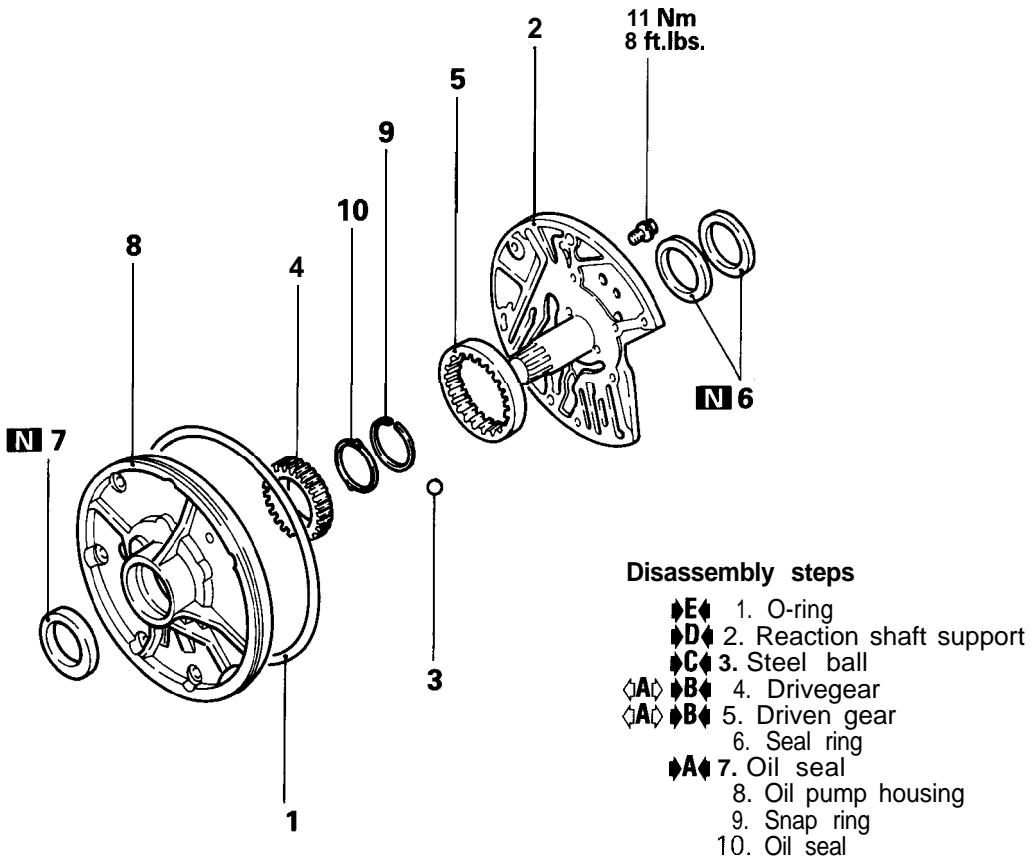

1750261

DISASSEMBLY SERVICE POINT

◊A◊ **DRIVE GEAR / DRIVEN GEAR REMOVAL**

(1) Make reassembly alignment marks on the drive and driven gears.

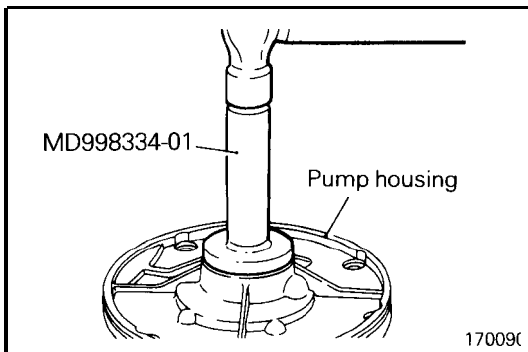

REASSEMBLY SERVICE POINTS

▶A▶ **OIL SEAL INSTALLATION**

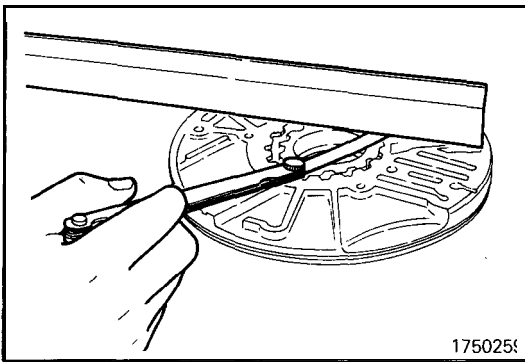

◆B◆ DRIVEN GEAR / DRIVE GEAR SIDE CLEARANCE MEASUREMENT

Standard value:

0.03 – 0.05 mm (.001 – .002 in.)

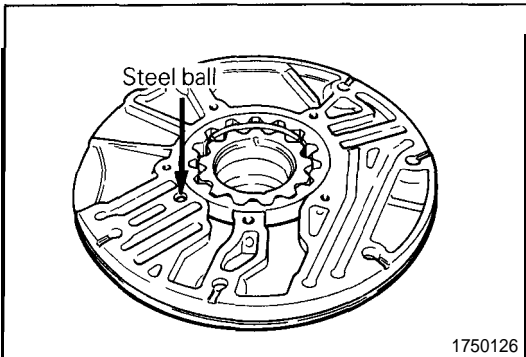

◆C◆ STEEL BALL LOCATION

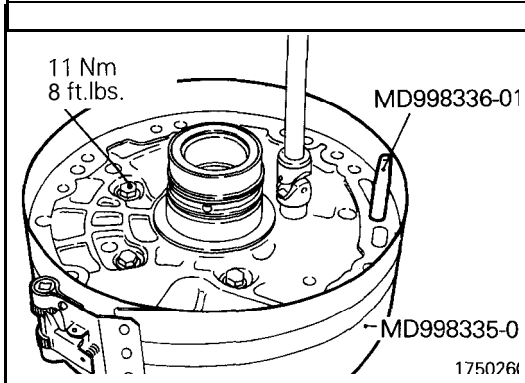

◆D◆ REACTION SHAFT SUPPORT INSTALLATION

- (1) Assemble the reaction shaft support and the pump housing, and tighten the five bolts by fingers.
- (2) Insert the special tool (Guide Pin MD998336) in the oil pump bolt hole and tighten the peripheries of the support and housing with the special tool (Band MD998335) to locate the support and housing.
- (3) Tighten the five bolts to the specified torque.
- (4) Make sure that the oil pump gear turns freely.

◆E◆ O-RING INSTALLATION

- (1) Install a new O-ring in the groove of the pump housing and apply petrolatum jelly to the O-ring.

FRONT CLUTCH

DISASSEMBLY AND REASSEMBLY

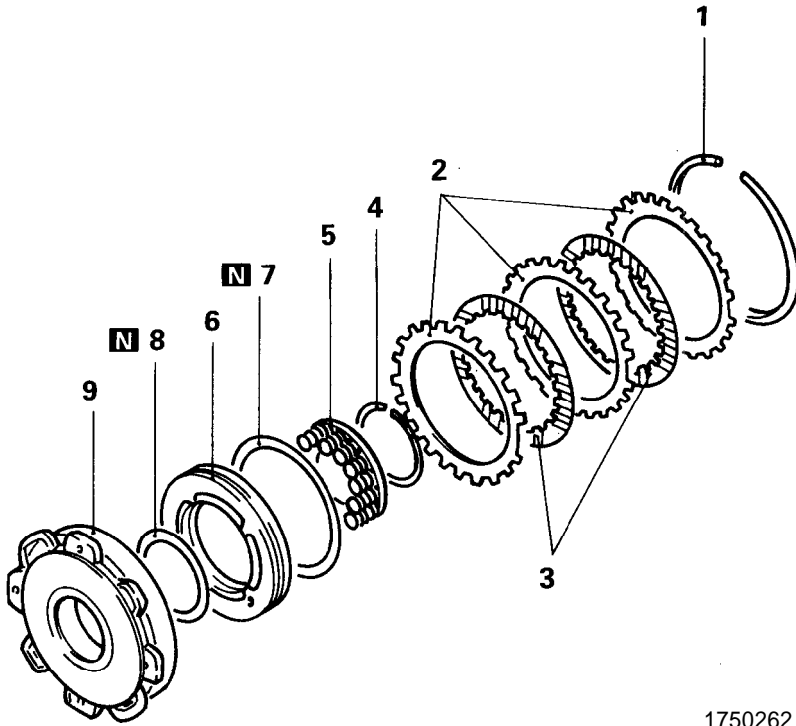

Disassembly steps

- ◆C◆ 1. Snap ring
- ◆B◆ 2. Clutch reaction plate
- 3. Clutch disc
- ◁A▷◆A◆ 4. Snap ring
- 5. Return spring
- 6. Front clutch piston
- 7. D-ring
- 8. D-ring
- 9. Front clutch retainer

1750262

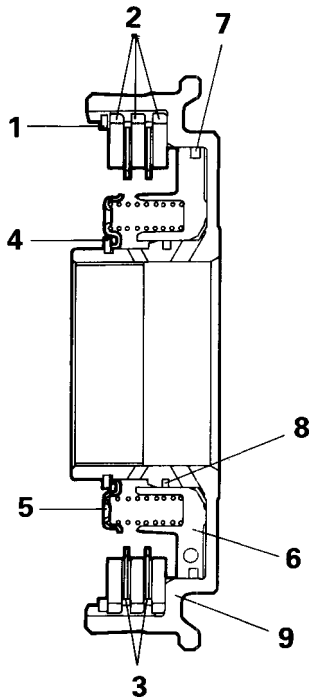

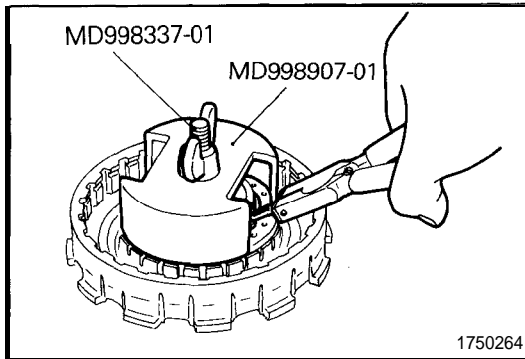

DISASSEMBLY SERVICE POINT

◀A▶ SNAP RING REMOVAL

- (1) Compress the return spring with the special tool.
- (2) Remove the snap ring.

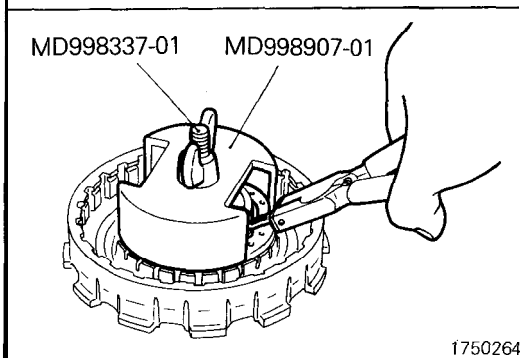

REASSEMBLY SERVICE POINTS

▶A▶ SNAP RING INSTALLATION

- (1) Compress the return spring with the special tool.
- (2) Install the snap ring.

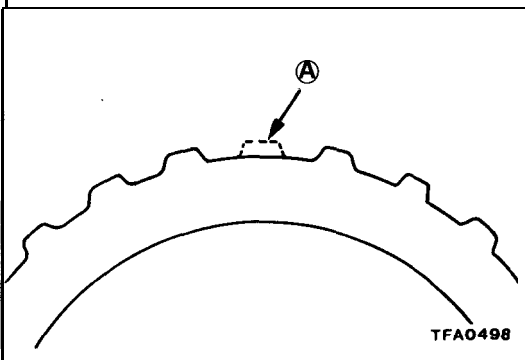

▶B▶ CLUTCH REACTION PLATE INSTALLATION

- (1) Install the clutch reaction plate with their missing tooth portions (A) in alignment.

NOTE

This design is to facilitate escape of automatic transmission fluid and improve the cooling efficiency of the plate and disc.

- (2) Install the innermost the reaction plate with their shear droops directed as shown in the illustration.

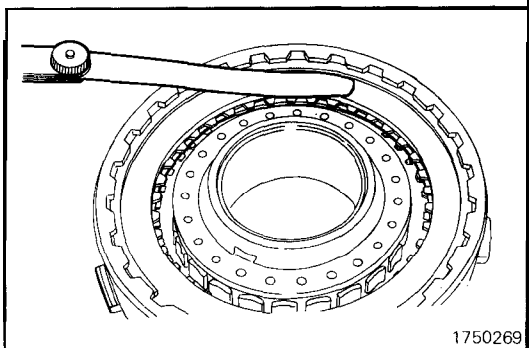
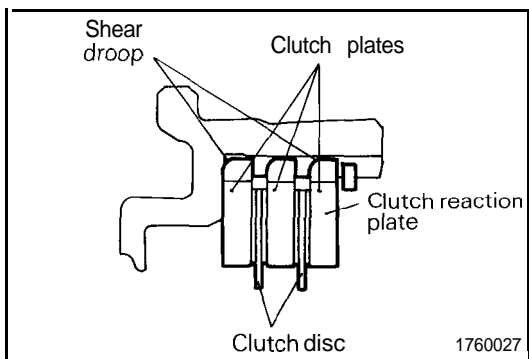

▶C▶ SNAP RING SELECTION

- (1) Check clearance between the snap ring and clutch reaction plate. To check the clearance, hold entire circumference of the clutch reaction plate down with 50 N (11 lbs.) force. If clearance is out of standard value, select a snap ring to obtain the standard value.

Standard value: 0.7 – 0.9 mm (.028 – .035 in.)

REAR CLUTCH

DISASSEMBLY AND REASSEMBLY

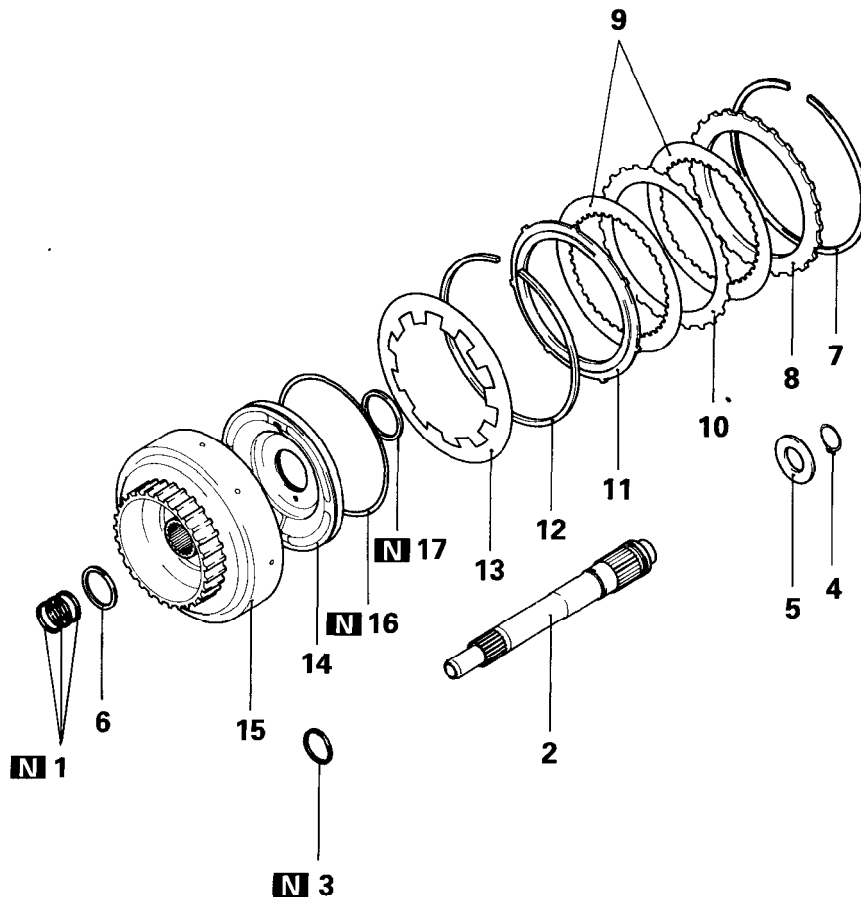

TFA0704

Disassembly steps

- 1. Seal ring
- ◆D◆ 2. Input shaft
- 3. O-ring
- 4. Snap ring
- 5. Thrust race
- 6. Seal ring
- ◆C◆ 7. Snap ring
- ◆B◆ 8. Clutch reaction plate
- 9. Clutch disc
- ◆B◆ 10. Clutch plate
- ◆B◆ 11. Clutch pressure plate
- ◆A◆ 12. Wave spring
- ◆A◆ 13. Return spring
- 14. Rear clutch piston
- 15. Rear clutch retainer
- 16. D-ring
- 17. D-ring

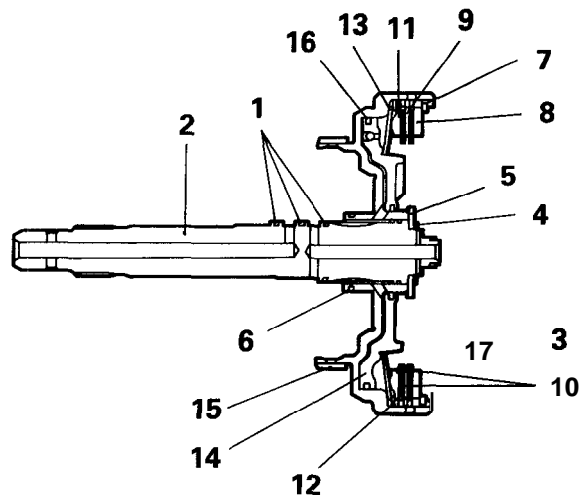

TFA0011

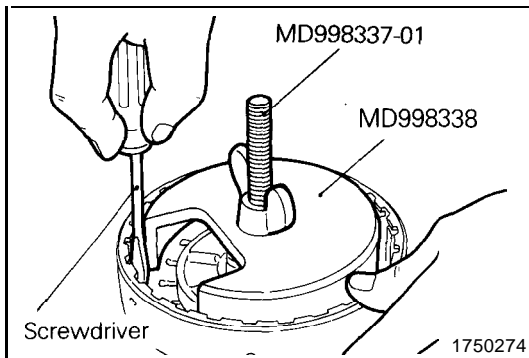

DISASSEMBLY SERVICE POINT

◆A◆ WAVE SPRING REMOVAL

- (1) Compress the return spring with the special tool.
- (2) Using a screwdriver, remove the wave spring.

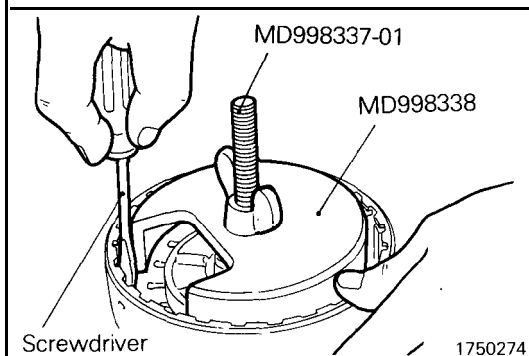

REASSEMBLY SERVICE POINTS

◆A◆ WAVE SPRING INSTALLATION

- (1) Compress clutch reaction plate with the special tool.
- (2) Install the wave spring.

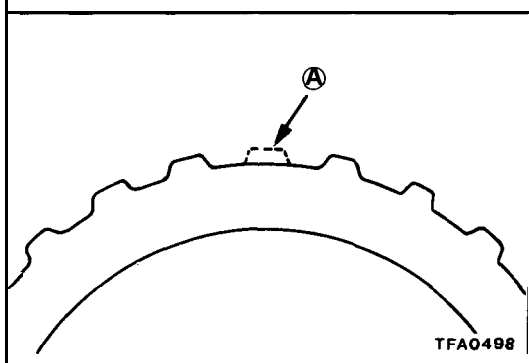

◆B◆ CLUTCH PRESSURE PLATE / CLUTCH PLATE CLUTCH REACTION PLATE INSTALLATION

- (1) Install the clutch pressure plate, clutch plates and clutch reaction plate with their missing tooth portions (A in the illustration) in alignment.

NOTE

This design is to facilitate escape of automatic transmission fluid and improve the cooling efficiency of the plates and disc.

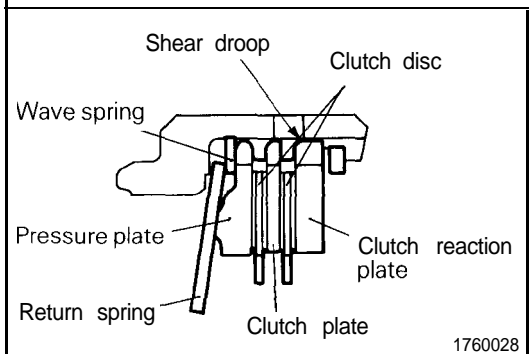

- (2) Install the clutch reaction plate with its shear droop directed as shown in the illustration.

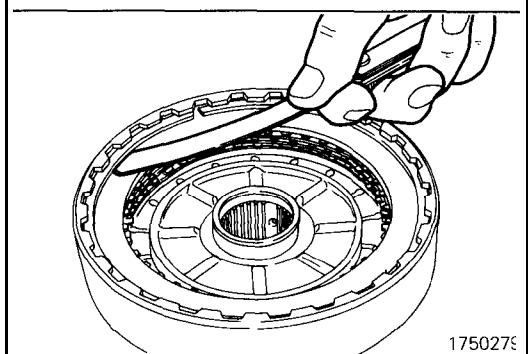

◆C◆ SNAP RING SELECTION

- (1) Check clearance between the snap ring and clutch reaction plate. To check the clearance, hold entire circumference of the clutch reaction plate down with 50 N (11 lbs.) force. If clearance is out of standard value, select a snap ring to obtain the standard value.

Standard value: 0.4 – 0.6 mm (.016 – .024 in.)

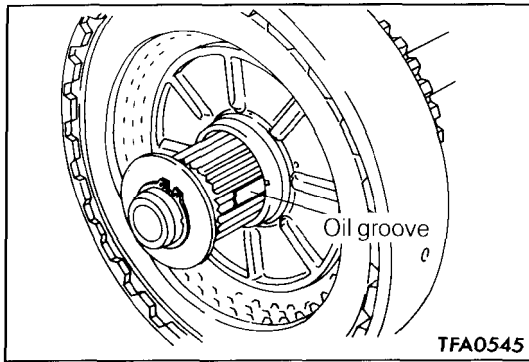
**◆◆ INPUT SHAFT INSTALLATION**

- (1) Install the input shaft with its oil groove aligned with the oil hole in the rear clutch retainer.

**PLANETARY GEAR
DISASSEMBLY AND REASSEMBLY**

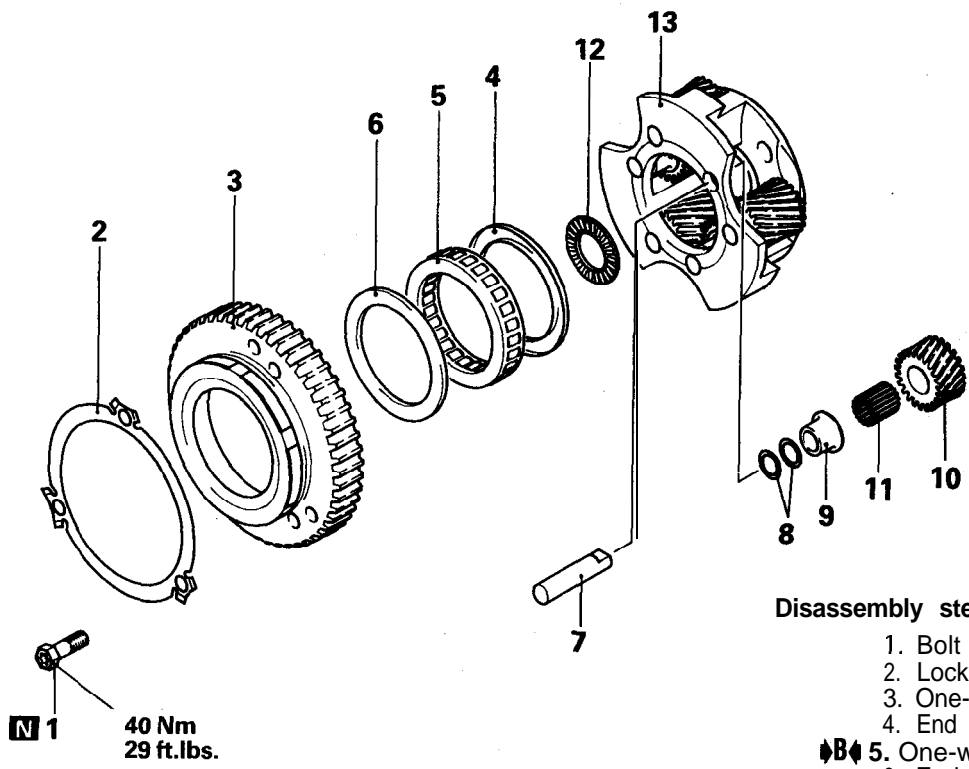

TFA0522

Disassembly steps

1. Bolt
2. Lock plate
3. One-way clutch outer race
4. End plate
- ◆B◆ 5. One-way clutch
6. End plate
7. Pinion shaft
8. Front thrust washer
9. Spacer bushing
10. Short pinion
11. Roller
- ◁A▷◆A◆ 12. Thrust bearing
13. Planet carrier

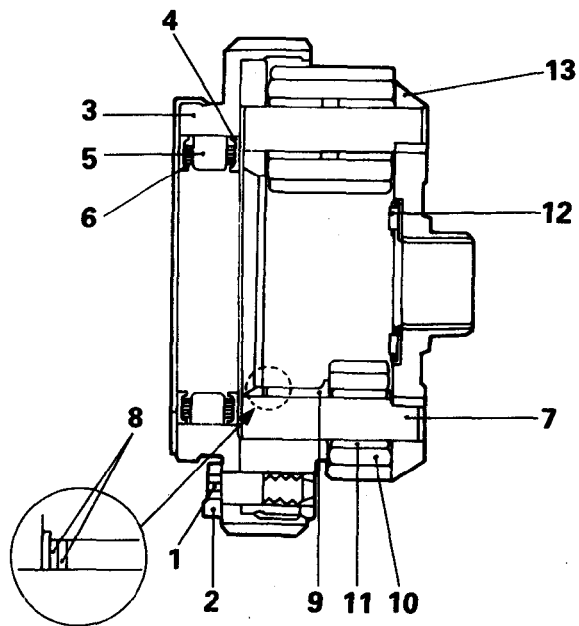

TFA0524

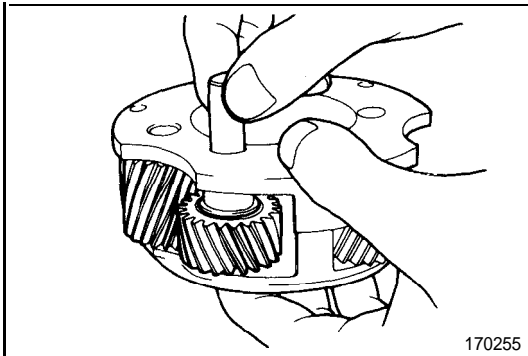

170255

DISASSEMBLY SERVICE POINT**⇄A⇄ THRUST BEARING REMOVAL**

- (1) Remove the only one short pinion. Use care not to drop and lose the 17 rollers in the short pinion. Do not remove the other short pinions,

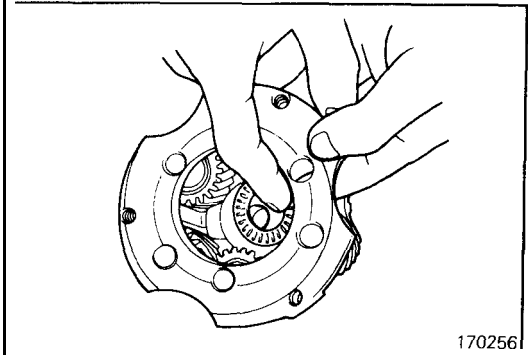

170256

- (2) Remove the thrust bearing.

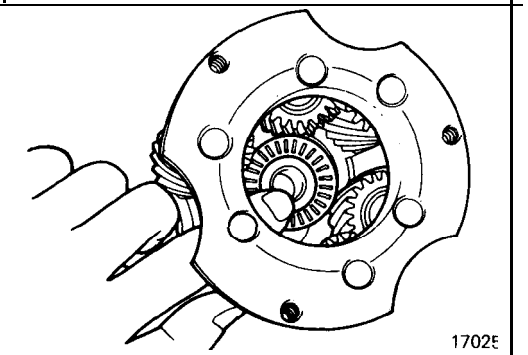

1702E

REASSEMBLY SERVICE POINTS**◆A◆ THRUST BEARING INSTALLATION**

- (1) Install a new thrust bearing on the carrier. Make sure that it fits correctly in the spot faced portion of the carrier.

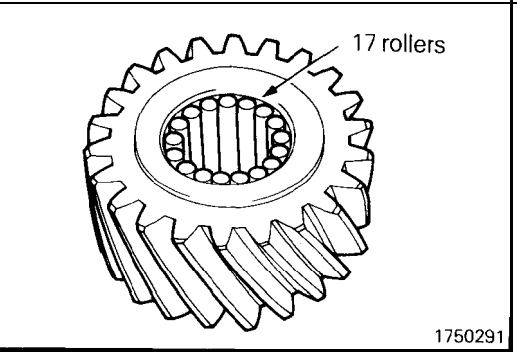

1750291

- (2) Apply vaseline unsparingly to the inside surface of the short pinion and attach the 17 rollers on the surface.

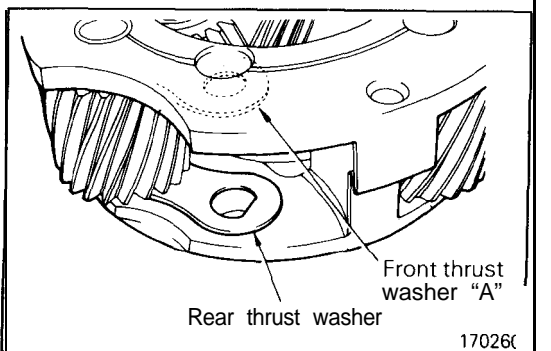

17026C

- (3) Line up the holes of the rear thrust washer and front thrust washer "A" with the shaft hole of the carrier.
- (4) Install the short pinion, spacer bushing and front thrust washer and align the holes. Use care not to allow the rollers to get out of position.

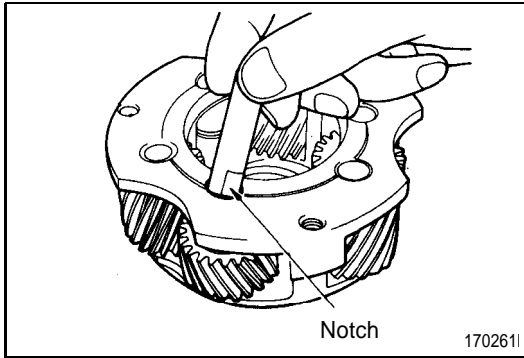

- (5) Insert the pinion shaft. Make sure that the flattened end of pinion shaft is correctly fitted in the hole of the rear thrust plate when the pinion shafts is inserted.

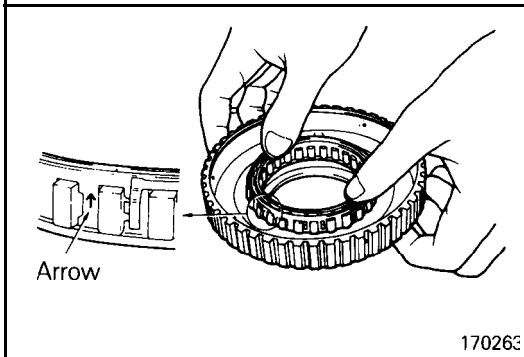

ONE-WAY CLUTCH INSTALLATION

- (1) Push the one-way clutch into the outer race. Make sure that arrow on the outside circumference of cage is directed upward as shown in the illustration when the one-way clutch is pushed in.

ANNULUS GEAR AND TRANSFER DRIVE GEAR SET

DISASSEMBLY AND REASSEMBLY

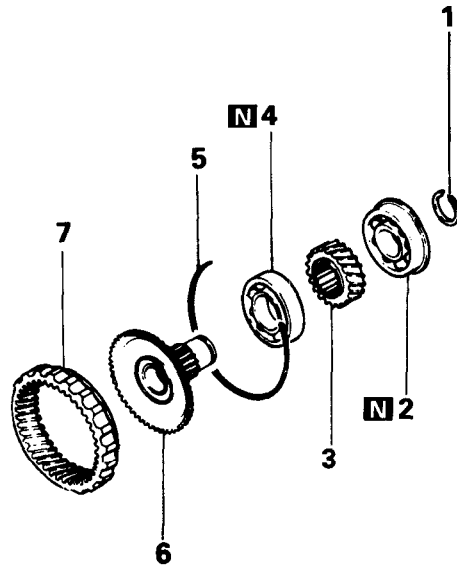

- Disassembly steps**
- 1. Snap ring
 - 2. Bearing
 - 3. Transfer drive gear
 - 4. Bearing
 - 5. Snap ring
 - 6. Output flange
 - 7. Annulus gear

170178

DISASSEMBLY SERVICE POINTS

◁A▷ BEARING REMOVAL

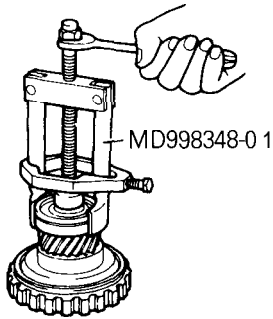

17011

◁B▷ TRANSFER DRIVE GEAR REMOVAL

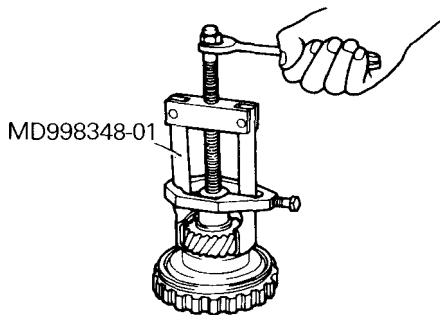

1701

◁C▷ BEARING REMOVAL

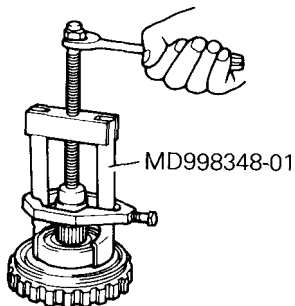

701151

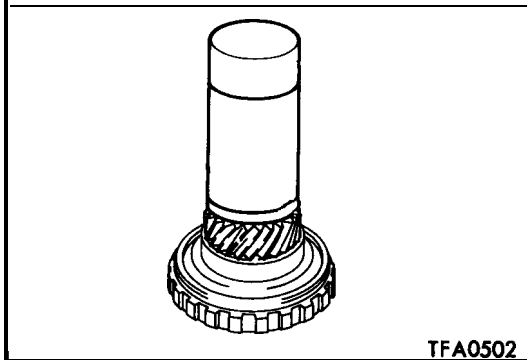

TFA0502

REASSEMBLY SERVICE POINTS

◆A◆ BEARING INSTALLATION

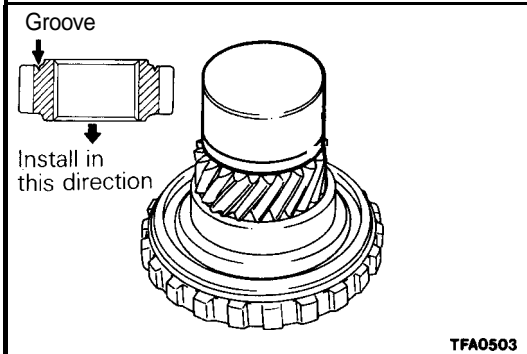

TFA0503

◆B◆ TRANSFER DRIVE GEAR INSTALLATION

- (1) Install the transfer drive gear in proper direction. The direction can be identified by the groove provided in one of the pinion side surfaces.

Caution

Replace the output flange and transfer drive gear as a set.

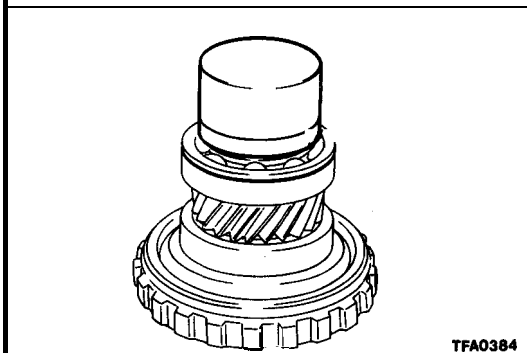

TFA0384

◆C◆ BEARING INSTALLATION

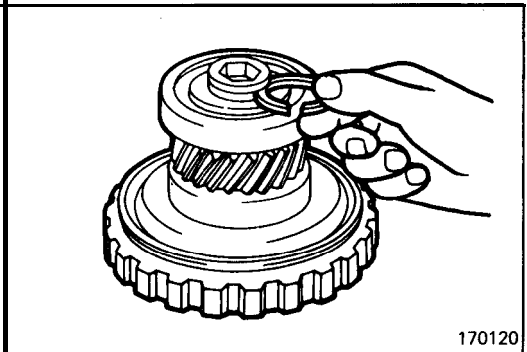

170120

◆D◆ SNAP RING SELECTION

- (1) Select a snap ring, which should be the thickest one that can be installed in groove.

Standard value: 0 – 0.06 mm (0 – .0024 in.)

DIFFERENTIAL

DISASSEMBLY AND REASSEMBLY

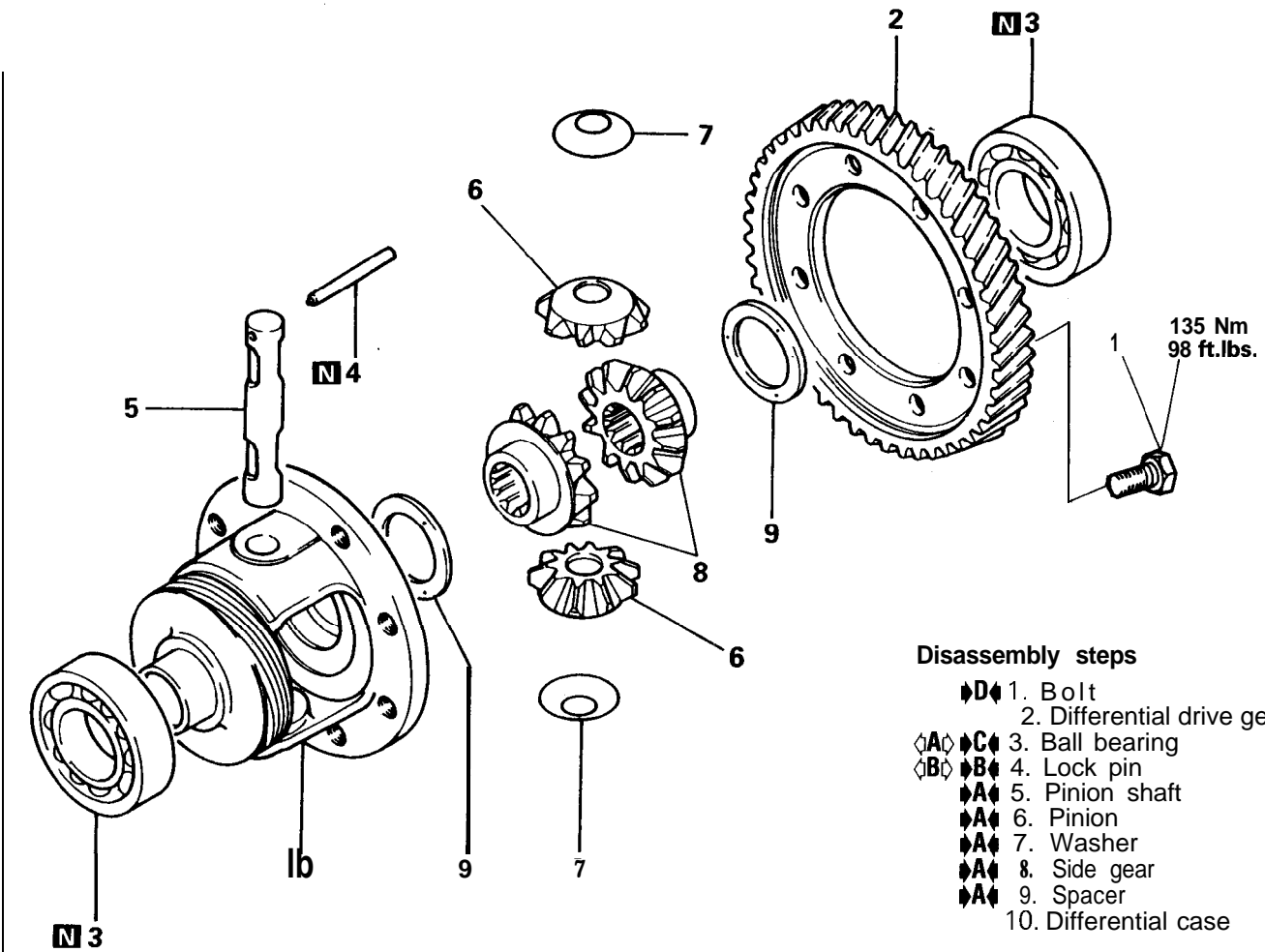

Disassembly steps

- ◆D◆ 1. Bolt
- 2. Differential drive gear
- ◆A◆◆C◆ 3. Ball bearing
- ◆B◆◆B◆ 4. Lock pin
- ◆A◆ 5. Pinion shaft
- ◆A◆ 6. Pinion
- ◆A◆ 7. Washer
- ◆A◆ 8. Side gear
- ◆A◆ 9. Spacer
- 10. Differential case

160015

DISASSEMBLY SERVICE POINTS

◆A◆ **BALL BEARING REMOVAL**

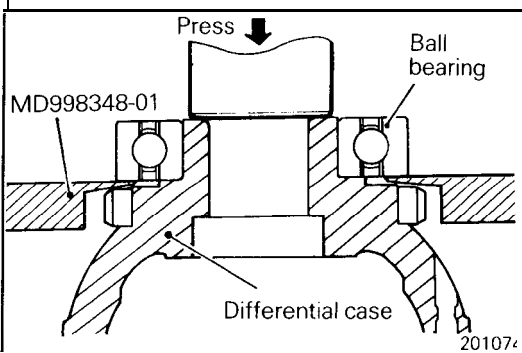

◆B◆ **LOCK PIN REMOVAL**

- (1) Drive out the lock pin with a punch inserted in hole "A".
- (2) Remove the pinion shaft from the case, and remove the pinion gears and washers.
- (3) Remove the side gears and spacers from the case.
Keep the removed gears and spacers for R.H. side use separated from those for L.H. side use.

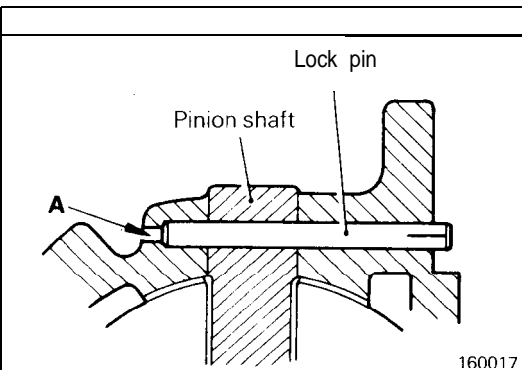

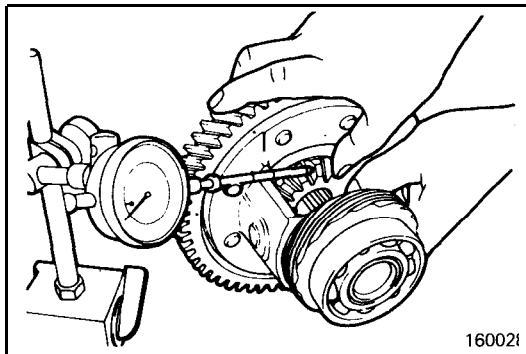

REASSEMBLY SERVICE POINTS

◆A◆ SPACER / SIDE GEAR / WASHER / PINION / PINION SHAFT INSTALLATION

- (1) With the spacers installed on the back of the differential side gears, install the gears in the differential case. When reusing the removed parts, install them in the original positions noted during disassembly. When using new differential side gears, install spacers of medium thickness $1.0^{0}_{-0.07}$ mm ($.039^{0}_{-.003}$ in.).
- (2) Install the washers to the back of the pinion gears, install the gears in the differential case, and then insert the pinion shaft.
- (3) Measure the backlash between the side gear and pinion gear. The backlash should be 0.025 to 0.150 mm (.0010 to .0059 in.) and the right and left gear pairs should have equal backlash. If the backlash is not within the specified range,, disassemble, and reassemble them using spacers selected for correct backlash.

Backlash: 0.025 – 0.150 mm (.0010 – .0059 in.)

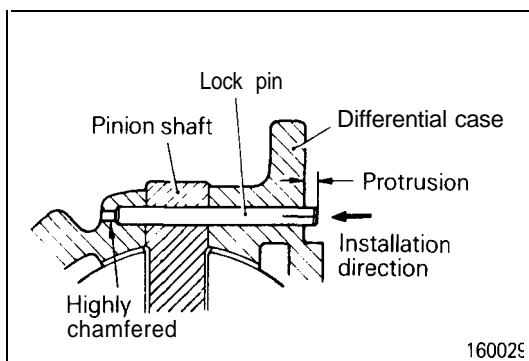

◆B◆ LOCK PIN INSTALLATION

- (1) Align the lock pin hole in the pinion shaft with that in the case and press fit the lock pin until its protrusion is 3 mm (.12 in.) or less.

Caution

1. Do not reuse the lock pin.
2. Do not use a lock pin which requires only 2000 N (440 lbs.) or less force for installation.

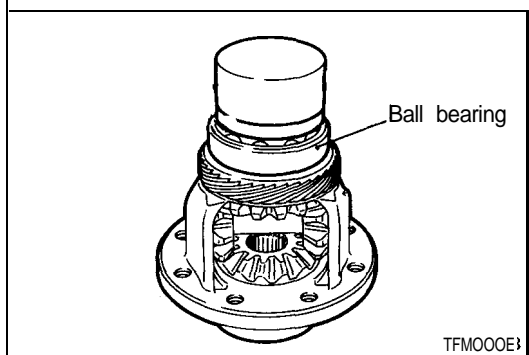

◆C◆ BEARING INSTALLATION

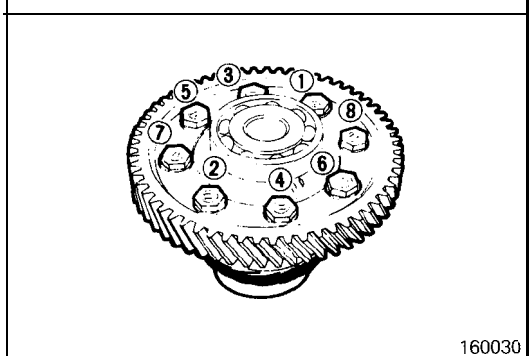

◆D◆ DRIVE GEAR TIGHTENING

- (1) Apply automatic transmission fluid to the bolts and tighten the bolts to the specified torque in the sequence shown in the illustration.

KICKDOWN SERVO

DISASSEMBLY AND REASSEMBLY

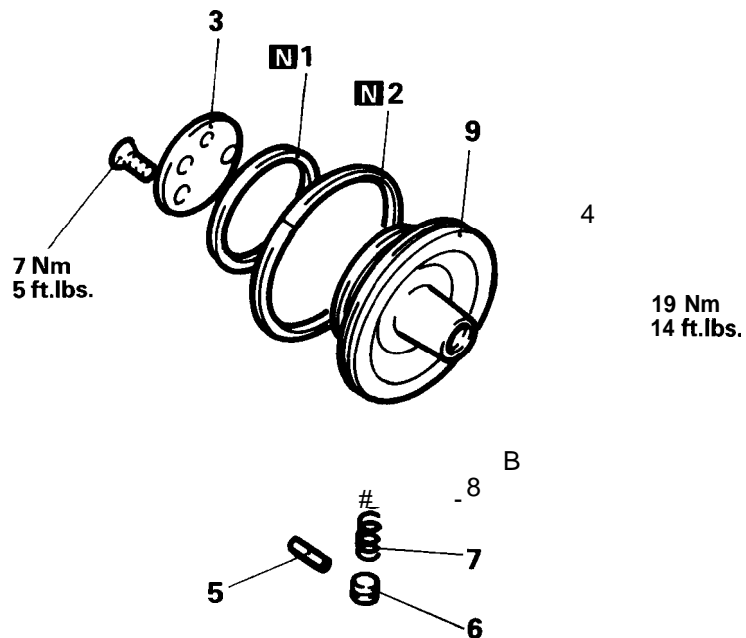

Disassembly steps

1. Seal ring
2. Seal ring
3. Cover
4. Kickdown servo rod
5. Pin
6. Plug
7. Spring
8. Kickdown piston valve
9. Kickdown servo piston

1700055

1700055

LOW-REVERSE BRAKE
DISASSEMBLY AND REASSEMBLY

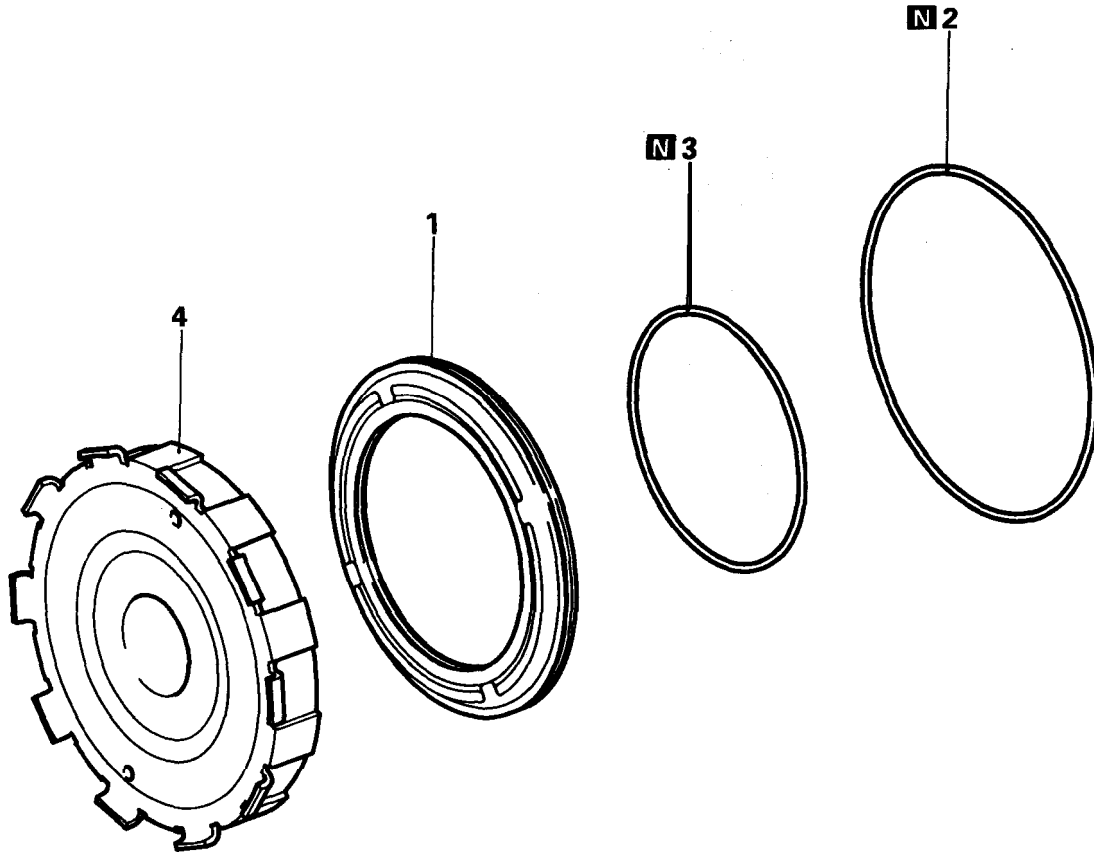

Disassembly steps

1. Low-reverse brake piston
2. D-ring
3. D-ring
4. Center support

TFA0386

SPEEDOMETER GEAR

DISASSEMBLY AND REASSEMBLY

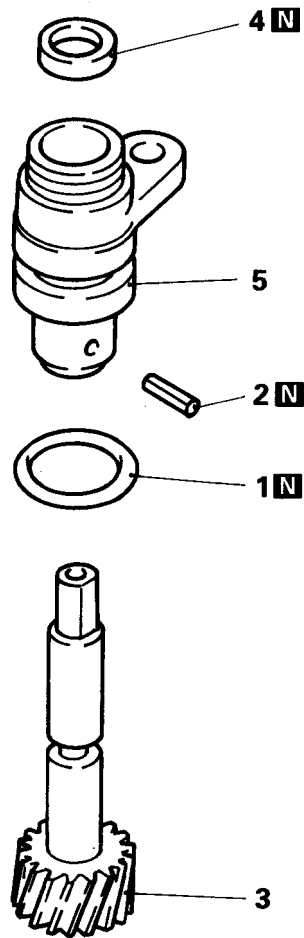

Disassembly steps

- 1. O-ring
- ▶▶ 2. Spring pin
- 3. Driven gear
- 4. Oil seal
- 5. Sleeve

201078

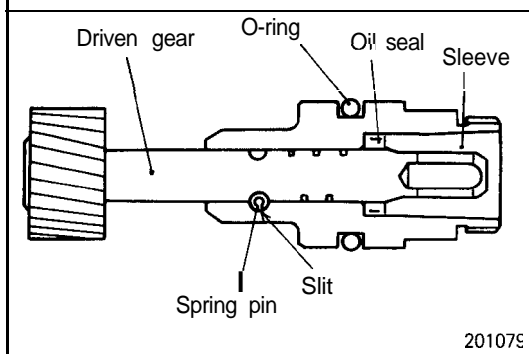

201078

REASSEMBLY SERVICE POINT

▶▶ **SPRING PIN INSTALLATION**

- (1) Drive a new spring pin into the sleeve. Make sure that the slit in the spring pin does not face the gear.

DRIVE SHAFT OIL SEAL

DISASSEMBLY AND REASSEMBLY

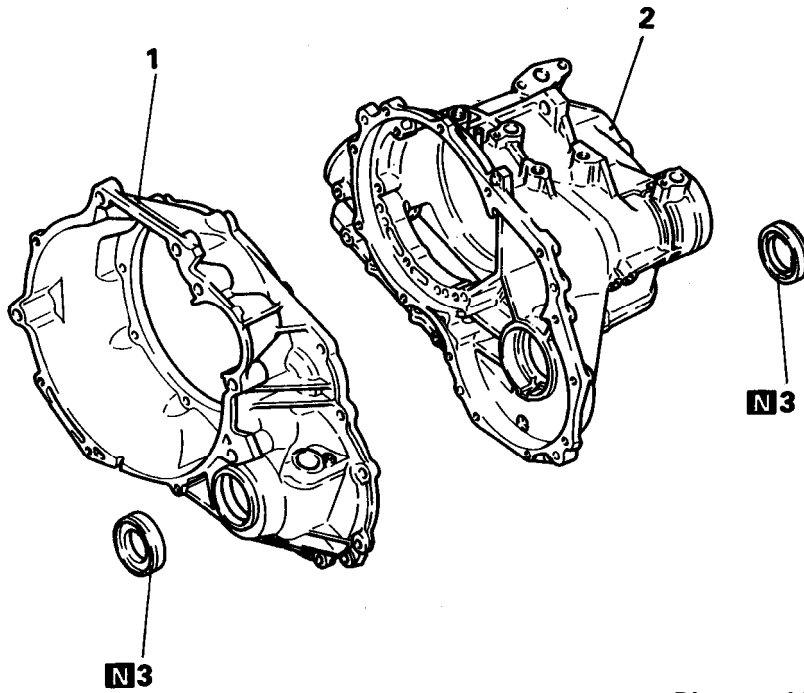

Disassembly steps

1. Converter housing
2. Transmission case
- ▶▶▶ 3. Oil seal

1750298

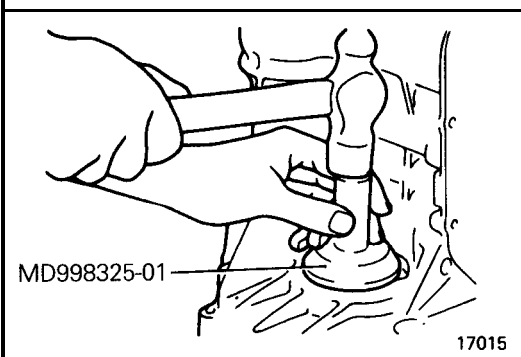

REASSEMBLY SERVICE POINT

▶▶▶ OIL SEAL INSTALLATION

**TRANSFER SHAFT / GOVERNOR
DISASSEMBLY AND REASSEMBLY**

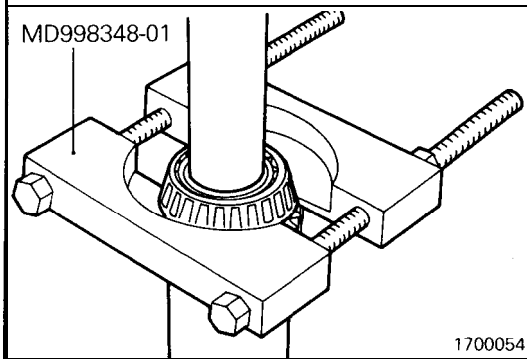
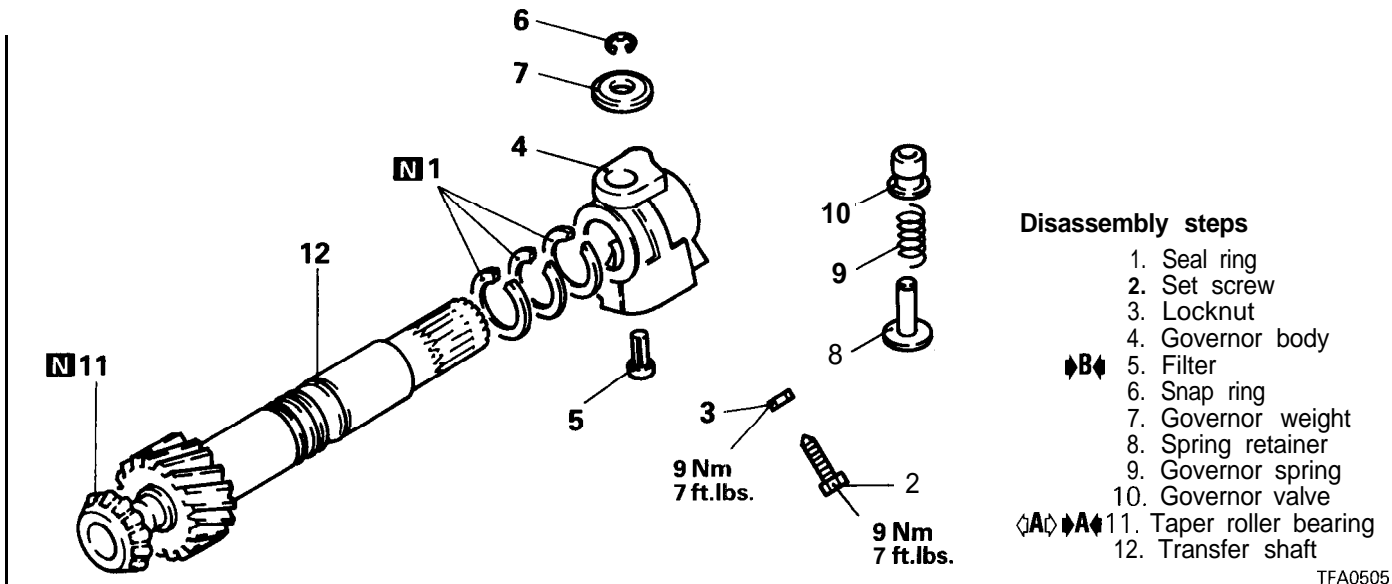

DISASSEMBLY SERVICE POINT

A TAPER ROLLER BEARING REMOVAL

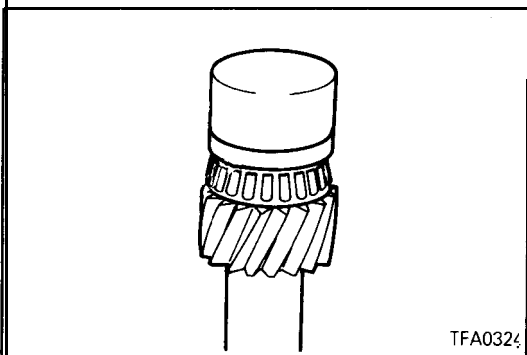

REASSEMBLY SERVICE POINTS

A TAPER ROLLER BEARING INSTALLATION

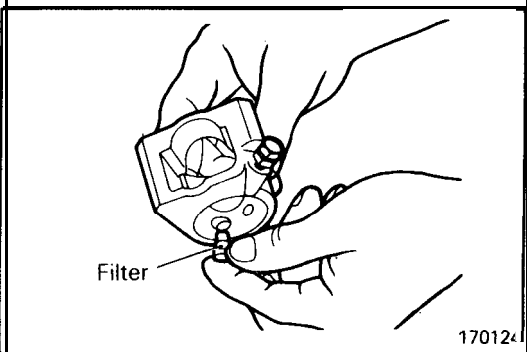

B FILTER INSTALLATION

(1) If dust has accumulated inside the filter, replace it with a new one.

VALVE BODY

DISASSEMBLY AND REASSEMBLY

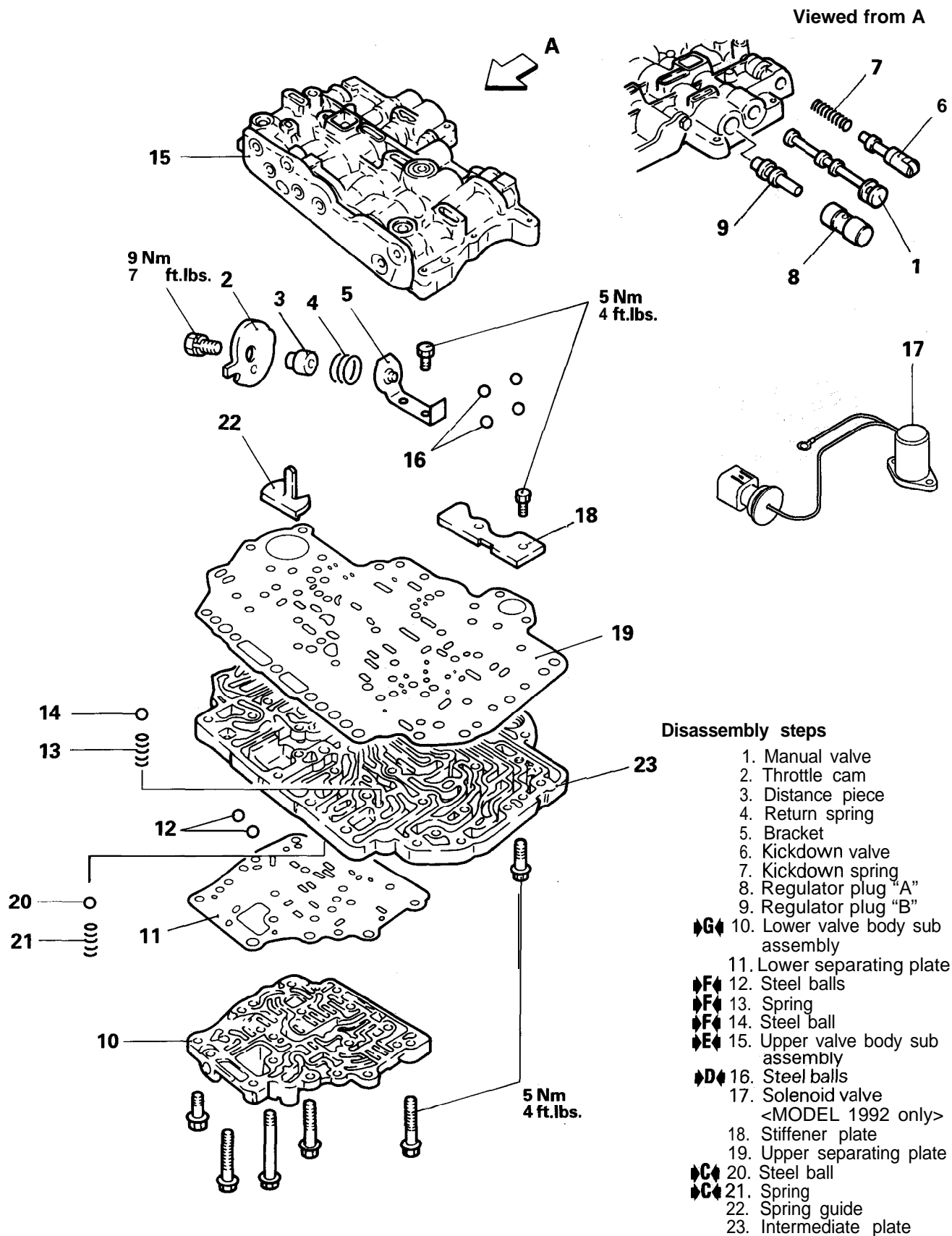

Disassembly steps

1. Manual valve
2. Throttle cam
3. Distance piece
4. Return spring
5. Bracket
6. Kickdown valve
7. Kickdown spring
8. Regulator plug "A"
9. Regulator plug "B"
- ➔G➔ 10. Lower valve body sub assembly
11. Lower separating plate
- ➔F➔ 12. Steel balls
- ➔F➔ 13. Spring
- ➔F➔ 14. Steel ball
- ➔E➔ 15. Upper valve body sub assembly
- ➔D➔ 16. Steel balls
17. Solenoid valve
18. Stiffener plate
19. Upper separating plate
- ➔C➔ 20. Steel ball
- ➔C➔ 21. Spring
22. Spring guide
23. Intermediate plate

TFA0705

TSB Revision

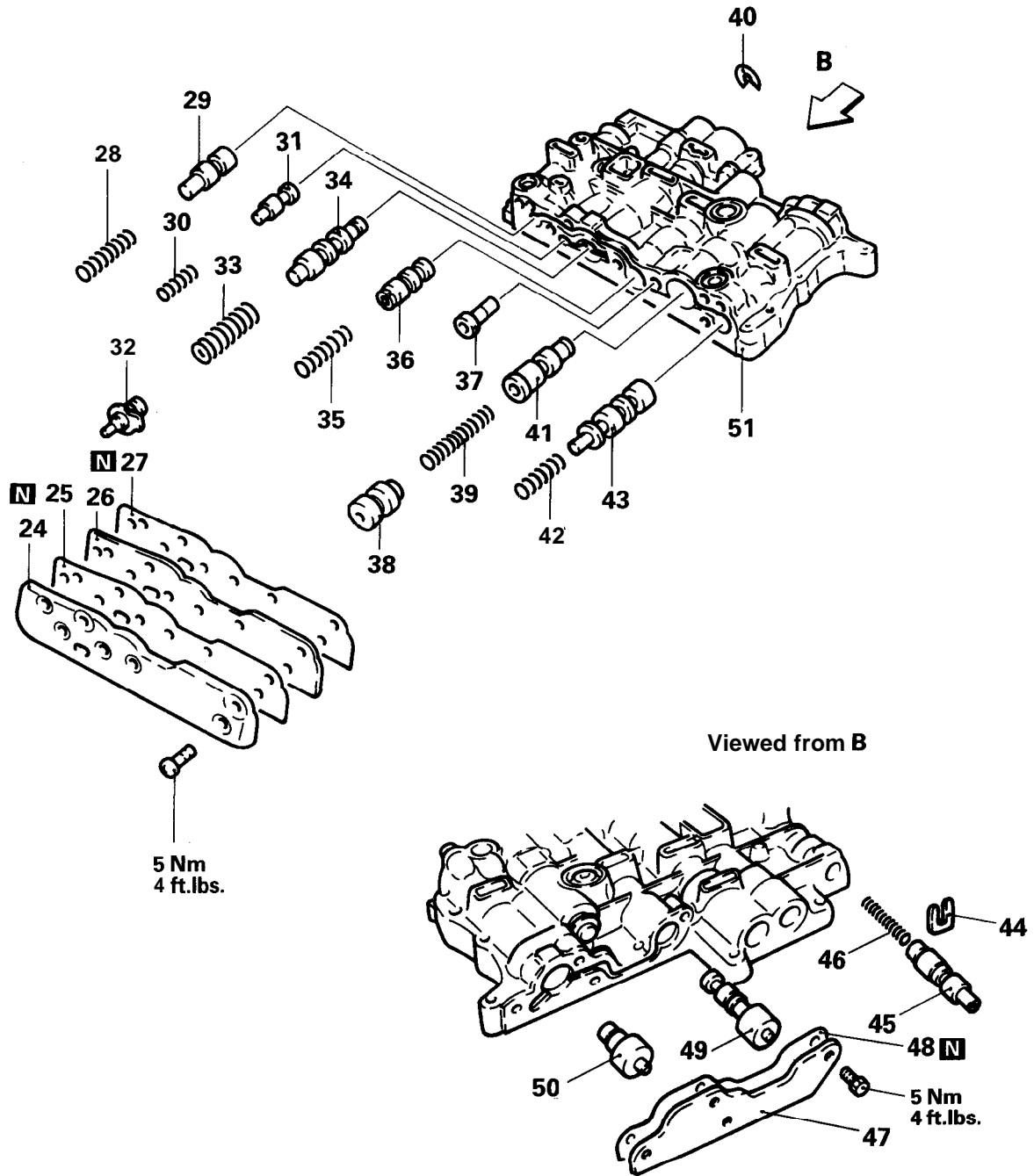

- 24. Front end cover
- 25. Front end cover gasket
- 26. Front end plate
- 27. Front end plate gasket
- 28. Range control spring
- 29. Range control valve
- 30. Torque converter control spring
- 31. Torque converter control valve
- 32. Line pressure adjusting screw
- 33. Regulator spring
- 34. Regulator valve
- 35. 1-2 shift spring
- 36. 1-2 shift plug
- 37. Filter

- 38. Engine brake valve
- 39. 2-3 control spring
- 40. Snap ring
- 41. 2-3 control valve
- 42. 2-3 shift spring
- 43. 2-3 shift valve
- 44. Stopper plate
- 45. Throttle valve
- 46. Throttle spring
- 47. Rear end cover
- 48. Gasket
- 49. 1-2 shift valve
- 50. 2-3 shift plug
- 51. Upper valve body

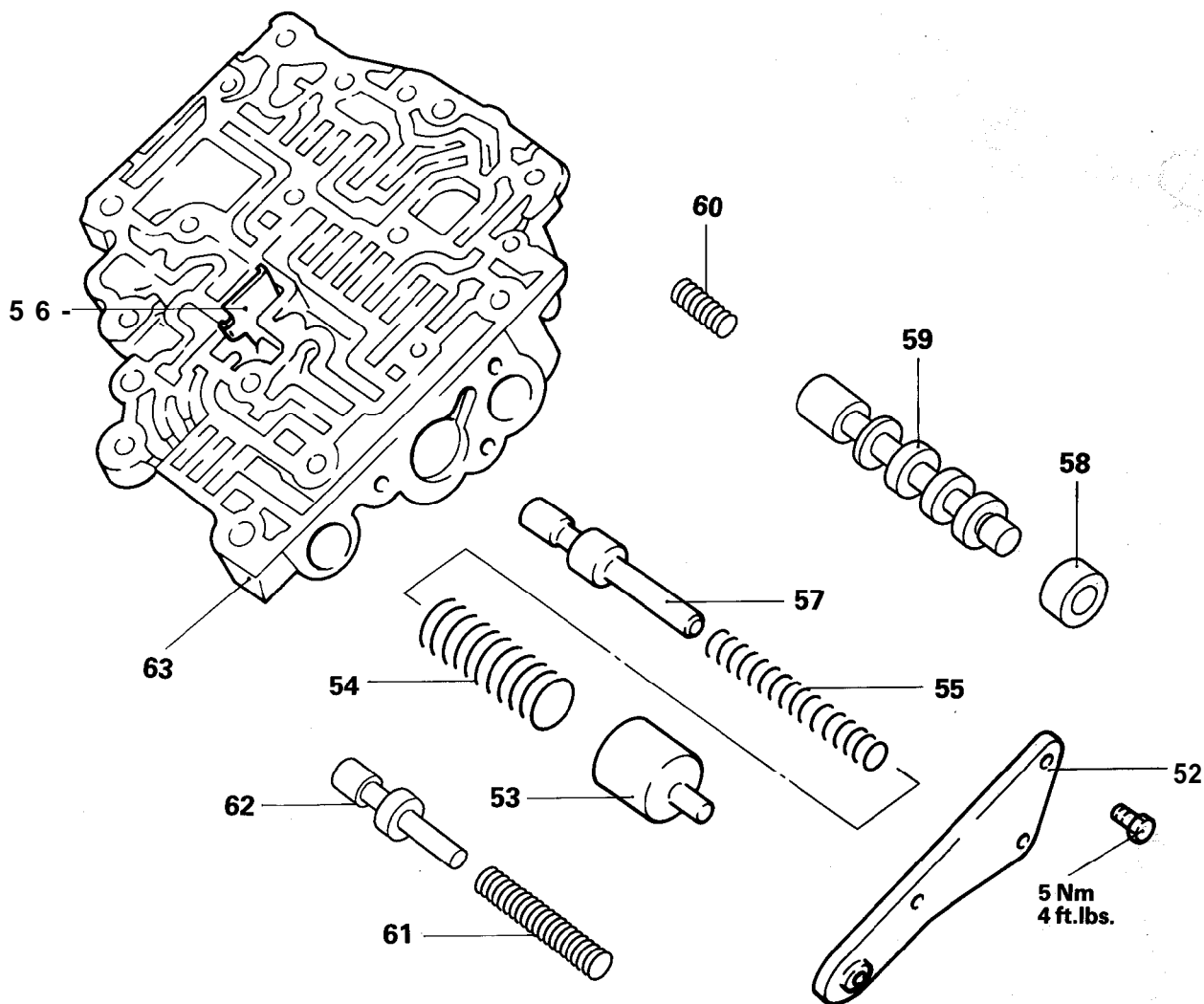

- 52. End cover
- 53. Accumulator plug
- 54. Accumulator spring
- 55. Accumulator spring
- ▶▶ 56. Stopper plate
- 57. Accumulator valve
- 58. Sleeve
- 59. Clutch control valve } <MODEL 1992 only>
- 60. Clutch control spring }
- 61. Reducing spring
- 62. Reducing valve
- 63. Lower valve body

TFA0706

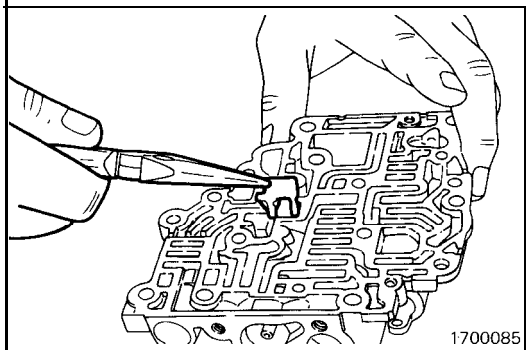

REASSEMBLY SERVICE POINTS
 ▶▶ STOPPER PLATE INSTALLATION

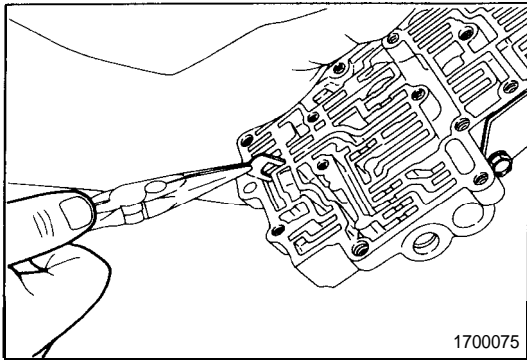

▶B◀ STOPPER PLATE INSTALLATION

1700075

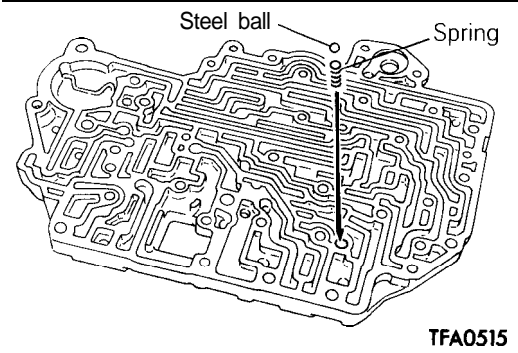

▶C◀ SPRING / STEEL BALL LOCATION

TFA0515

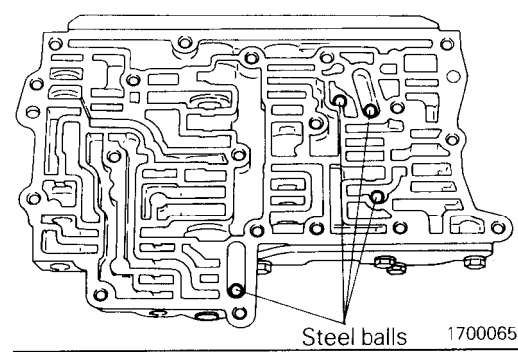

▶D◀ STEEL BALLS LOCATION

Steel balls 1700065

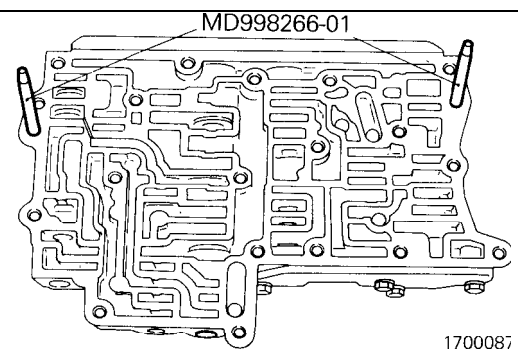

▶E◀ UPPER VALVE BODY SUB ASSEMBLY INSTALLATION

(1) Install the special tools on the upper valve body.

1700087

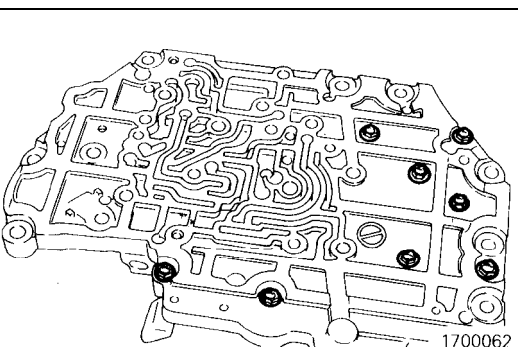

(2) Fasten the upper valve body, intermediate plate and upper separating plate together with the eight bolts. Remove the special tools.

1700062

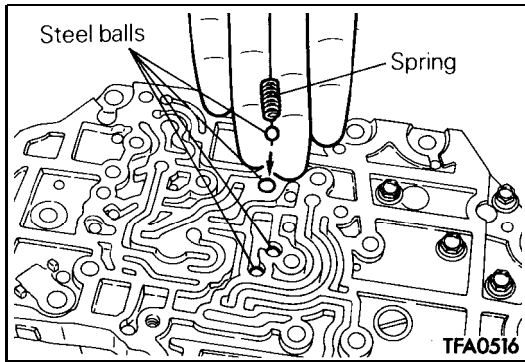

F STEEL BALL / SPRING LOCATION

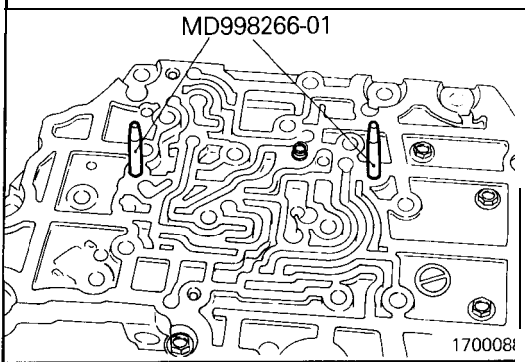

G LOWER VALVE BODY SUB ASSEMBLY INSTALLATION

(1) Install the special tools on the intermediate plate.

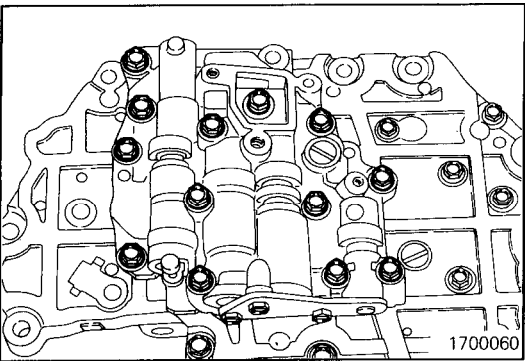

(2) Secure the lower valve body with the 13 bolts. Remove the special tools.

NOTES

AUTOMATIC TRANSAXLE

F4A21, F4A22, F4A23

CONTENTS

ANNULUS GEAR AND TRANSFER		SPECIFICATIONS	7
DRIVE GEAR SET	69	ADJUSTING PRESSURE PLATE, SNAP RINGS AND SPACERS	10
DIFFERENTIAL	71	GEAR RATIO TABLE	7
DRIVE SHAFT OIL SEAL	77	SERVICE SPECIFICATIONS	8
END CLUTCH	64	TRANSAXLE MODEL TABLE	7
FRONT CLUTCH	58	TORQUE SPECIFICATIONS	14
GENERAL INFORMATION	2	VALVE BODY SPRING IDENTIFICATION	9
KICKDOWN SERVO	75	SPEEDOMETER GEAR	76
LOW-REVERSE BRAKE	74	TRANSAXLE	19
OIL PUMP	56	TRANSFER DRIVEN GEAR	79
PLANETARY GEAR	66	TRANSFER SHAFT	78
REAR CLUTCH	61	VALVE BODY	80
SPECIAL TOOLS	15		

GENERAL INFORMATION

Precautions to be taken when disassembling and reassembling the transaxle

- Because the automatic transaxle is composed of component parts of an especially high degree of precision, these parts should be very carefully handled during disassembly and assembly so as not to scar or scratch them.
- A rubber mat should be placed on the workbench, and it should always be kept clean.
- During disassembly, cloth gloves or shop towels should not be used. If such items must be used, either use articles made of nylon, or use paper towels.
- All disassembled parts must be thoroughly cleaned.
Metal parts may be cleaned with ordinary detergents, but must be thoroughly air dried.
- Clean the clutch disc, resin thrust plate and rubber parts by using ATF (automatic transaxle fluid), being very careful that dust, dirt, etc. do not adhere to them.
- Do not reuse gaskets, oil seals, or rubber parts.
Replace such parts with new ones at every reassembly. The O-ring of the oil level gauge need not be replaced.
- Do not use grease other than petrolatum jelly.
- Apply ATF to friction components, rotating parts, and sliding parts before installation.
- A new clutch disc should be immersed in ATF for at least two hours before installation.
- Do not apply sealer or adhesive to gaskets.
- When a bushing must be replaced, replace the assembly in which it is incorporated.
- If the transaxle main unit is damaged, also disassemble and clean the cooler system.

SECTIONAL VIEW – F4A21

7/1/74

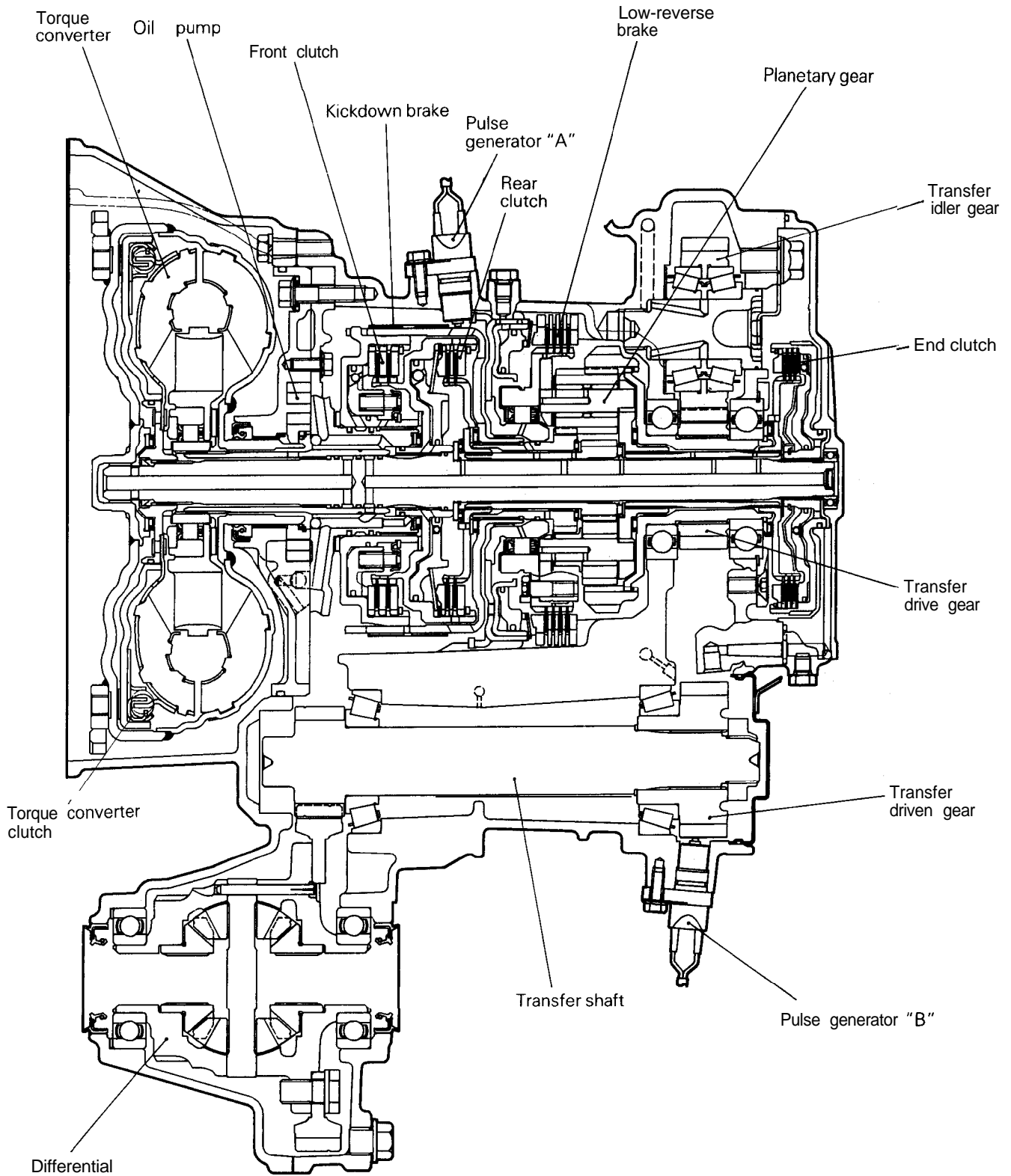

SECTIONAL VIEW – F4A22

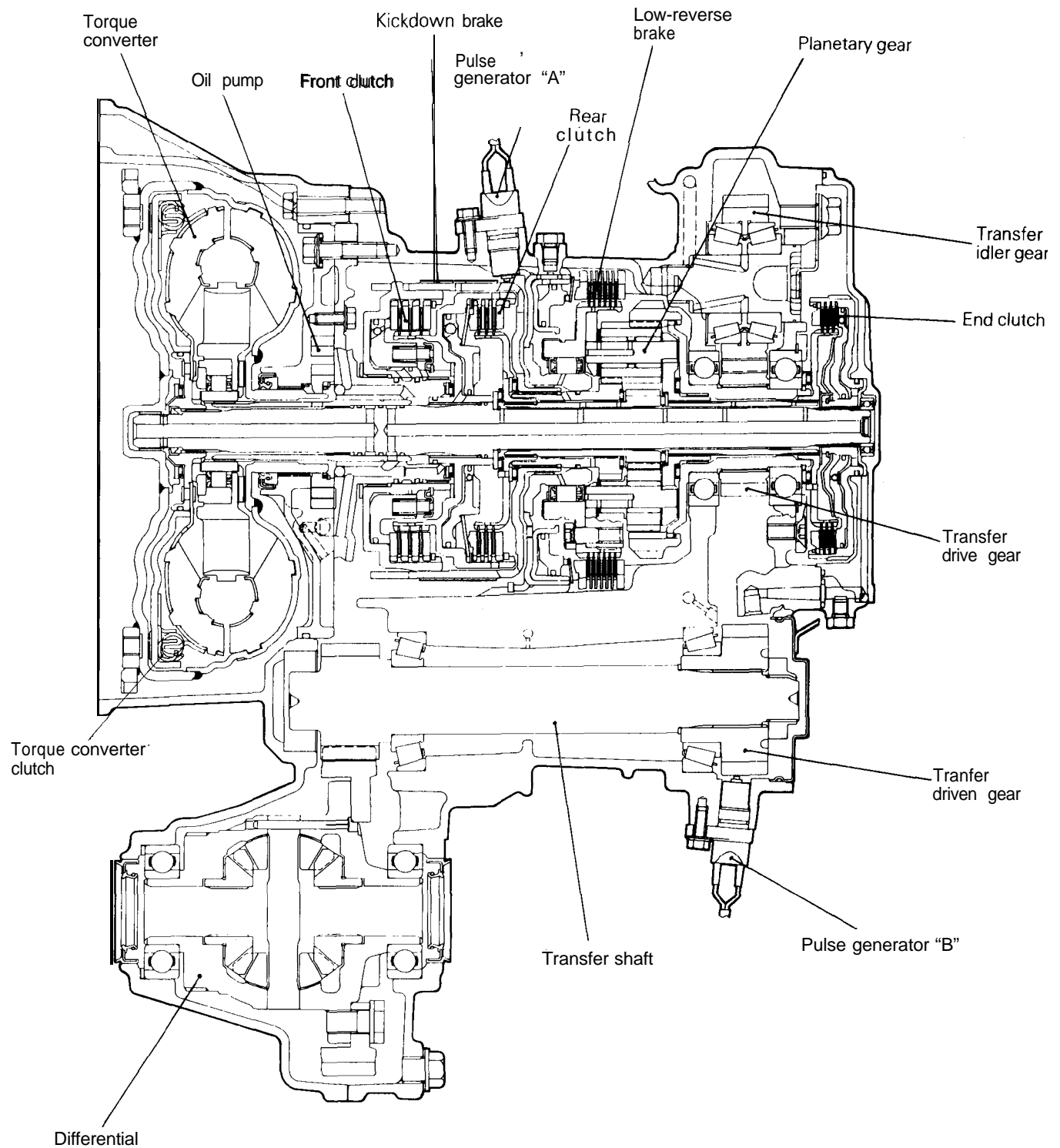

SECTIONAL VIEW – F4A23

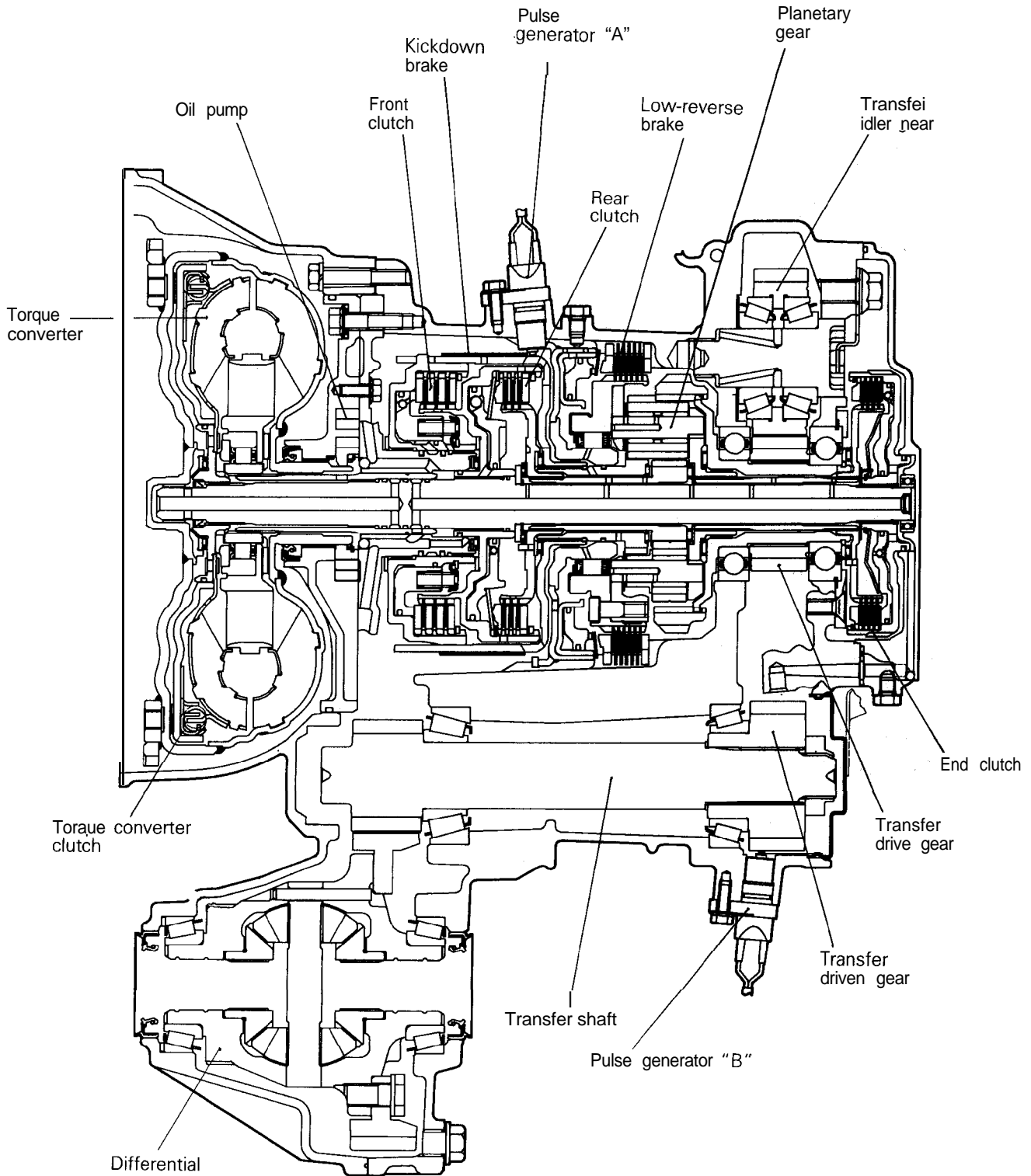

HYDRAULIC CONTROL SYSTEM

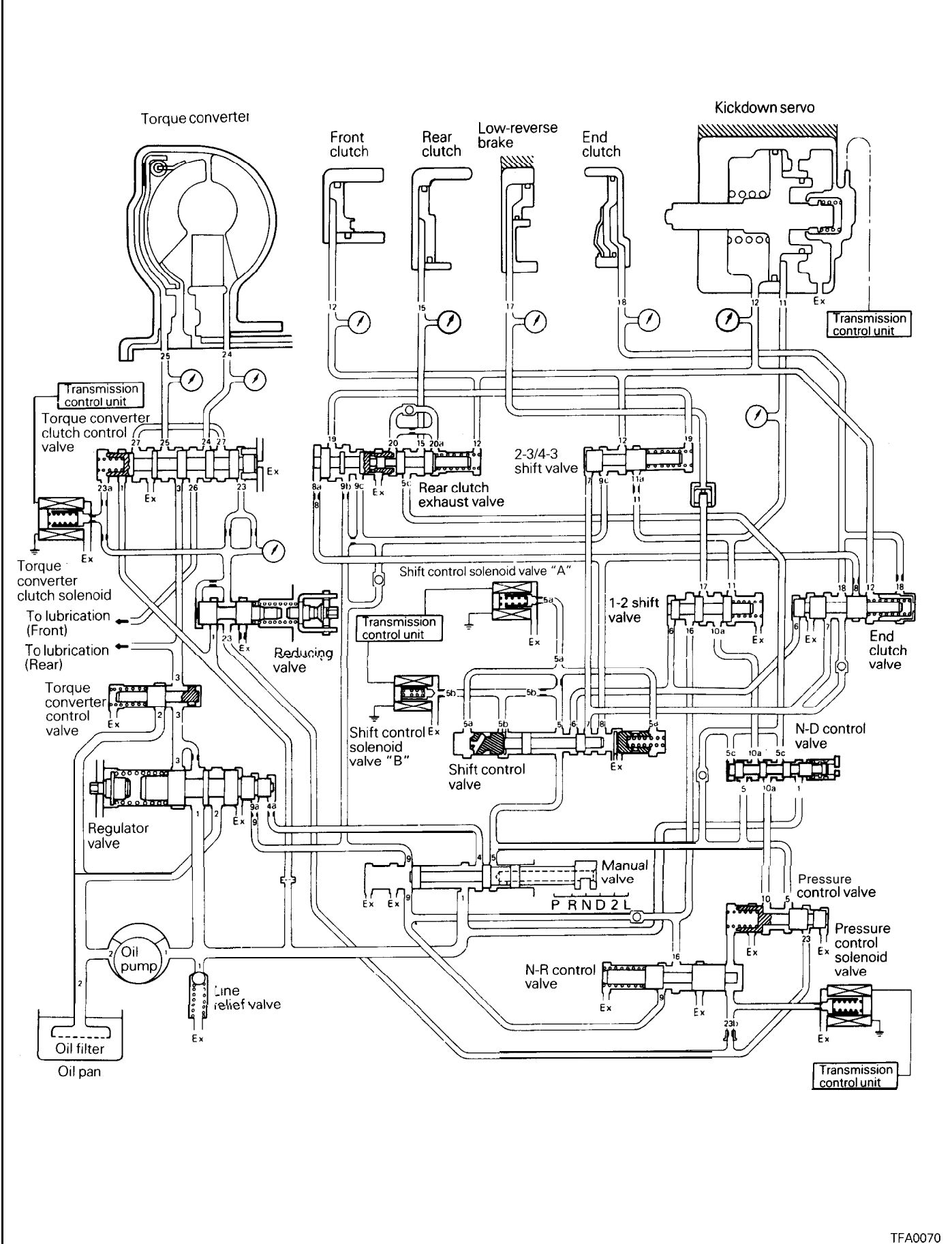

SPECIFICATIONS**TRANSAXLE MODEL TABLE – MODEL 1992**

Transaxle model	Gear ratio	Speedometer gear ratio	Final gear ratio	Vehicle model	Engine model
F4A21-2-MRD1	A	31/36	4.062	C62A	4G15
URD	A	31/36	4.367	C63A	4G61-DOHC
F4A22-2-UND	A	28/36	4.350	N11W	4G93
MPD3	A	29/36	4.007	E33A	4G63
MQD6	A	30/36	4.007	E33A	4G63-DOHC
MPD	A	29/36	4.007	D21A	4G37
MPD1	A	29/36	4.007	D22A	4G63-DOHC
F4A23-2-LNN	B	28/36	3.900	N34W	4G64

TRANSAXLE MODEL TABLE – MODEL 1993

Transaxle model	Gear ratio	Speedometer gear ratio	Final gear ratio	Vehicle model	Engine model
F4A22-2-MRF3	A	31/36	4.007	CB5A	4G93
UNF1	A	28/36	4.350	N11W	4G93
MPE4	A	29/36	4.007	E33A	4G63
MQE	A	30/36	4.007	E33A	4G63-DOHC
MPE	A	29/36	4.007	D21A	4G37
MPE1	A	29/36	4.007	D22A	4G63-DOHC
F4A23-2-LNQ	B	28/36	3.900	N14W, N34W	4G64

GEAR RATIO TABLE

	A	B
1st	2.846	2.551
2nd	1.581	1.488
3rd	1.000	1.000
4th	0.685	0.685
Reverse	2.176	2.176

SERVICE SPECIFICATIONS

mm (in.)

			Standard
Transfer idler gear bearing preload	Nm (ft.lbs.)	F4A21, F4A22	0.8 (.6)
		F4A23	1.5 (1.1)
Input shaft end play			0.3 – 1.0 (.012 – .039)
Transfer shaft end play			0 – 0.025 (0 – .001)
Low-reverse brake end play		F4A22, F4A23	1.0 – 1.2 (.039 – .047)
		F4A21	0.7 – 0.9 (.028 – .035)
Differential case end play			0 – 0.15 (0 – .006)
End clutch snap ring clearance		F4A21, F4A22	0.4 – 0.65 (.016 – .026)
		F4A23	0.6 – 0.85 (.024 – .031)
Oil pump gear side clearance			0.03 – 0.05 (.001 – .002)
Front clutch snap ring clearance		F4A22, F4A23	0.7 – 0.9 (.028 – .035)
		F4A21	0.4 – 0.6 (.016 – .023)
Rear clutch snap ring clearance		F4A22, F4A23	0.4 – 0.6 (.016 – .023)
		F4A21	0.3 – 0.5 (.012 – .020)
Output flange bearing end play			0 – 0.06 (0 – .002)
Differential pinion backlash			0.025 – 0.150 (.001 – .006)
Pulse generator resistance			245 ohm at 20°C (68°F)
Pressure control solenoid valve resistance			Approx. 3 ohm at 20°C (68°F)
Shift control solenoid valve resistance			Approx. 22 ohm at 20°C (68°F)
Torque converter clutch solenoid resistance			
MODEL 1992 and MODEL 1993 – E33A, D21A, D22A			Approx. 3 ohm at 20°C (68°F)
MODEL 1993 – C35A, N11W, N14W, N34W			Approx. 13 ohm at 20°C (68°F)

VALVE BODY SPRING IDENTIFICATION

-mm (in.)

	Free height	Outside diameter	Number of loops	Wire diameter
Regulator valve spring	52 (2.047)	15 (.591)	11	1.4 (.055)
Torque converter control valve spring	22.6 (.890)	9.0 (.354)	9.5	1.3 (.051)
Pressure control valve spring	21.3 (.839)	7.6 (.299)	8	0.45 (.018)
Rear clutch exhaust valve spring	27.4 (1.079)	6.8 (.268)	12	0.7 (.028)
2-3 shift valve spring	27.5 (1.083)	7.0 (.276)	15	0.8 (.031)
End clutch valve spring (F4A2 1, F4A22)	24.4 (.961)	6.6 (.260)	15.5	0.7 (.028)
End clutch valve spring (F4A23)	24.4 (.961)	6.6 (.260)	15.5	0.6 (.024)
1-2 shift valve spring	26.6 (1.047)	7.6 (.299)	13	0.6 (.024)
Reducing valve spring	33.4 (1.315)	11 (.433)	9	1.0 (.039)
N-R control valve spring	32.1 (1.264)	9.2 (.362)	8	0.7 (.028)
Shift control valve spring	26.8 (1.055)	5.7 (.224)	22	0.5 (.020)
Relief spring	17.3 (.681)	7.0 (.276)	10	1.0 (.039)
Torque converter clutch control valve spring (F4A21, F4A22)	15.7 (.618)	6.2 (.244)	10.5	0.7 (.028)
Torque converter clutch control valve spring (F4A23)	14.2 (.559)	6.2 (.244)	9.5	0.7 (.028)

ADJUSTMENT PRESSURE PLATE, SNAP RINGS AND SPACERS

Part name	Thickness mm (in.)	Identification symbol	Part No.
Pressure plate: F4A21 (For adjustment of low-reverse brake end play)	5.6 (.220)	56	MD731720
	5.7 (.224)	57	MD731721
	5.8 (.228)	58	MD727801
	5.9 (.232)	59	MD731000
	6.0 (.236)	60	MD727802
	6.1 (.240)	61	MD731001
	6.2 (.244)	62	MD727803
	6.3 (.248)	63	MD731002
	6.4 (.252)	64	MD727804
	6.5 (.256)	65	MD731003
	6.6 (.260)	66	MD727805
Pressure plate: F4A22, F4A23 (For adjustment of low-reverse brake end play)	6.7 (.264)	67	MD731004
	6.8 (.268)	68	MD731005
	5.6 (.220)	56	MD731720
	5.7 (.224)	57	MD731721
	5.8 (.228)	58	MD727801
	5.9 (.232)	59	MD731000
	6.0 (.236)	60	MD727802
	6.1 (.240)	61	MD731001
	6.2 (.244)	62	MD727803
	6.3 (.248)	63	MD731002
	6.4 (.252)	64	MD727804
Snap ring For adjustment of front clutch and rear clutch clearance)	6.5 (.256)	65	MD731003
	6.6 (.260)	66	MD727805
	6.7 (.264)	67	MD731004
	6.8 (.268)	68	MD731005
	6.9 (.272)	69	MD734766
	7.0 (.276)	70	MD734767
	1.6 (.063)	None	MD955630
	1.7 (.067)	Brown	MD730930
	1.8 (.071)	Blue	MD955631
	1.9 (.075)	None	MD730931
	2.0 (.079)	Brown	MD955632
	2.1 (.083)	Blue	MD730932
	2.2 (.087)	None	MD955633
	2.3 (.091)	Brown	MD730933
	2.4 (.094)	Blue	MD955634
2.5 (.098)	None	MD730934	
2.6 (.102)	Brown	MD955635	
2.7 (.106)	Blue	MD730935	
2.8 (.110)	None	MD955636	
2.9 (.114)	Brown	MD730936	
3.0 (.118)	Blue	MD955637	

Part name	Thickness mm (in.)	Identification symbol	Part No.
Snap ring (For adjustment of end clutch clearance)	1.05 (.041)	White	MD71 5800
	1.30 (.051)	Yellow	MD715801
	1.55 (.061)	None	MD715802
	1.80 (.071)	Green	MD71 5803
	2.05 (.081)	Pink	MD720849
	Snap ring (For adjustment of output flange bearing end play)	1.82 (.072)	None
1.88 (.074)		Blue	MD721014
1.94 (.076)		Brown	MD721015
2.00 (.079)		None	MD721016
2.06 (.081)		Blue	MD721017
2.12 (.083)		Brown	MD722539
Spacer (For adjustment of transfer shaft preload)	1.20 (.047)	20	MD723160
	1.23 (.048)	23	MD723161
	1.26 (.050)	26	MD723162
	1.29 (.051)	29	MD723163
	1.32 (.052)	32	MD723164
	1.35 (.053)	35	MD723165
	1.38 (.054)	38	MD723166
	1.41 (.056)	41	MD723167
	1.44 (.057)	44	MD723168
	1.47 (.058)	47	MD727169
	1.50 (.059)	50	MD723170
	1.53 (.060)	53	MD723171
	1.56 (.061)	56	MD723172
	1.59 (.063)	59	MD723173
	1.62 (.064)	62	MD723174
	1.65 (.065)	65	MD723175
	1.68 (.066)	68	MD723176
	1.71 (.067)	71	MD723177
1.74 (.069)	74	MD723178	
1.77 (.070)	77	MD723179	
1.80 (.071)	80	MD723180	
Spacer: F4A21 (For adjustment of differential case end play)	1.31 (.052)	E	MD706574
	1.40 (.055)	None	MD706573
	1.49 (.059)	C	MD706572
	1.58 (.062)	B	MD706751
	1.67 (.066)	A	MD706570
	1.76 (.069)	F	MD706575
	1.85 (.073)	H	MD700272
	1.94 (.076)	c c	MD71 5956
	2.03 (.080)	FF	MD725959
	2.12 (.083)	ll	MD71 5962

Part name	Thickness mm (in.)	Identification symbol	Part No.
Spacer: F4A22 (For adjustment of differential case end play)	1.85 (.073)	H	MD700272
	1.94 (.076)	c c	MD71 5956
	2.03 (.080)	FF	MD71 5959
	2.12 (.083)	II	MD71 5962
	2.21 (.087)	LL	MD71 5965
	2.30 (.091)	O O	MD71 5968
	2.39 (.094)	RR	MD71 5971
	2.48 (.098)	u u	MD722736
	2.57 (.101)	x x	MD731402
Spacer: F4A23 (For adjustment of differential case end play)	1.10(.043)	J	MD71 0454
	1.13(.044)	D	MD700270
	1.16(.046)	K	MD710455
	1.19(.047)	L	MD71 0456
	1.22 (.048)	G	MD700271
	1.25 (.049)	M	MD710457
	1.28 (.050)	N	MD710458
	1.31 (.052)	E	MD706574
	1.34 (.053)	O	MD71 0459
	1.37 (.054)	P	MD71 0460
	1.40 (.055)	None	MD706573
	1.43 (.056)	Q	MD71 0461
	1.46 (.057)	R	MD71 0462
	1.49 (.059)	C	MD706572
	1.52 (.060)	S	MD710463
	1.55 (.061)	T	MD71 0464
	1.58 (.062)	B	MD706571
	1.61 (.063)	U	MD71 0465
	1.64 (.065)	V	MD71 0466
	1.67 (.066)	A	MD706570
	1.70 (.067)	W	MD710467
	1.73 (.068)	X	MD71 0468
	1.76 (.069)	F	MD706575
	1.79 (.070)	Y	MD71 0469
	1.82 (.072)	Z	MD710470
	1.85 (.073)	H	MD700272
	1.88 (.074)	AA	MD710471
	1.91 (.075)	BB	MD71 5955
	1.94 (.076)	c c	MD71 5956
	1.97 (.078)	DD	MD71 5957
	2.00 (.079)	EE	MD71 5958
	2.03 (.080)	FF	MD71 5959
2.06 (.081)	GG	MD71 5960	
2.09 (.082)	HH	MD71 5961	
2.12 (.083)	II	MD71 5962	
2.15 (.085)	JJ	MD71 5963	
2.18 (.086)	KK	MD71 5964	





Part name	Thickness mm (in.)	Identification symbol	Part No.
Spacer: F4A23 (For adjustment of differential case end play)	2.21 (.087)	LL	MD715965
	2.24 (.088)	MM	MD71 5966
	2.27 (.089)	NN	MD715967
	2.30 (.091)	0 0	MD71 5968
	2.33 (.092)	PP	MD71 5969
	2.36 (.093)	QQ	MD71 5970
	2.39 (.094)	RR	MD715971
	2.42 (.095)	ss	MD722734
	2.45 (.096)	TT	MD722735
Spacer: F4A21 (For adjustment of differential pinion backlash)	2.48 (.098)	uu	MD722736
	0.75 – 0.82 (.030 – .032)	–	MA1 80862
	0.83 – 0.92 (.033 – .036)	–	MA1 80861
	0.93 – 1.00 (.037 – .039)	–	MA1 80860
	1.01–1.08 (.040 – .043)	–	MA1 80875
Spacer: F4A22, F4A23 (For adjustment of differential pinion backlash)	1.09 – 1.16 (.043 – .047)	–	MA1 80876
	0.75 – 0.82 (.030 – .032)	–	MD722986
	0.83 – 0.92 (.033 – .036)	–	MD722985
	0.93 – 1.00 (.037 – .039)	–	MD722984
	1.01–1.08 (.040 – .043)	–	MD722982
1.09 – 1.16 (.043 – .047)	–	MD722983	



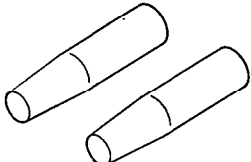
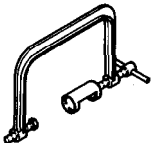
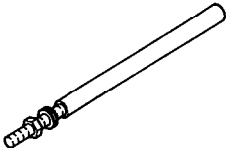
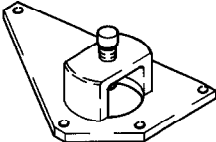
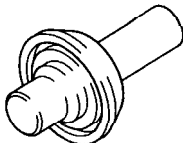
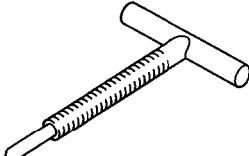
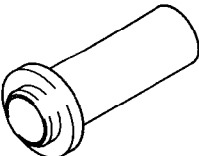
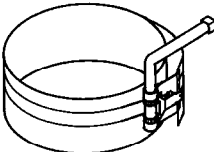
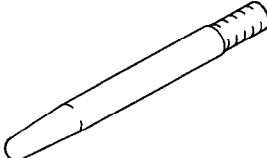

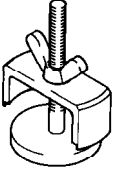
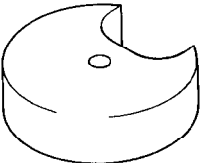

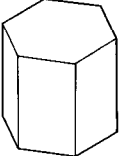
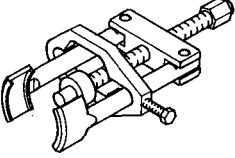
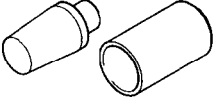
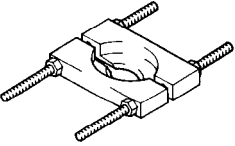

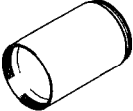
TORQUE SPECIFICATIONS

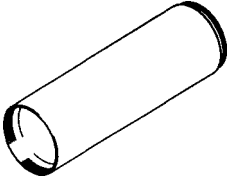
	Nm	ft.lbs.
Manual control shaft set screw	9	7
Sprag rod support bolts	24	18
Idler shaft lock plate bolt	54	40
Transfer shaft lock nut	215	156
Bearing retainer bolts	20	15
Oil pump assembly mounting bolts	21	16
Converter housing bolts	21	16
End clutch cover bolts	7	6
Valve body assembly mounting bolts	11	8
Oil filter bolts	6	5
Oil pan bolts	11	8
Kickdown servo lock nut	29	21
Park/neutral position switch bolts	11	8
Manual control lever nut	19	14
Pulse generator bolts	11	8
Pump housing to reaction shaft support bolts	1	8
Differential drive gear bolts	135	98
One-way clutch outer race lock plate bolts	40	29
Valve body bolts	5	4
Pressure check plug	9	7
Speedometer sleeve locking plate bolt	4	3
Drain plug	33	24
End cover bolts	5	4
Solenoid valve mounting bolts	5	4

SPECIAL TOOLS

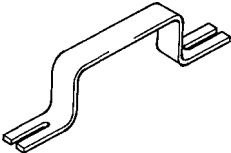
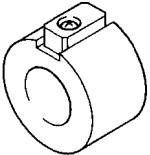
Tool	Number and tool name	Replaced by OTC tool number	Application
	MD998266 Guide pins	MD998266-01	Alignment of intermediate plate and valve body
	MD998303 Valve spring compressor	MD998341-01	Installation and removal of kickdown servo
	MD998316 Dial gauge support	MIT209038	Measurement of low-reverse brake end play
	MD998319 Transfer shaft retainer	MD998319-01	Installation of transfer shaft rear bearing and gear
	MD998325 Differential oil seal installer	MD998325-01	Installation of differential oil seal
	MD998333 Oil pump remover	MD998333-01	Removal of oil pump
	MD998334 Oil seal installer	MD998334-01	Installation oil pump oil seal
	MD998335 Oil pump band	MD998335-01	Installation of oil pump
	MD998336 Guide pin	MD998336-01	Alignment of oil pump housing and reaction shaft support

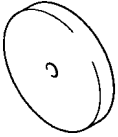
Tool	Number and too name	Replaced by OTC tool number	Application
	MD998337 Spring compressor	MD998337-01	Use with MD998338, MD998907
	MD998338 Spring compressor	MD998338	Disassembly of rear clutch
	MD998341 Kickdown servo adapter set	MD998341-01	Removal and installation of kickdown servo
	MD998344 Wrench adapter "B"	MD998344-01	Removal and installation of transfer idler shaft
	MD998348 Bearing puller	MD998348-0 1	Removal of bearing
	MD998367 Snap ring installer	MD998367-01	Assembly of the end clutch
	MD998301 Bearing remover	MD998348-01	Removal of bearing
	MD998812 Installer cap	General service tool	Use with installer and installer adapter
	MD998813 Installer-100	General service tool	Use with installer cap and installer adapter

Tool	Number and tool name	Replaced by OTC tool number	Application
	MD998814 Installer-200	MIT304180	Use with installer cap and installer adapter
	MD998818 Installer adapter (38)	General service tool	Installation of each bearing
	MD998819 Installer adapter (40)		
	MD998824 Installer adapter (50)		
	M 0998905 Handle	MD998905-01	Removal and installation of center support
	MD998906 Wrench adapter	MD998906-01	Preload measurement of transfer idler shaft
	MD998907 Spring compressor	MD998907-01	Disassembly and reassembly of front clutch
	MD998908 Bearing installer	MD998908-01	Press-in of transfer shaft rear bearing
	MD998910 Bearing installer	MD998910-01	Press-in of transfer shaft rear bearing

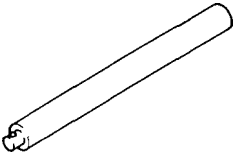
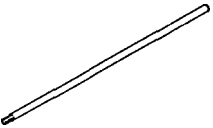
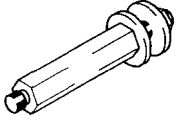
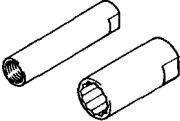
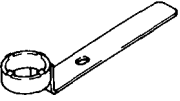
Tool	Number and tool name	Replaced by OTC tool number	Application
	MD998912 Handle	General service tool	Press-in of transfer shaft rear bearing
	MD998913 Dial gauge extension	MD998913-01	Measurement of low-reverse brake end play
	MD998915 Kickdown servo wrench adapter	MD998916-1-01	Adjustment of kickdown servo
	MD998916 Kickdown servo adjust wrench set	MD998916-2-0 1 MD998916-3-0 1	
	MD998918 Kickdown servo wrench	MD998918	

TRANSAXLE

- 1. Torque converter
- 2. Converter housing
- 3. Gasket
- 4. Oil pump
- 5. O-ring
- 6. Gasket
- 7. Thrust washer #1
- 8. Front clutch assembly
- 9. Thrust race #3
- 10. Thrust bearing #4
- 11. Thrust washer #2
- 12. Rear clutch assembly
- 13. Spacer
- 14. Differential

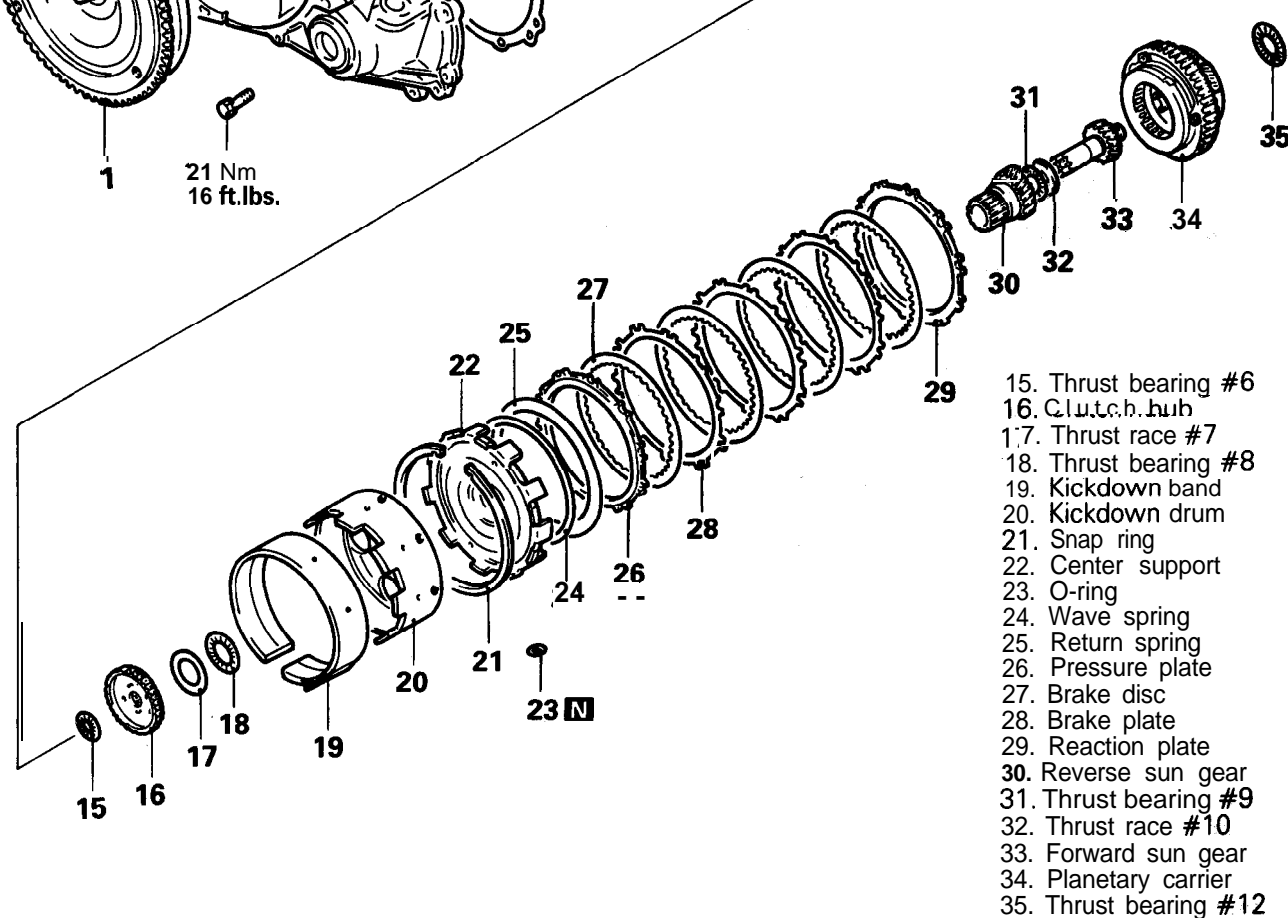
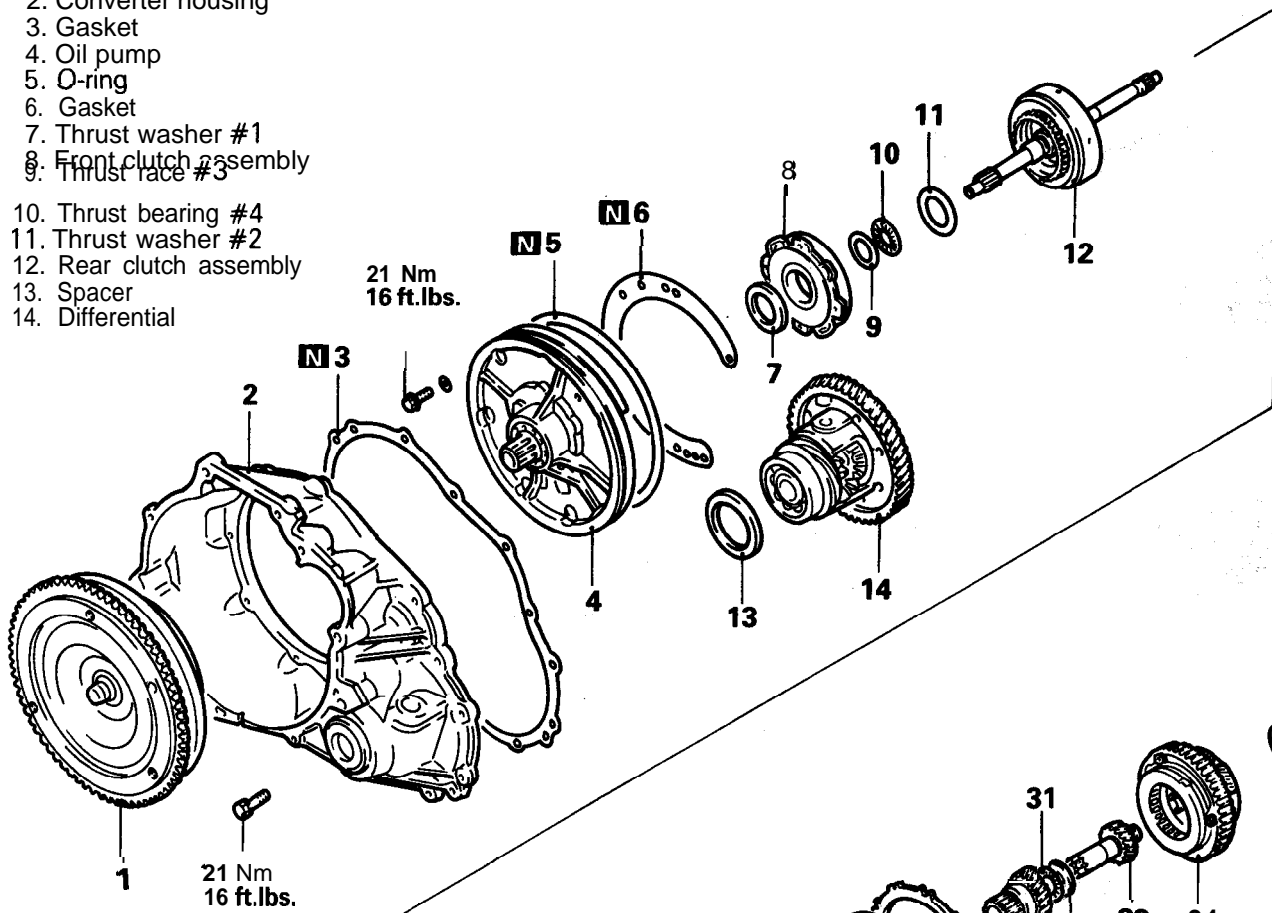

- 15. Thrust bearing #6
- 16. Clutch hub
- 17. Thrust race #7
- 18. Thrust bearing #8
- 19. Kickdown band
- 20. Kickdown drum
- 21. Snap ring
- 22. Center support
- 23. O-ring
- 24. Wave spring
- 25. Return spring
- 26. Pressure plate
- 27. Brake disc
- 28. Brake plate
- 29. Reaction plate
- 30. Reverse sun gear
- 31. Thrust bearing #9
- 32. Thrust race #10
- 33. Forward sun gear
- 34. Planetary carrier
- 35. Thrust bearing #12

TSB Revision

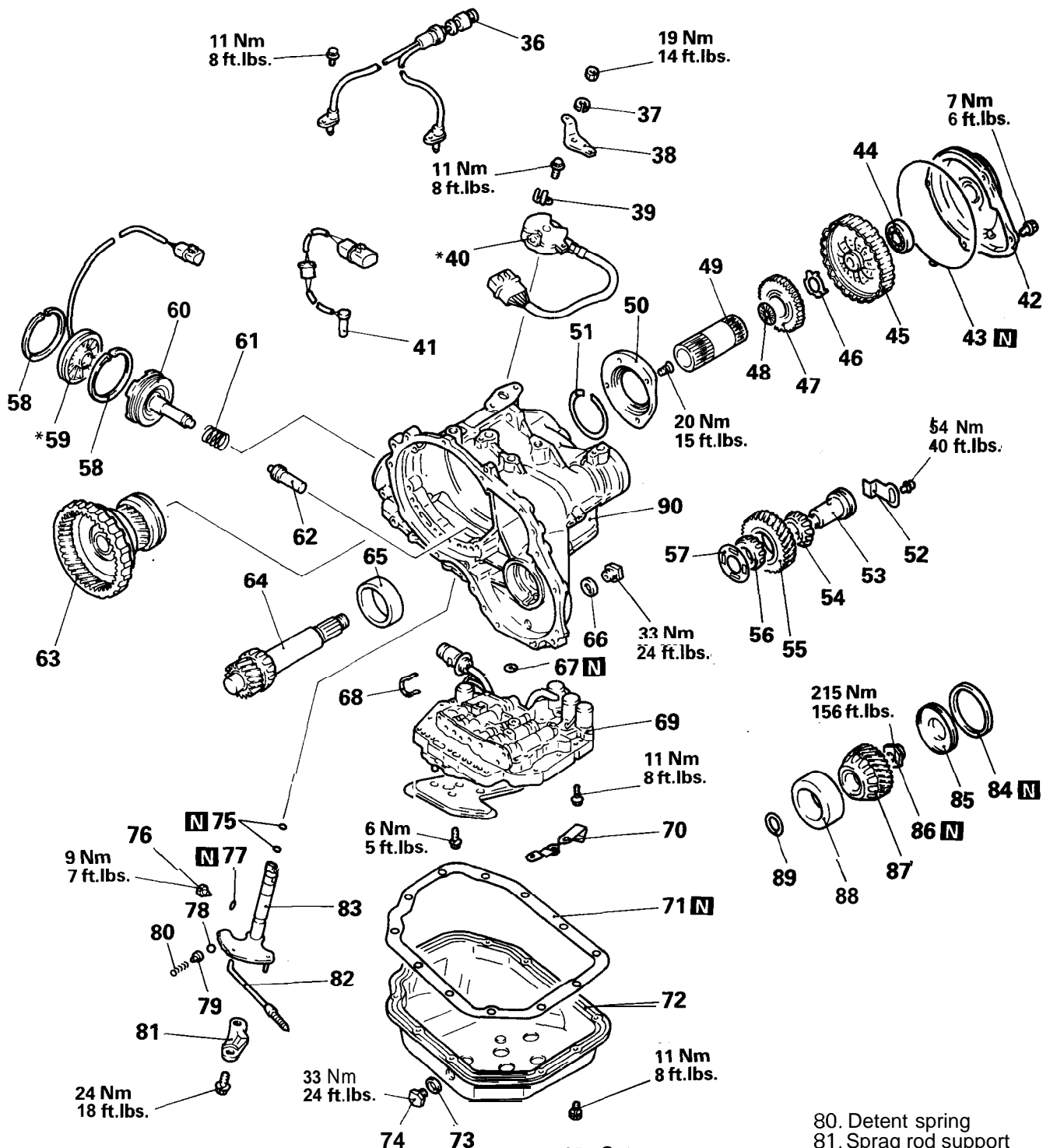

- 36. Pulse generator
- 37. Spring washer
- 38. Control lever
- 39. Clamp
- 40. Park/neutral position switch
- 41. Oil temperature sensor
- 42. End clutch cover
- 43. O-ring
- 44. Bearing
- 45. End clutch
- 46. Thrust washer
- 47. End clutch hub
- 48. Thrust bearing #13
- 49. End clutch shaft

- 50. Bearing retainer
- 51. Snap ring
- 52. Lock plate
- 53. Idler gear shaft
- 54. Bearing inner race
- 55. Idler gear
- 56. Bearing inner race
- 57. Spacer
- 58. Snap ring
- 59. Kickdown servo switch
- 60. Kickdown servo piston
- 61. Spring
- 62. Anchor rod
- 63. Output flange
- 64. Transfer shaft

- 65. Outer race
- 66. Gasket
- 67. O-ring
- 68. Clip (F4A21)
- 69. Valve body
- 70. Clamp
- 71. Gasket
- 72. Oil pan
- 73. Gasket
- 74. Drain plug
- 75. O-ring
- 76. Set screw
- 77. O-ring
- 78. Detent ball
- 79. Detent seat

- 80. Detent spring
- 81. Sprag rod support
- 82. Parking sprag rod
- 83. Control shaft
- 84. D-ring
- 85. Transfer shaft cover
- 86. Lock nut
- 87. Driven gear
- 88. Outer race
- 89. Spacer
- 90. Transmission case

NOTE:
On 1993 and subsequent models, *-marked parts have the connector directly attached, not via a harness.

TFA0051

DISASSEMBLY

- (1) Prior to disassembling the transaxle, plug all openings and thoroughly clean the exterior of the assembly, preferably by steam.
- (2) Place the transmission on the workbench with the oil pan down.
- (3) Remove the torque converter.
- (4) Measuring input shaft end play before disassembly will usually indicate when a thrust washer change is required (except when major parts are replaced). Thrust washers are located between the reaction shaft support and rear clutch retainer, and between the reaction shaft support and front clutch retainer.

Mount a dial indicator to the converter housing using the special tool, with its plunger seated against the end of the input shaft.

Move the input shaft in and out with pliers to obtain the end play reading. Be careful not to scratch the input shaft. Record the indicator reading for reference when reassembling the transaxle.

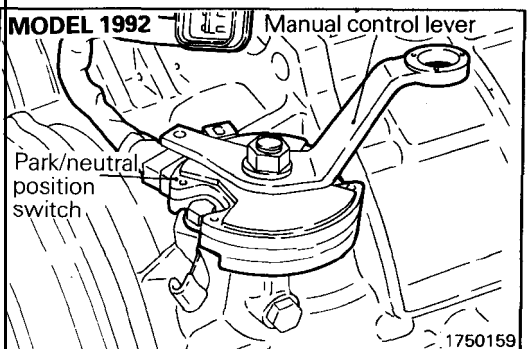
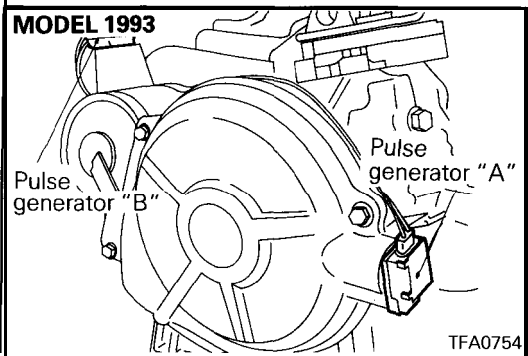
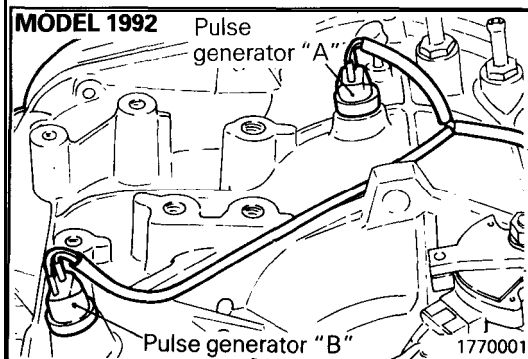
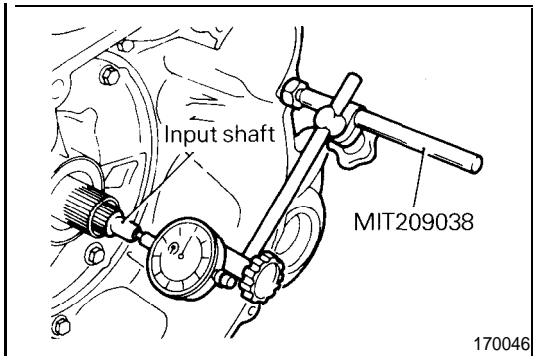

- (5) Remove pulse generators "A" and "B"

- (6) Remove the manual control lever, and then remove the park/neutral position switch.

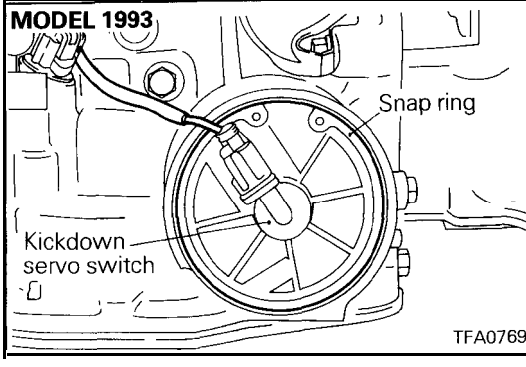
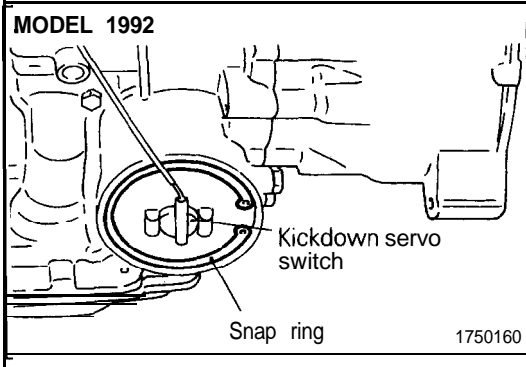
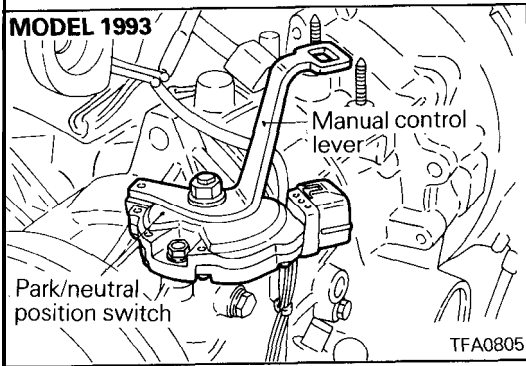

(7) Snap off the snap ring and remove the kickdown servo switch.,

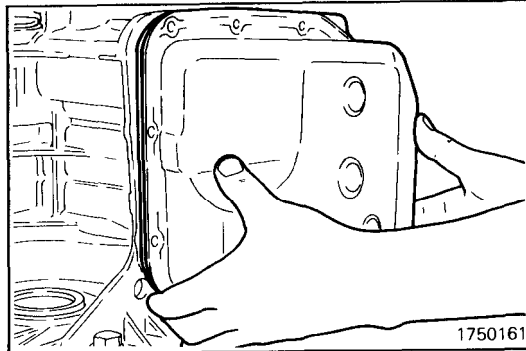

(8) Remove the oil pan and oil pan gasket.

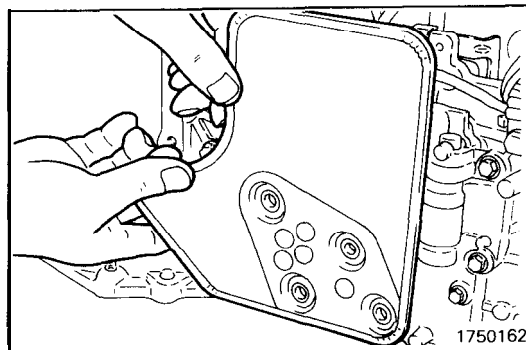

(9) Remove the oil filter.

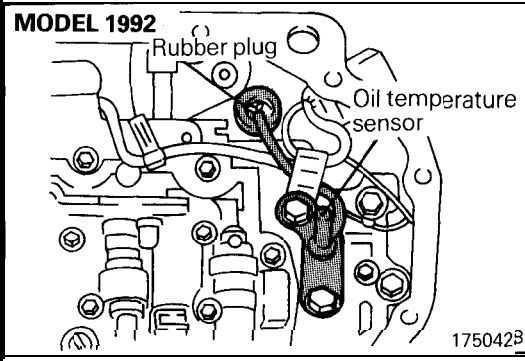

(10) Remove the oil temperature sensor bracket mounting bolts, and remove the oil temperature sensor from its bracket. Using a screwdriver, push out the rubber plug, working from inside the case, and remove the oil temperature sensor from the case.

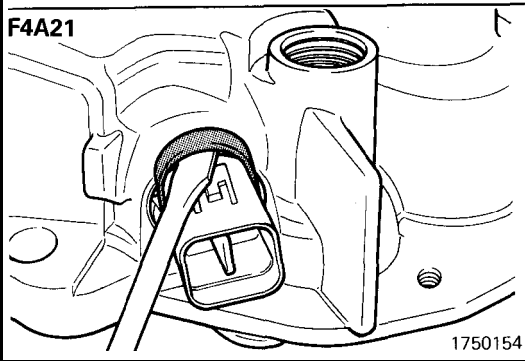
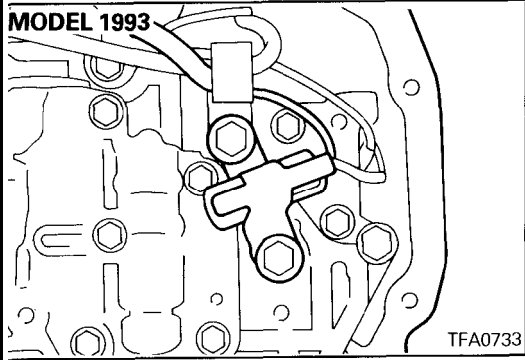

(11) Remove the clip from the solenoid valve connector (F4A21 only).

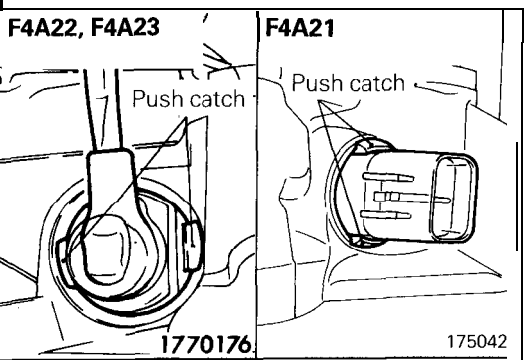

(12) With their catches pressed down, force the harness grommet and connector into the transaxle case.

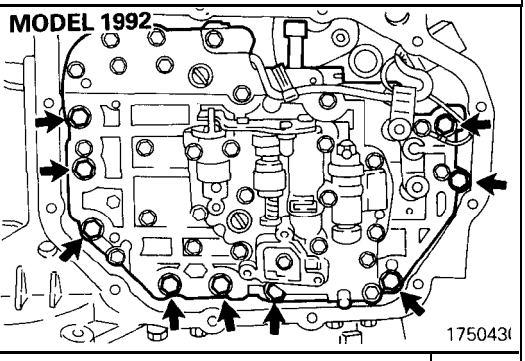

(13) Remove the valve body mounting bolts indicated by arrows and remove the valve body from the transaxle case.

MODEL 1993

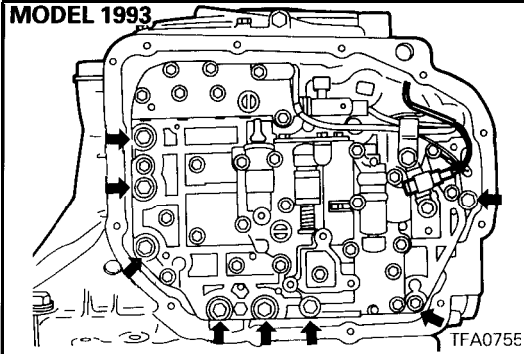

TFA075E

(14) Remove the end clutch cover.

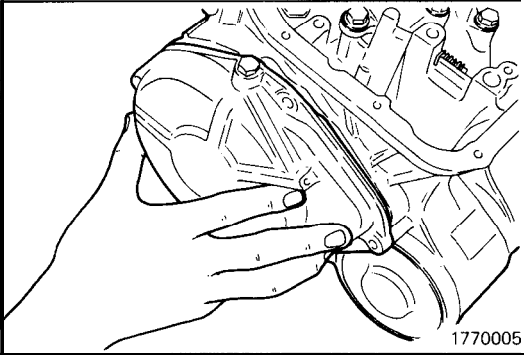

1770005

(15) Remove the end clutch assembly.

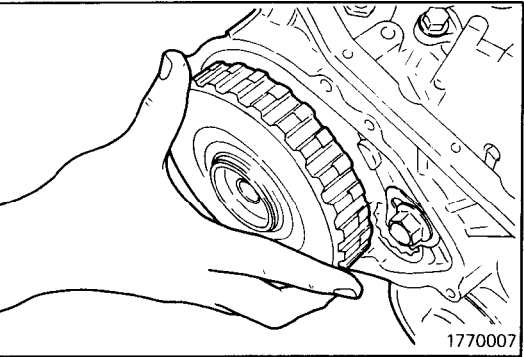

1770007

(16) Remove the thrust washer from the input shaft end.

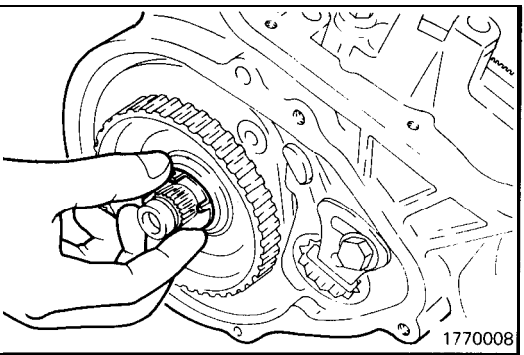

1770008

(17) Remove the end clutch hub and the thrust bearing.

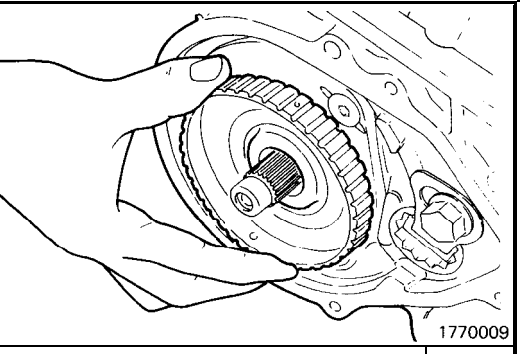

1770009

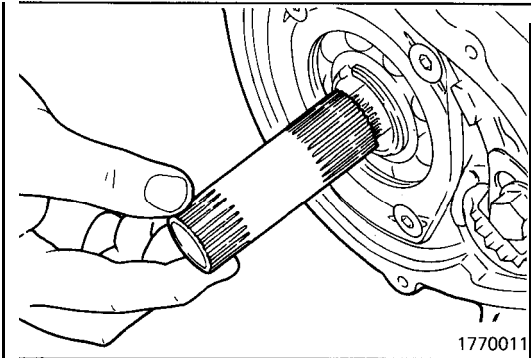

(18) Pull out the end clutch shaft.

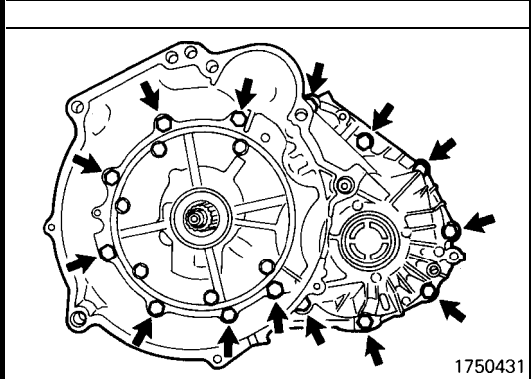

(19) Remove the 14 bolts indicated by arrows and remove the converter housing and gasket.

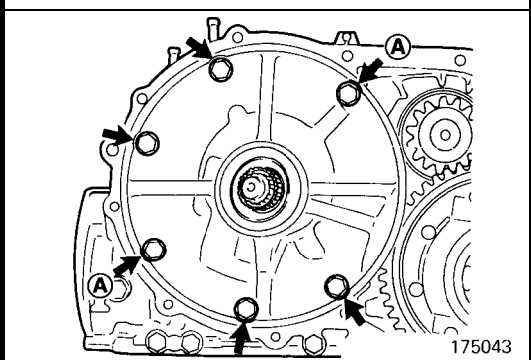

(20) Remove the six oil pump mounting bolts indicated by arrows.

(21) Screw the special tools (MD998333-01) into the bolt holes marked **A**.

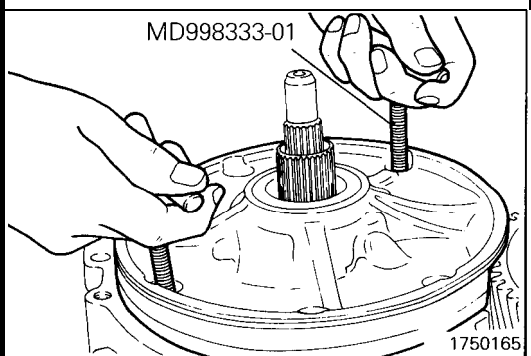

(22) Grasping the special tools, remove the oil pump. Then, remove the gasket.

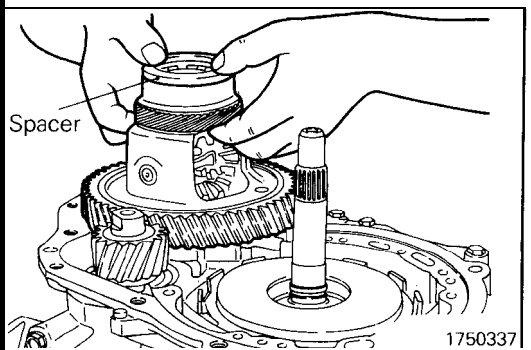

(23) Remove the spacer and differential from the transaxle case.

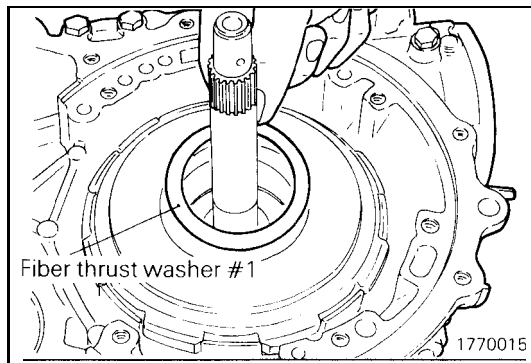

(24) Remove fiber thrust washer #1

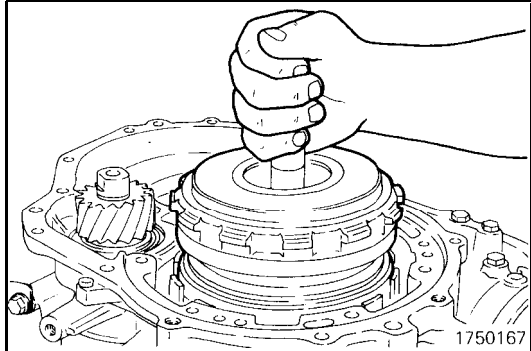

(25) Grasp and raise the input shaft to remove both the front and rear clutch assemblies together.

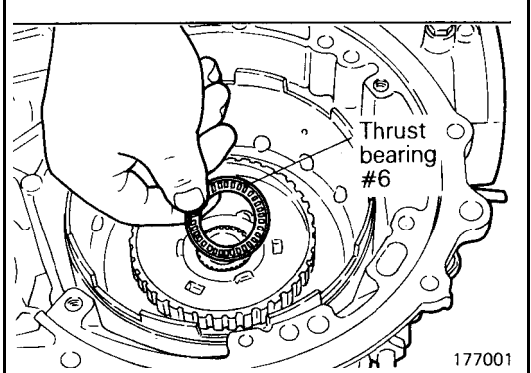

(26) Remove thrust bearing #6.

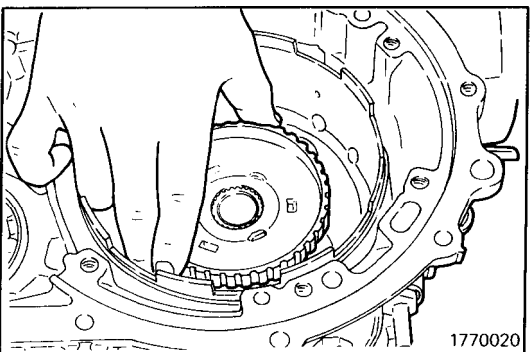

(27) Remove the clutch hub.

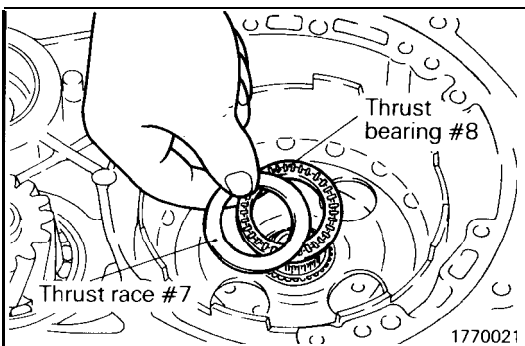

(28) Remove thrust race #7 and thrust bearing #8.

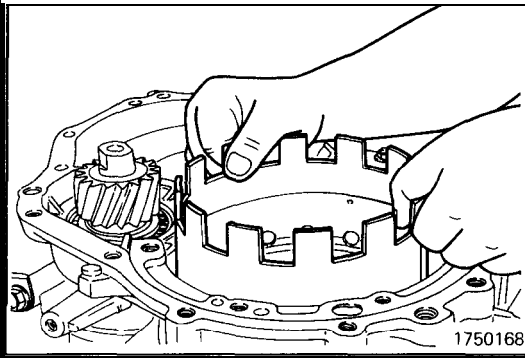

(29) Remove the kickdown drum.

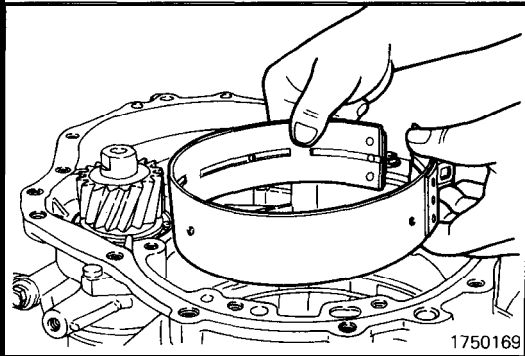

(30) Remove the kickdown band.

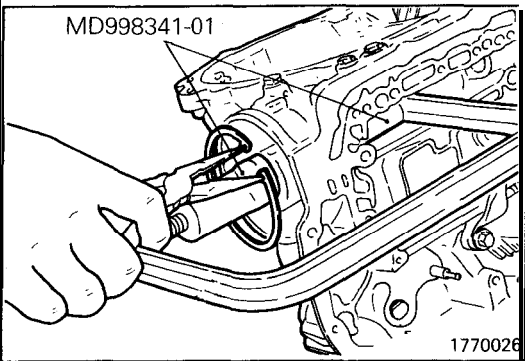

(31) Using the special tools, push in the kickdown servo and remove the snap ring.

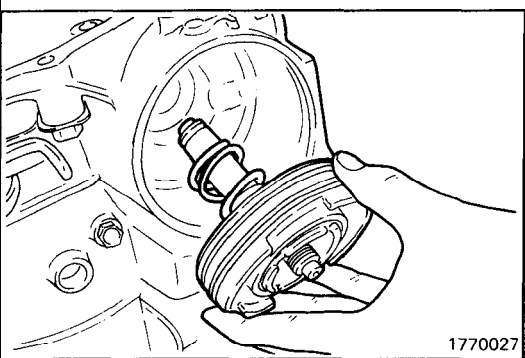

(32) Remove the special tools and then remove the kickdown servo piston, sleeve and spring.

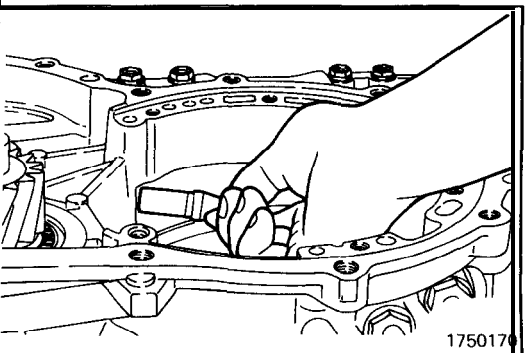

(33) Remove the anchor rod.

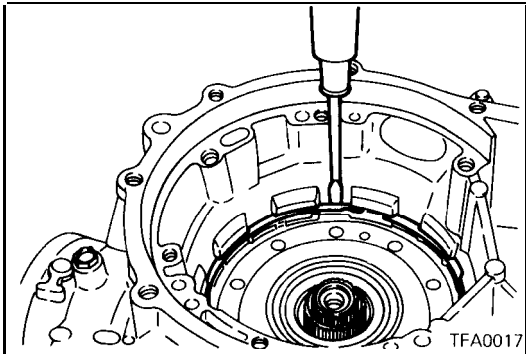

(34) Remove the snap ring.

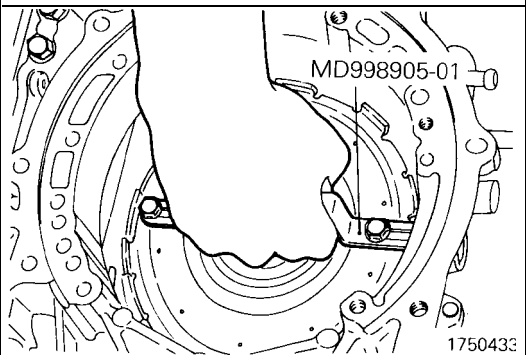

(35) Set the special tool on the center support and remove the center support from the case.

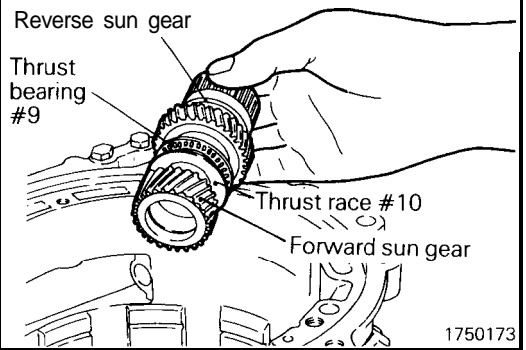

(36) Remove reverse sun gear, thrust bearing #9, thrust race #10 and forward sun gear together.

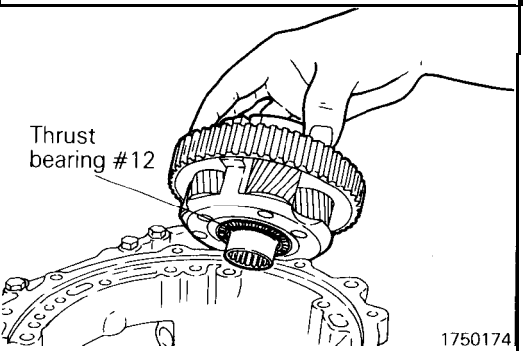

(37) Remove the planetary gear set and thrust bearing #12.

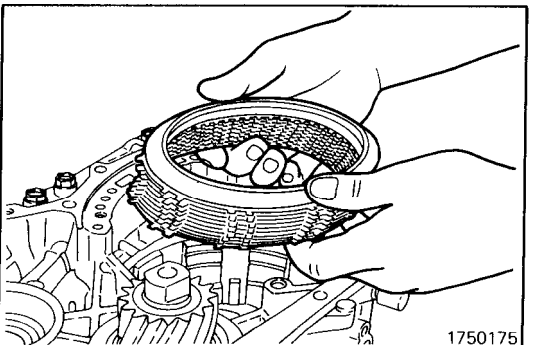

(38) Remove the wave spring, return spring, reaction plate, brake discs, and brake plates.

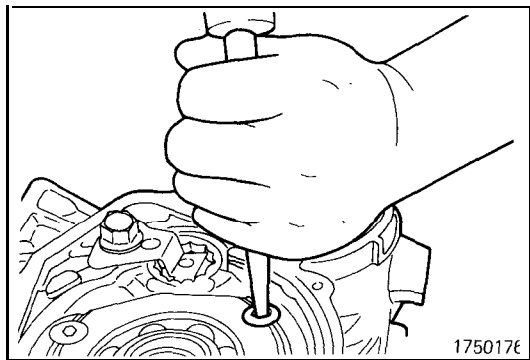

(39) Sealant has been applied to the threads of the screws on the bearing retainer. Tap the screw heads so the screws can be easily loosened.

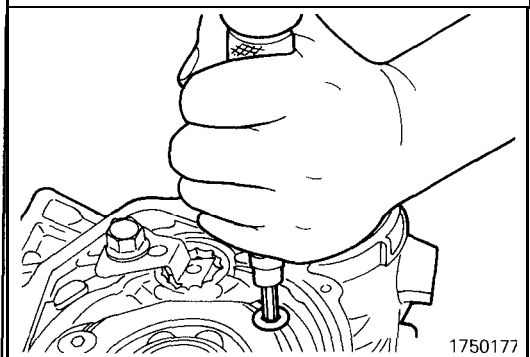

(40) Using an impact driver, loosen the screws and remove the bearing retainer.

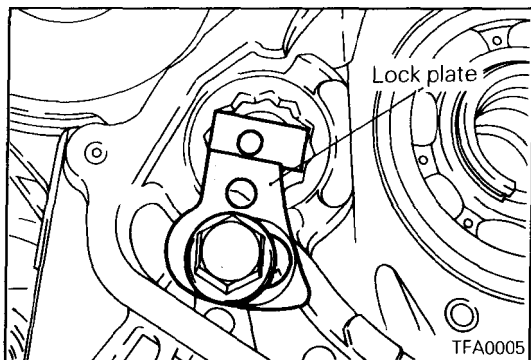

(41) Remove the idler shaft lock plate.

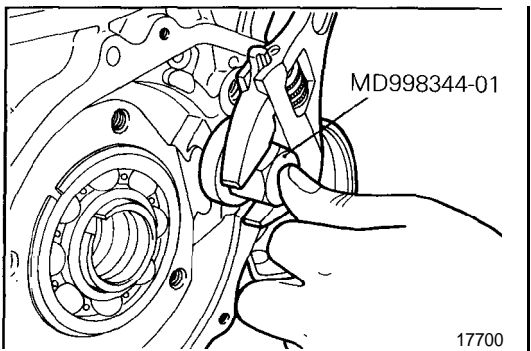

(42) Loosen the transfer idler shaft with the special tool.

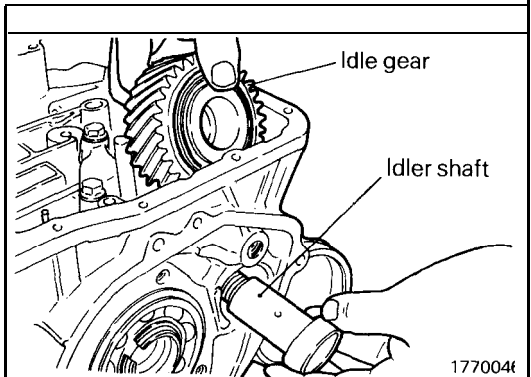

(43) Pull out the transfer idler shaft. Remove the transfer idle gear and the two bearing inner races from inside the case.

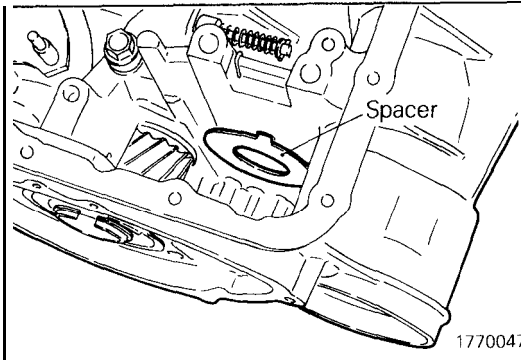

(44) Remove the spacer.

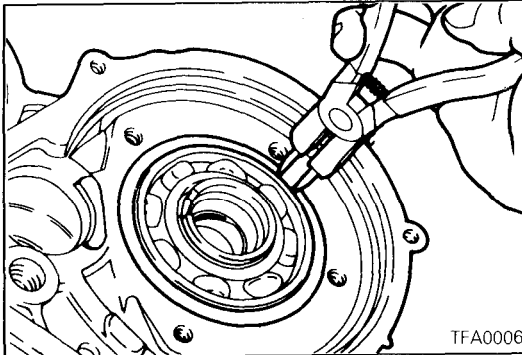

(45) Remove the snap ring from the output flange bearing.

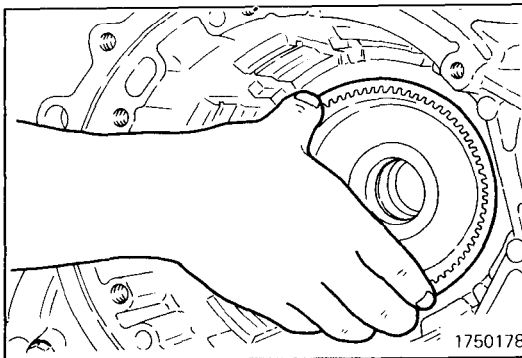

(46) Remove the output flange from the case.

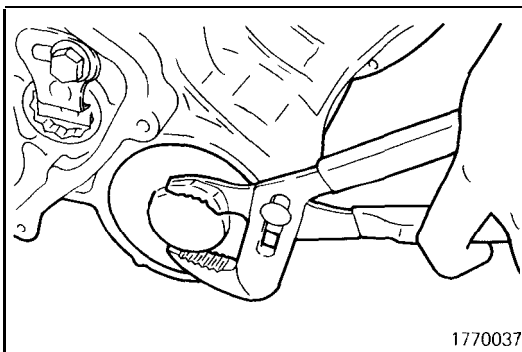

(47) Remove the transfer shaft cover.

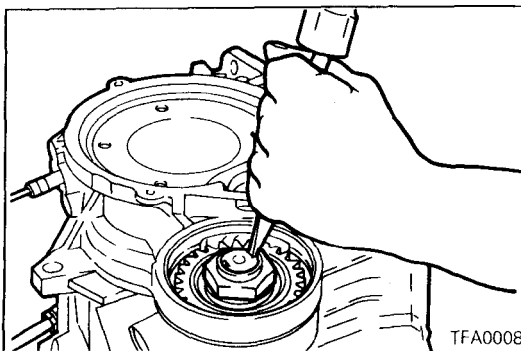

(48) Straighten the locking tab of the transfer shaft lock nut where it is bent.

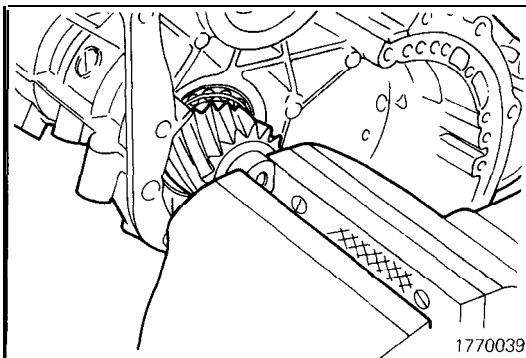

(49)Secure the transfer shaft on the end of the converter housing.

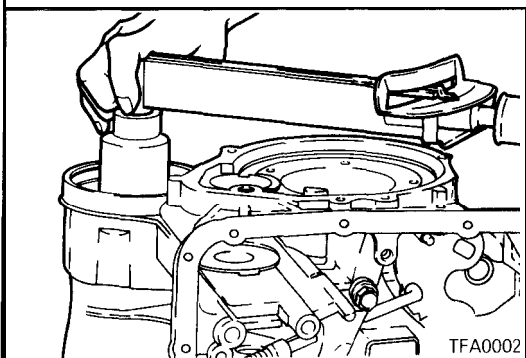

(50)Remove the lock nut.

Caution
The lock nut is a left-handed screw.

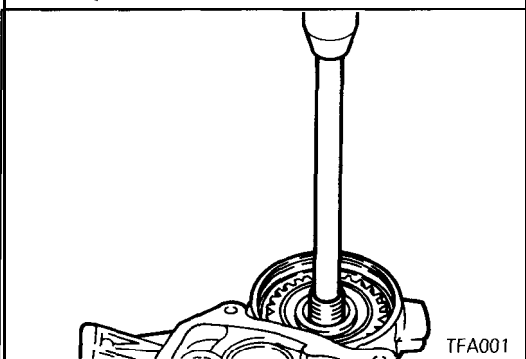

(51)Drive out the transfer shaft toward the converter housing end and remove the transfer shaft and transfer driven gear.

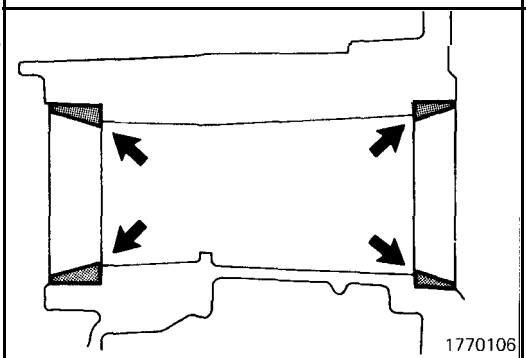

(52)Remove the outer races from the transfer shaft bearing.

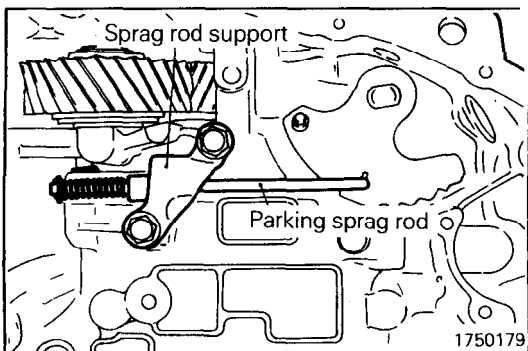

(53)Remove the sprag rod support.

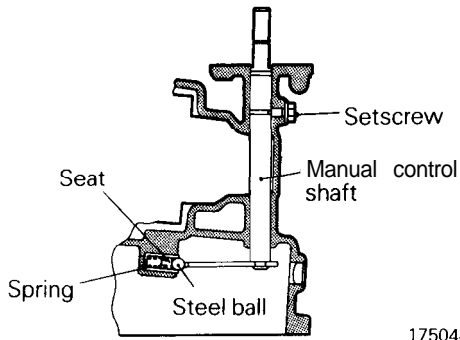

1750441

Pulse generator connector



1-2: Pulse generator "A"
3-4: Pulse generator "B"

1750010



- 1: Pressure control solenoid valve
- 2: Torque converter clutch solenoid
- 3: Shift control solenoid valve "A"
- 4: Shift control solenoid valve "B"

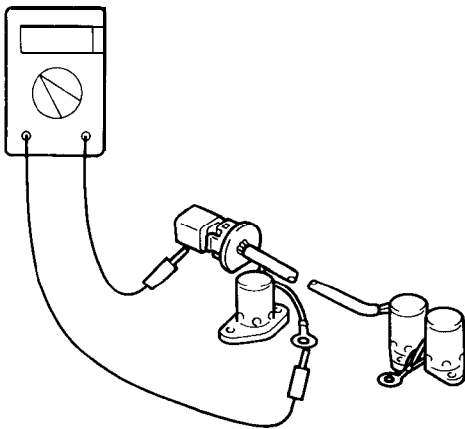

1750426

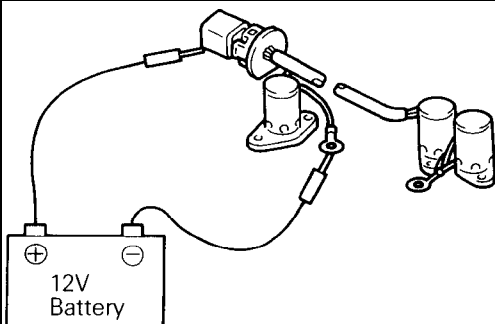

1750427

(54) Remove the set screw, and remove the manual control shaft assembly. At this time, also remove the steel ball, seat and spring.

INSPECTION

PULSE GENERATORS

(1) Measure the resistance between terminals 1 and 2 or 3 and 4.

Standard value: 245 ohm at 20°C (68°F)

(2) A too small resistance indicates a short circuit and a too large resistance indicates an open circuit. In either case, replace the pulse generator assembly.

SOLENOID VALVES

(1) Measure the resistance between the terminals and valve body of each solenoid valve.

Standard value: at 20°C (68°F)

Pressure control solenoid valve **Approx. 3 Ω**

Shift control solenoid valve **Approx. 22 Ω**

Torque converter clutch solenoid

MODEL 1992 and

MODEL 1993 – E33A, D21A, D22A Approx. 13 Ω

MODEL 1993 – CB5A, N11W, N14W, N34W Approx. 3 Ω

(2) A too small or large resistance indicates a short or open circuit.

In either case, replace the solenoid valve assembly.

(3) Connect a 12V battery between the terminal and body of each solenoid valve and check the operating sound.

The valve is okay if an operating sound is heard. No operating sound indicates that the valve is sticking or has accumulated foreign matter. In this case, replace the solenoid valve assembly.

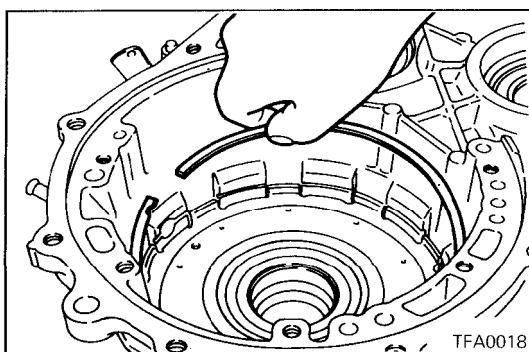
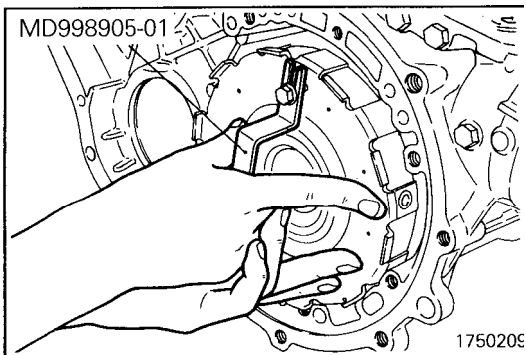
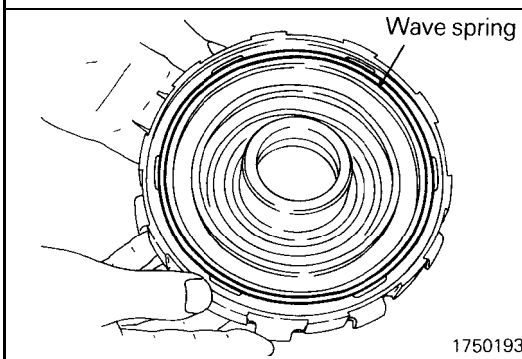
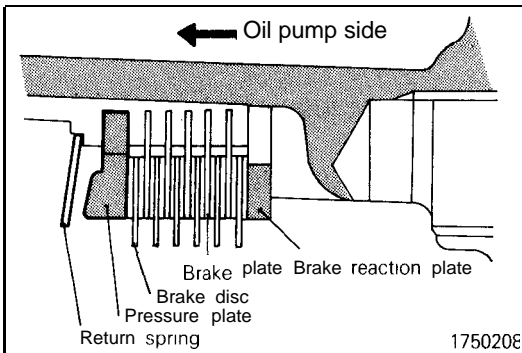
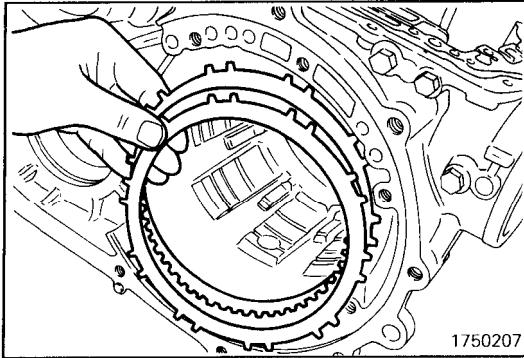

REASSEMBLY

(1) Before reassembling the transaxle, measure the end play in the low-reverse brake and select a pressure plate to obtain the specified end play. Use the following procedure.

(a) Install the brake reaction plate, brake plate, and brake disc in the transaxle case.

Caution

Blow off automatic transmission fluid from the plates and discs with low-pressure compressed air.

(b) Install the appropriate pressure plate and mount the return spring.

Caution

Make sure that the return spring is mounted in the correct direction.

Transaxle model	No. of brake discs	No. of brake plates
F4A21	4	3
F4A22, F4A23	6	5

(c) Apply petrolatum jelly to the wave spring and attach the wave spring on the center support.

(d) Install the two O-rings removed during disassembly and coat them with automatic transmission fluid.

(e) Attach the special tool to the center support and install the support in the transaxle case.

Caution

1. Install the center support, taking care that the waved spring is not out of position.

2. Install the two O-rings in alignment with the oil holes provided in the transaxle case.

(f) Remove the special tool.

(g) Install the snap ring.

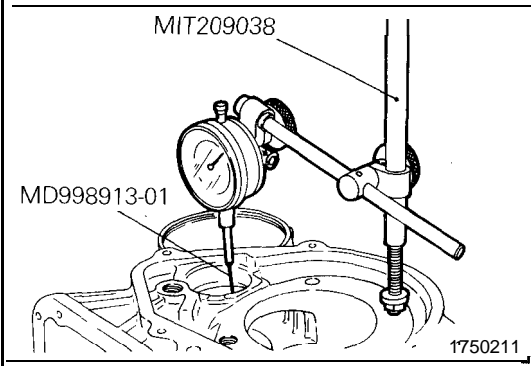

- (h) Mount the special tool and dial indicator on the rear side of the transaxle case. Make sure that the dial indicator rod (MD998913-01) is inserted into the transfer idler shaft hole, contacting the brake reaction plate at a right angle.

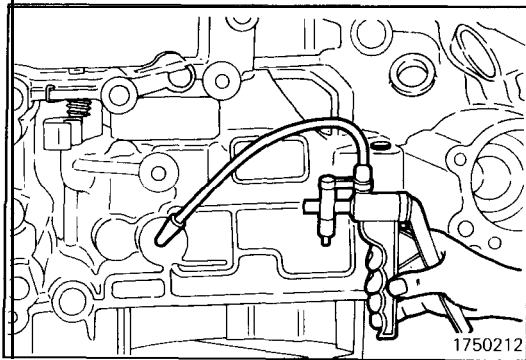
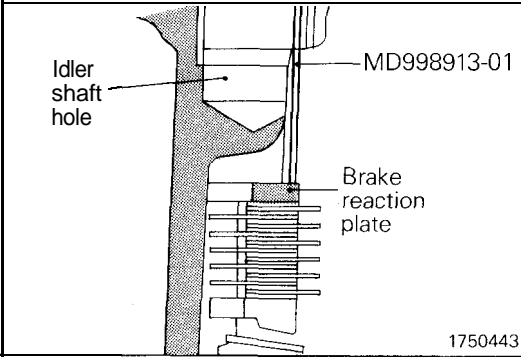

- (i) Using a hand pump, feed air through the location shown and, at the same time, read the dial indicator and select a pressure plate to obtain the specified end play.

Standard value:

F4A21	0.7 – 0.9 mm (.028 – .035 in.)
F4A22, F4A23	1.0 – 1.2 mm (.039 – .047 in.)

- (j) After a pressure plate of the appropriate thickness has been selected, remove all the mounted parts.

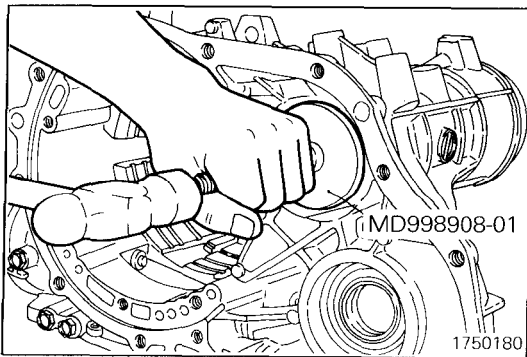

- (2) Using the special tools, drive the transfer shaft bearing outer races into position.

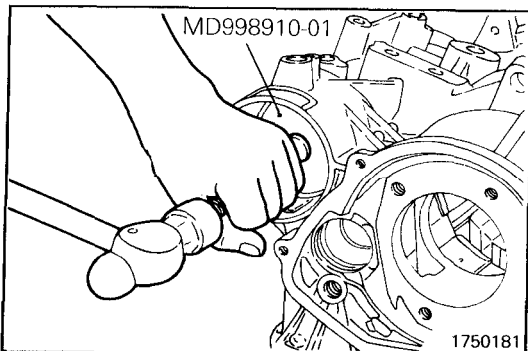

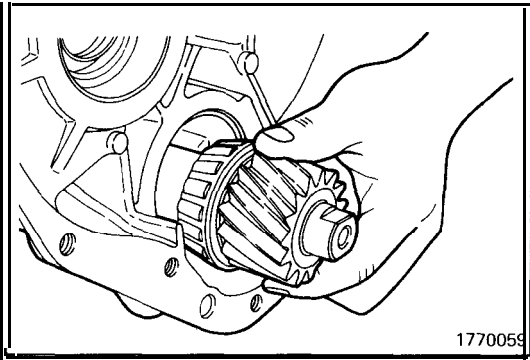

(3) Insert the transfer shaft in the case.

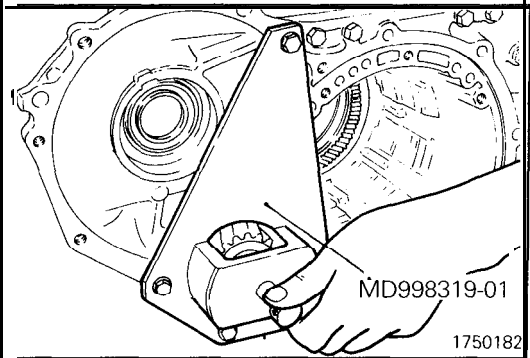

(4) Mount the special tool on the transaxle case to support the transfer shaft.

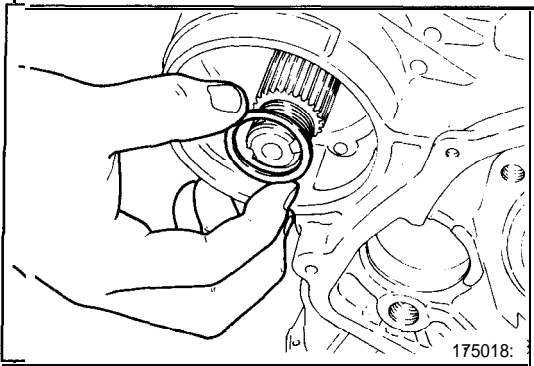

(5) Install the thickest spacer [1.80 mm (.071 in.)].

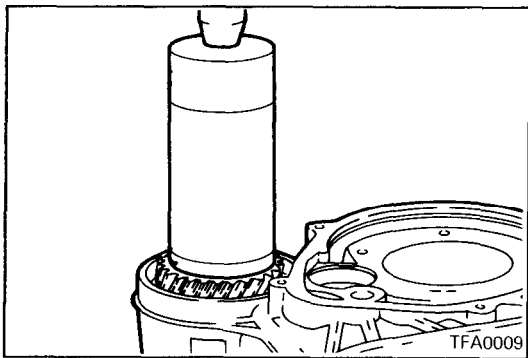

(6) Install the transfer driven gear on the transfer shaft

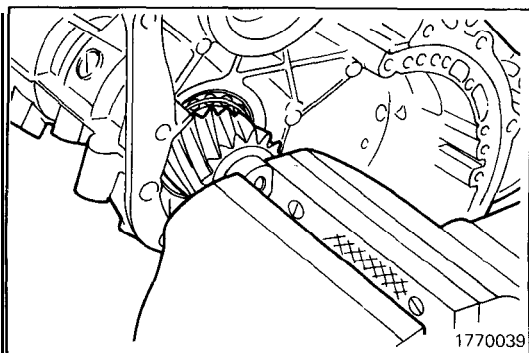

(7) Remove the special tool and secure the transfer shaft in position.

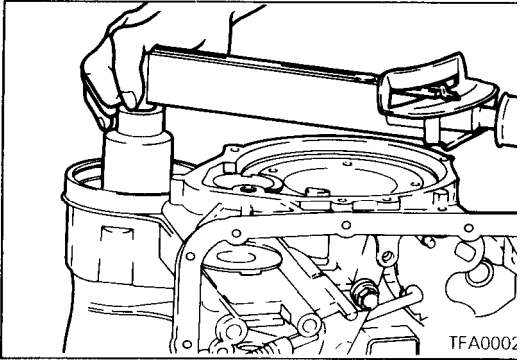

- (8) Put on the lock nut and tighten it to specified torque.

Caution

The lock nut is a left-handed screw.

Tightening torque: 215 Nm (156 ft.lbs.)

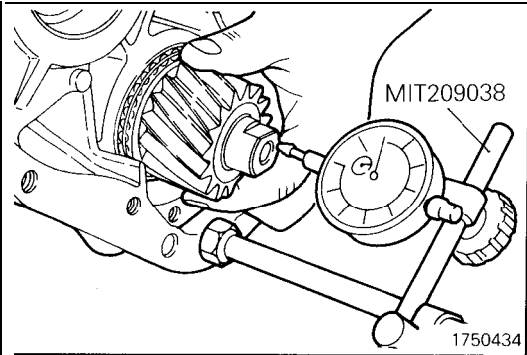

- (9) Measure the end play while sliding the transfer shaft in and out, and select a spacer to obtain the specified end play.

Standard value: 0 – 0.025 mm (0 – .001 in.)

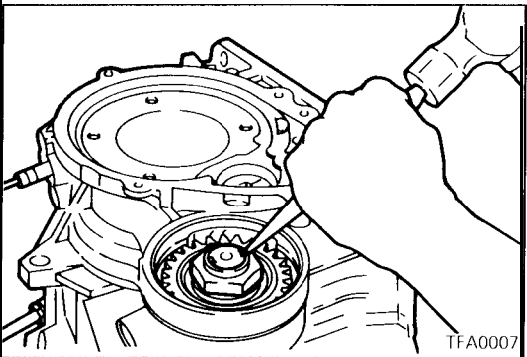

- (10) Bend the locking tab of the lock nut.

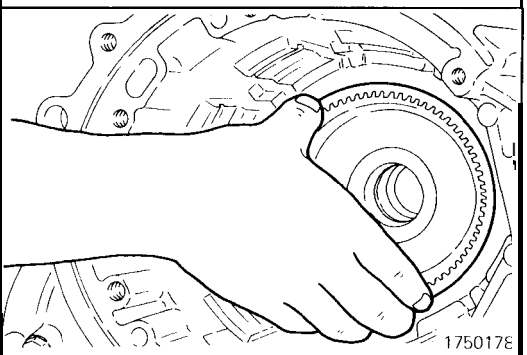

- (11) Place the transmission case on the workbench with the oil pan mounting surface up.

- (12) Insert the output flange in position (with two ball bearings and transfer drive gear attached) from the inside of the transaxle case.

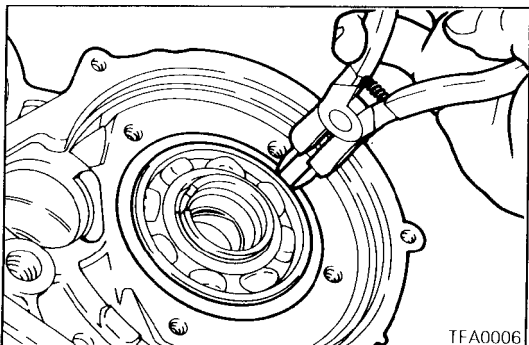

- (13) Install the snap ring in the groove of the output flange bearing.

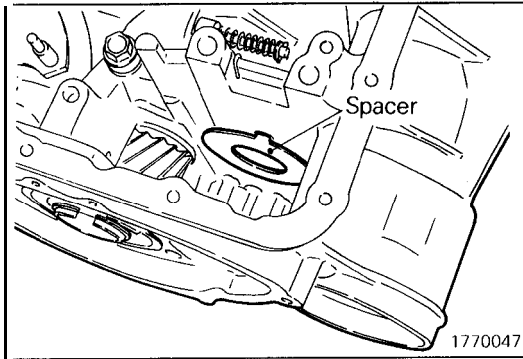

(14) Apply petrolatum jelly to the spacer and attach the spacer to the case.

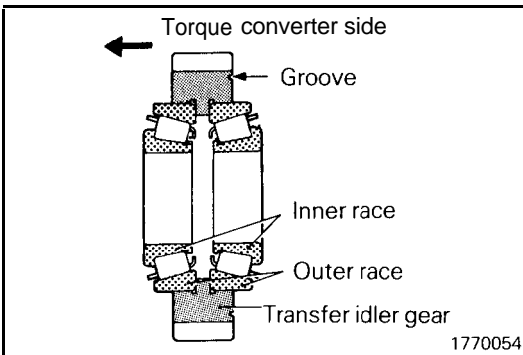

(15) Install the bearing outer race and inner races in the transfer idler gear.

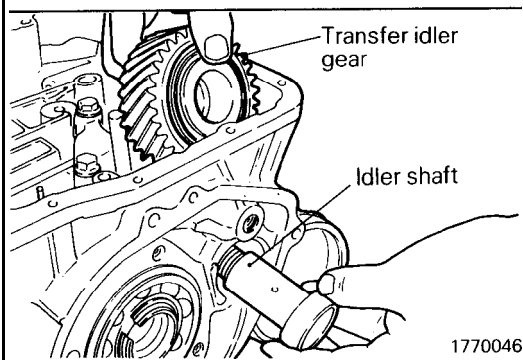

(16) Place the transfer idler gear in the case, and insert and screw the idler shaft into position.

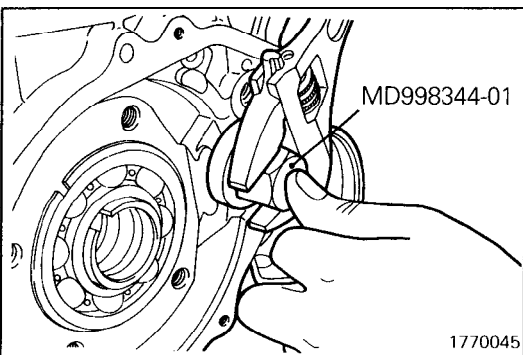

(17) Screw in and tighten the idler shaft by using the special tool.

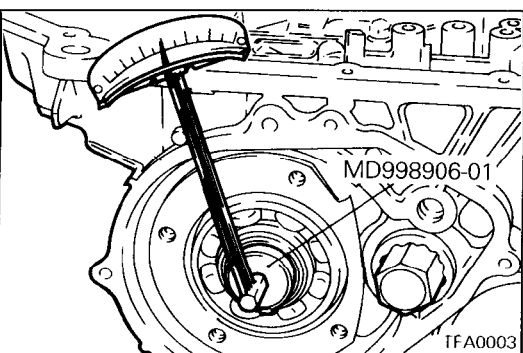

(18) Insert the special tool into the output flange and measure the preload using a low reading torque wrench. Adjust the preload to the standard value by tightening or loosening the transfer idler shaft.

Standard value:
F4A21, F4A22
F4A23

0.8 Nm (.6 ft.lbs.)
1.5 Nm (1.1 ft.lbs.)

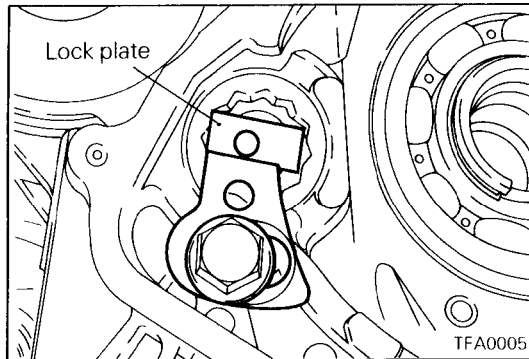

(19) After completing the preload adjustment, install the idler shaft lock plate. The clearance between the idler shaft and the lock plate should be closed in the direction that will prevent idler shaft looseness, and then tighten the lock plate bolt to the specified torque.

Tightening torque: 54 Nm (40 ft.lbs.)

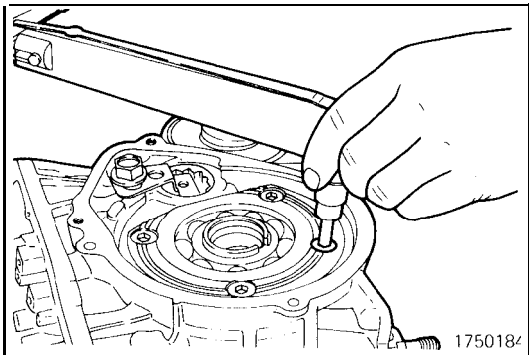

(20) Install the bearing retainer.

(21) Tighten the screw to specified torque.

Caution

The screw should not be reused.

Tightening torque: 20 Nm (15 ft.lbs.)

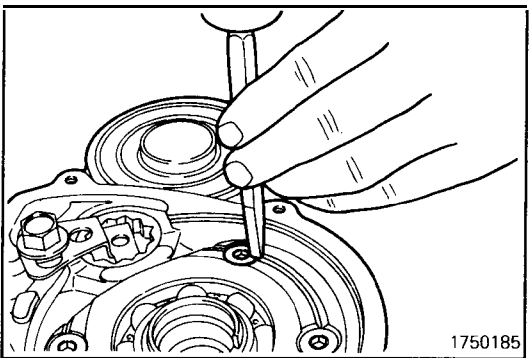

(22) Lock the screw head in place using a chisel.

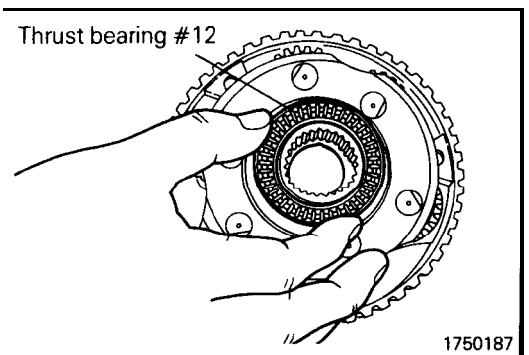

(23) Apply petrolatum jelly to thrust bearing #12 and secure the bearing on the planetary carrier.

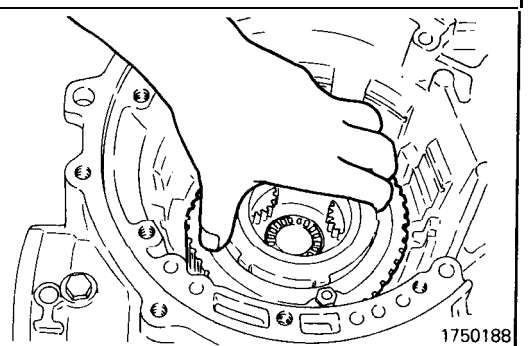

(24) Mount the planetary carrier on the case.

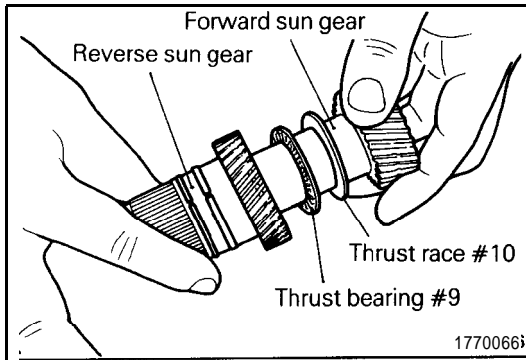

(25) Attach thrust race #10 and thrust bearing #9 to the forward sun gear. Then, assemble the reverse sun gear.

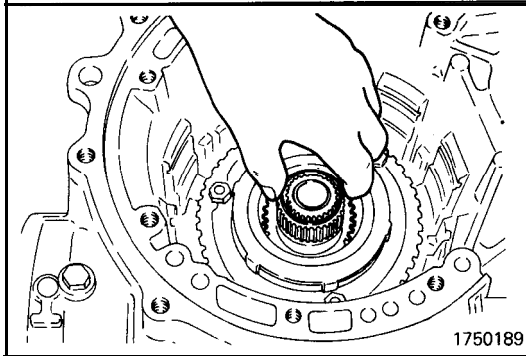

(26) Install the sun gear assembly assembled in step (25) in the planetary carrier.

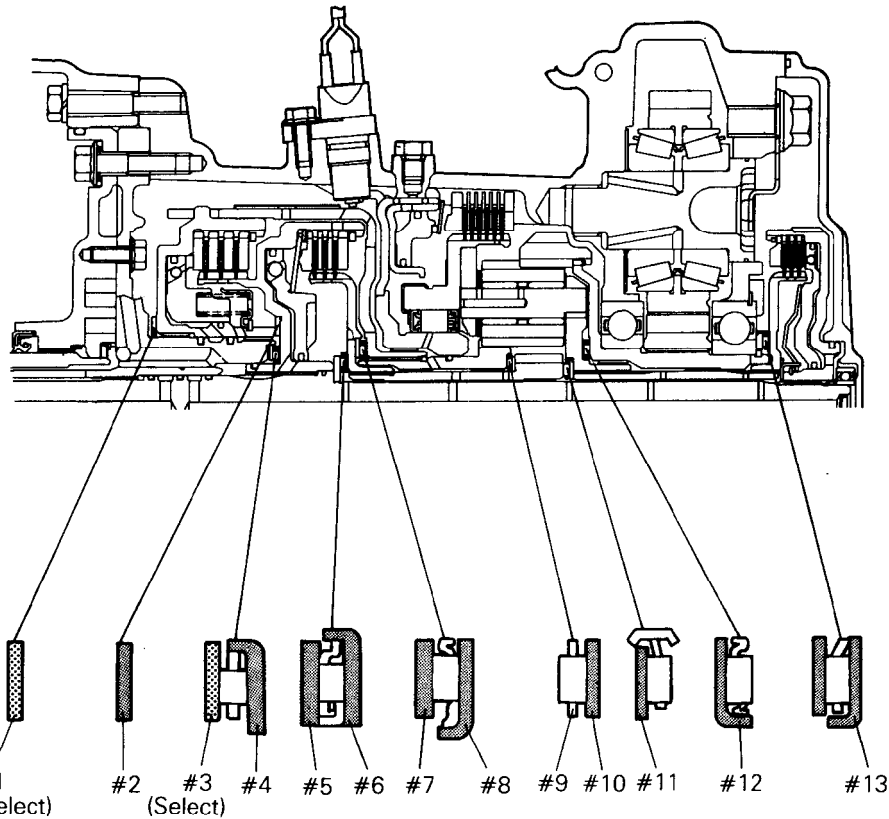

1750186

IDENTIFICATION OF THRUST BEARINGS, THRUST RACES, AND THRUST WASHERS

mm (in.)

O.D.	I.D.	Thickness	Part No.	Identification marking	O.D.	I.D.	Thickness	Part No.	Identification marking
70 (2.756)	55.7 (2.193)	1.4 (.055)	*1	#1	48.1 (1.906)	34.4 (1.354)		MD707271	#4
70 (2.756)	55.7 (2.193)	1.8 (.071)	*2		40 (1.575)	21 (.827)	2.4 (.094)	MD722552 (F4A21, F4A22)	#5
70 (2.756)	55.7 (2.193)	2.2 (.087)	*3		40 (1.575)	21 (.827)	1.8 (.071)	MD720751 (F4A23)	#5
70 (2.756)	55.7 (2.193)	2.6 (.102)	*4		42.6 (1.677)	28 (1.102)		MD720753	#6
70 (2.756)	55.7 (2.193)	1.8 (.071)	MD707290 (F4A21) MD729336 (F4A22, F4A23)	#2	54 (2.126)	38.7 (1.524)	1.6 (.063)	MD704936	#7
48.9 (1.925)	37 (1.457)	1.0 (.039)	MD997854 (incl *1)		#3	52 (2.047)	36.4 (1.433)		MD720010
48.9 (1.925)	37 (1.457)	1.2 (.047)	MD997847 (incl *1)	41 (1.614)		28 (1.102)	–	MD728763	#9
48.9 (1.925)	37 (1.457)	1.4 (.055)	MD997848 (incl ● 2)	39 (1.535)		28 (1.102)	1.2 (.047)	MD728764	#10
48.9 (1.925)	37 (1.457)	1.6 (.063)	MD997849 (incl.*2)	38 (1.496)		22.2 (0.874)	–	MD727787 (F4A21, F4A22)	#11
48.9 (1.925)	37 (1.457)	1.8 (.071)	MD997850 (incl.*3)	42.4 (1.669)		22.2 (0.874)	–	MD722797 (F4A23)	#11
48.9 (1.925)	37 (1.457)	2.0 (.079)	MD997851 (incl.*3)	52 (2.047)		36.4 (1.433)	–	MD720010 (F4A21, F4A22)	#12
48.9 (1.925)	37 (1.457)	2.2 (.087)	MD997852 (incl.*4)	54 (2.126)		36.4 (1.433)	–	MD/19846 (F4A23)	#12
48.9 (1.925)	37 (1.457)	2.4 (.094)	MD997853 (incl.*4)	58 (2.283)		44 (1.732)	–	MD724206	#13

TSB Revision

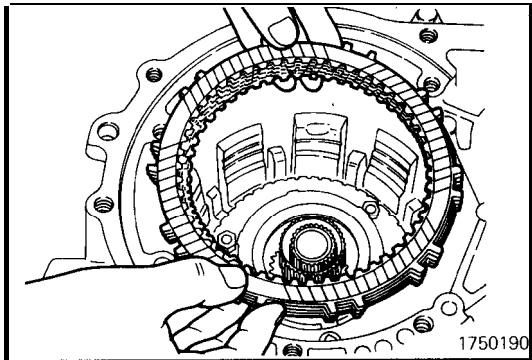

(27) Put the brake disc and brake plate in position.

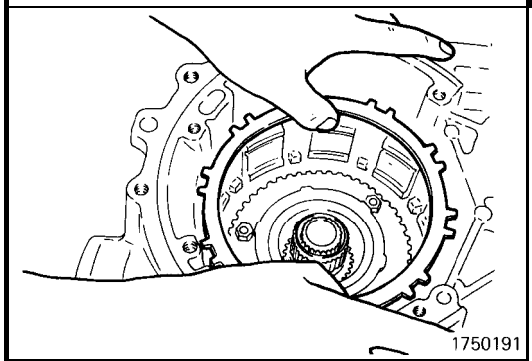
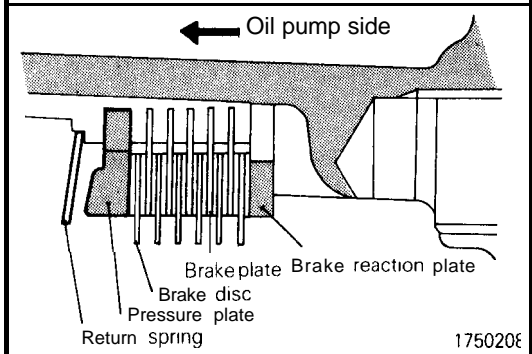

(28) Install the pressure plate which was selected in Step (1).

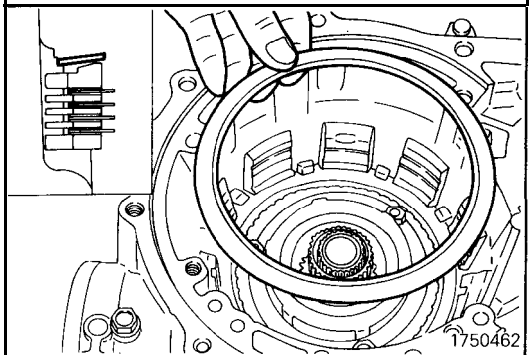

(29) Install the return spring.

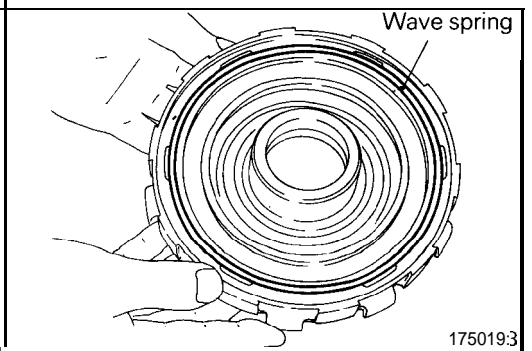

(30) Apply petrolatum jelly to the wave spring and attach the wave spring to the center support.

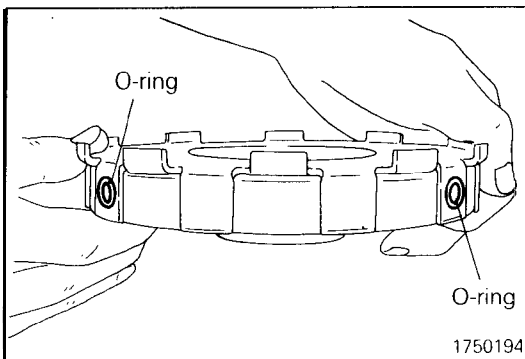

- (31) Install the two new O-rings on the hydraulic pressure holes of the center support.
Apply automatic transmission fluid to the O-rings.

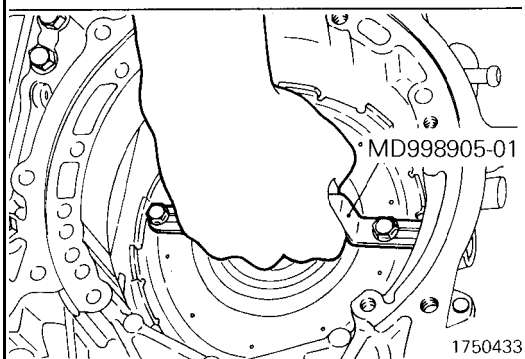

- (32) Attach the special tool to the center support. Install the center support slowly in the transaxle case, grasping the special tool.

Caution

1. During installation, take care not to let the wave spring drop which was applied in Step (30).
2. Install the two O-rings in alignment with the oil holes provided in the transaxle case.

- (33) Remove the special tool from the center support.

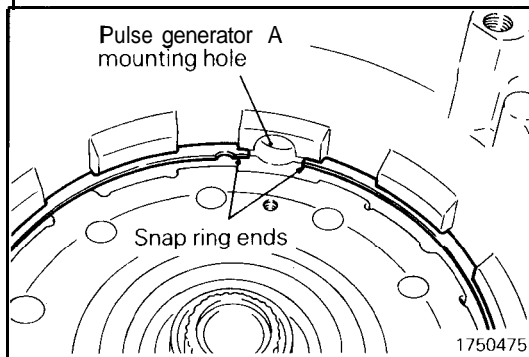

- (34) Install the snap ring to secure the center support. The snap ring ends should not interfere with the pulse generator mounting hole.

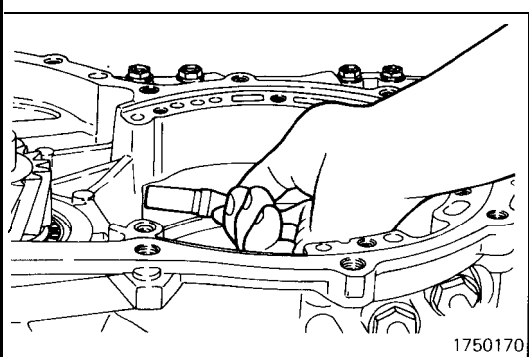

- (35) Install the anchor rod, in the transaxle case.

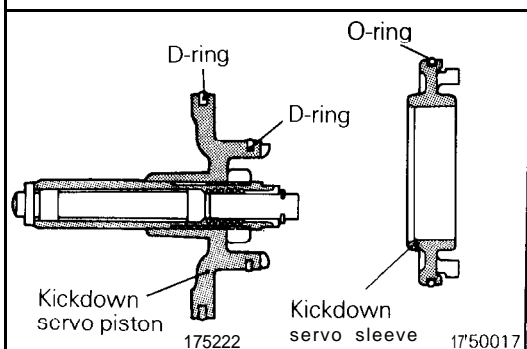

- (36) Install a new teflon seal ring and a new D-ring in the grooves of the kickdown servo piston, and apply automatic transaxle fluid to the rings.

- (37) Install a new O-ring to the groove of kickdown servo sleeve, and apply automatic transaxle fluid to the ring.

- (38) Assemble the kickdown servo piston with the sleeve.

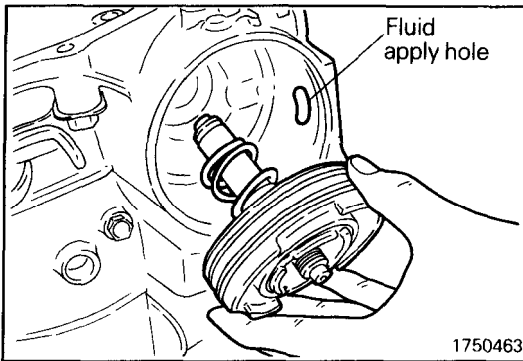

(39) Put the spring on the kickdown servo piston and sleeve assembly, and insert them together in the transaxle case, making sure that the end gap of the teflon seal ring of the kickdown servo piston does not interfere with the fluid apply hole provided in the servo bore of the transaxle case:

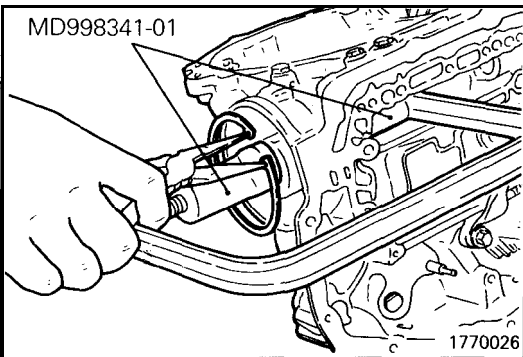

(40) Using the special tools, push in the kickdown servo piston and sleeve assembly, and then install the snap ring.

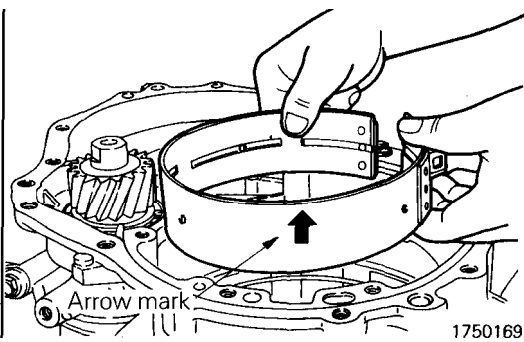

(41) Install the kickdown band; attach the ends of the band to the ends of the anchor rod and servo piston rod.

NOTE

Install the band with the arrow mark forward oil pump side (F4A23).

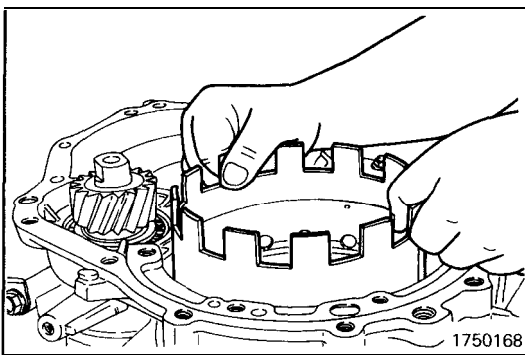

(42) When putting the kickdown drum in the kickdown band, engage the splines of the kickdown drum with those of the reverse sun gear. Place the kickdown band on the kickdown drum and tighten the kickdown servo adjusting screw to keep the band in position.

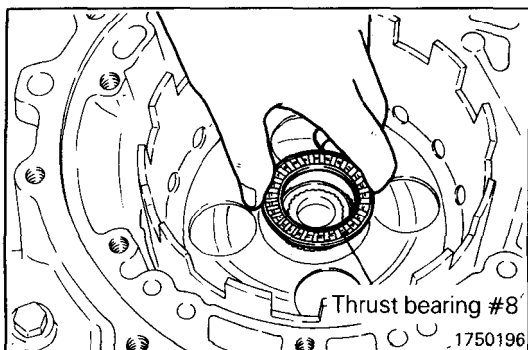

(43) Apply petrolatum jelly to thrust bearing #8 and attach the thrust bearing to the kickdown drum.

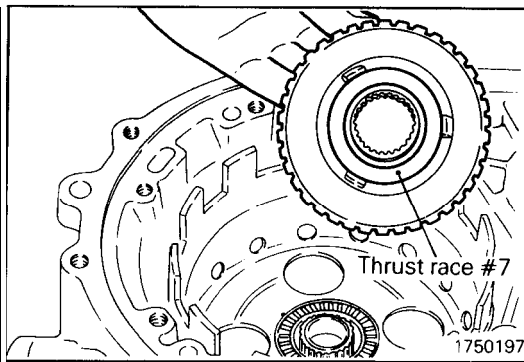

(44) Apply petrolatum jelly to thrust race #7 and attach the thrust race to the rear clutch hub.

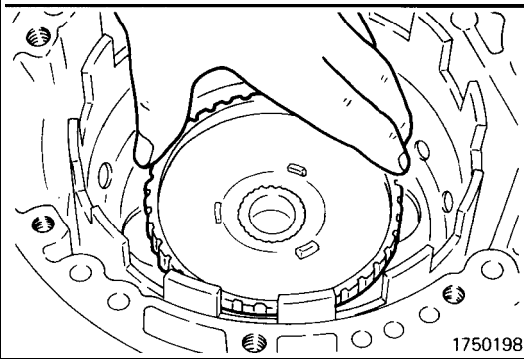

(45) Install clutch hub, engaging it with the forward sun gear splines.

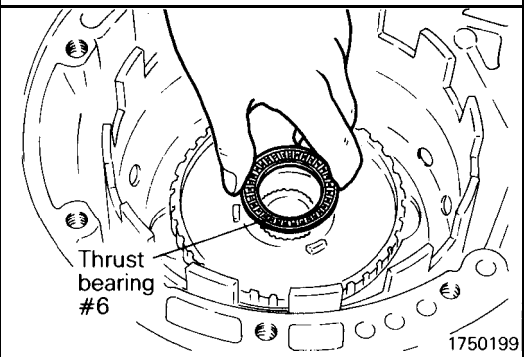

(46) Apply petrolatum jelly to thrust bearing #6 and attach it to the clutch hub.

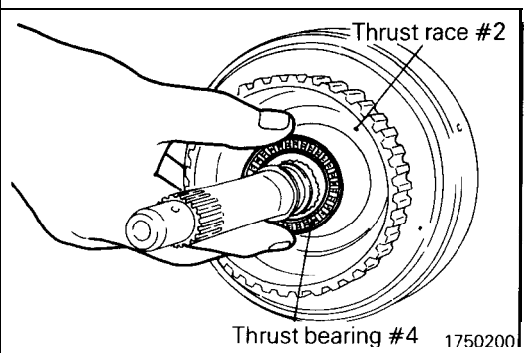

(47) Apply petrolatum jelly to thrust washer #2 and thrust bearing #4 and attach the washer and bearing to the rear clutch assembly.

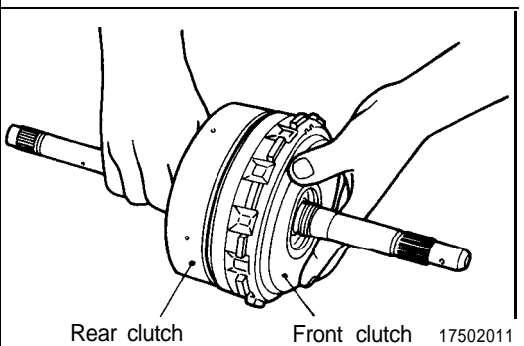

(48) Mate the rear clutch assembly with the front clutch assembly.

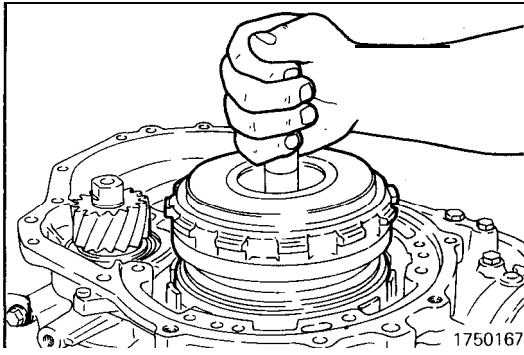

(49) Install the clutch assembly.

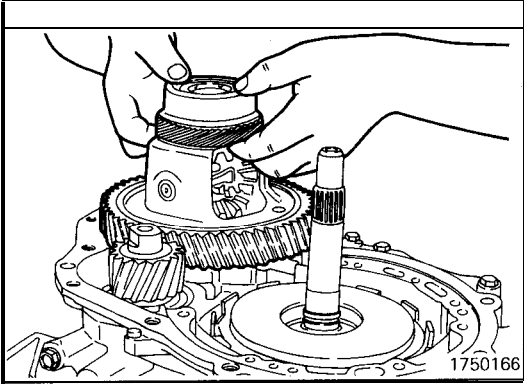

(50) Install the differential.

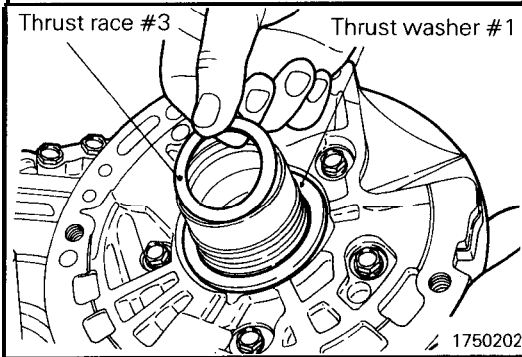

(51) Attach thrust race #3 and thrust washer #1 on the rear end face of the oil pump with petrolatum jelly.

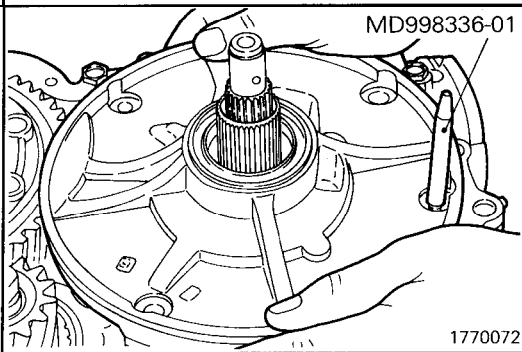

(52) Install the special tool on the transaxle case. Using the special tool as a guide, install a new oil pump gasket and the oil pump in the case.

(53) Remove the special tool.

(54) Tighten the oil pump bolts to the specified torque.

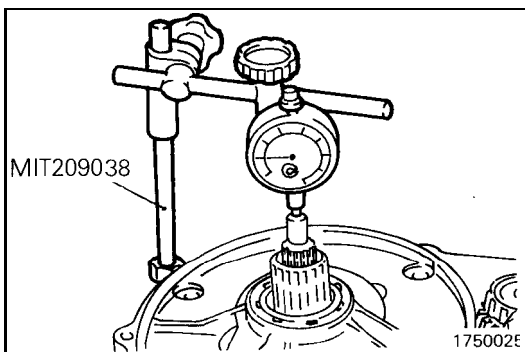

(55) Measure the end play of the input shaft. If the measurement is out of specification, replace thrust race #3 and thrust washer #1 to meet the specification.

Standard value: 0.3 – 1.0 mm (.012 – .039 in.)

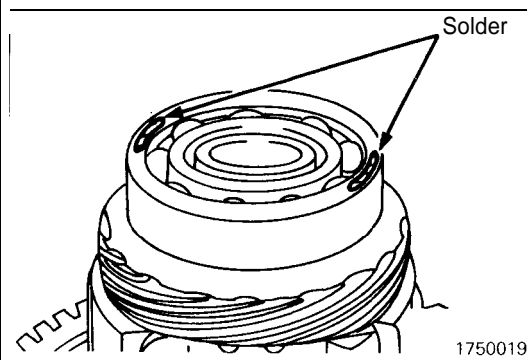

(56) Place approx. 10 mm (.394 in.) long and 2.5 mm (.10 in.) dia. pieces of solder at the locations shown on the differential assembly.

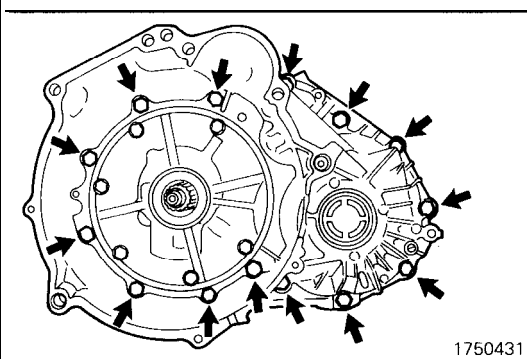

(57) Install the converter housing directly to the transmission case without installing the rubber coated metal gasket.
 (58) Tighten the bolts to the specification.
 (59) Loosen the bolts and remove the converter housing and remove the pieces of flattened solder.

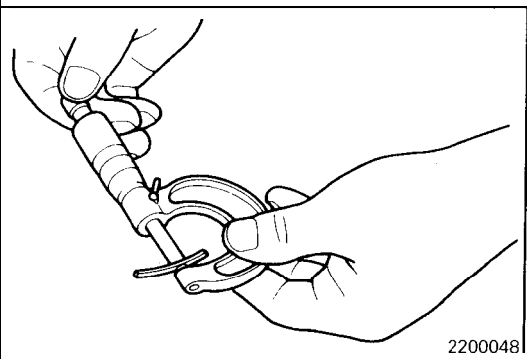

(60) Measure the thickness of the flattened solder using a micrometer. Add the measured solder thickness (T) to the value 0.38 mm (.015 in.), which corresponds to the gasket thickness.

Then subtract from that sum a value corresponding to the specified end play.

The result obtained is the thickness of the spacer to be selected.

Select a spacer whose thickness falls within the range determined by the formulas below:

$$[T + 0.38 \text{ mm } (.015 \text{ in.}) - 0.15 \text{ mm } (.006 \text{ in.})] \text{ to } [T + 0.38 \text{ mm } (.015 \text{ in.}) - 0 \text{ mm } (0 \text{ in.})]$$

(61) Place the spacer which was selected in Step (60) on the outer race of the differential bearing.

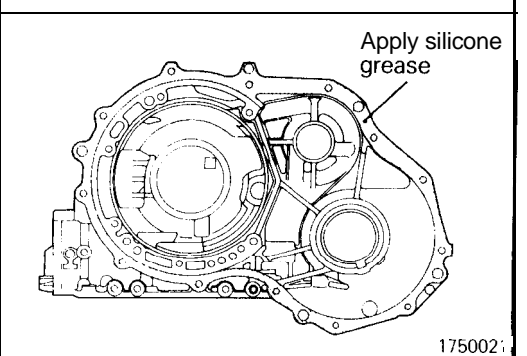
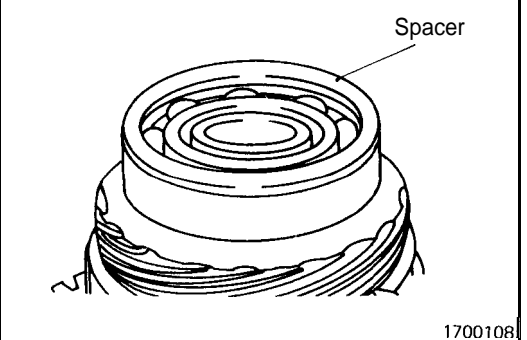

(62) Apply silicone grease to all gasket surfaces of the transaxle case.

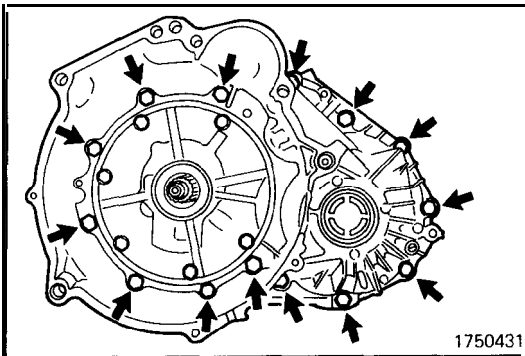

(63) Install a new gasket on the transaxle case.

Caution

Do not reuse the gasket which was previously removed.

(64) Install converter housing and tighten the 14 bolts indicated by arrows to specified torque.

Tightening torque: 21 Nm (16 ft.lbs.)

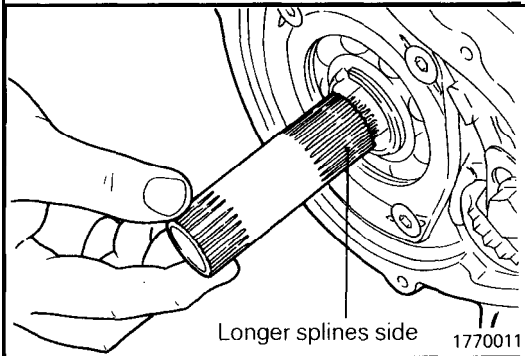

(65) Install the end clutch shaft, inserting the end that has the longer splines first.

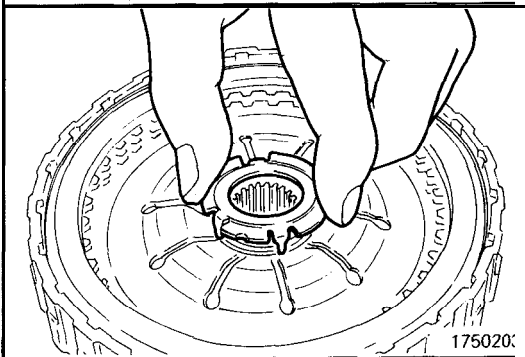

(66) Install the thrust washer on the return spring at the end clutch side.

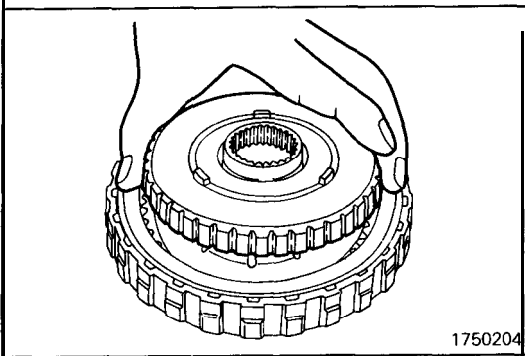

(67) Install the end clutch hub on the end clutch assembly.

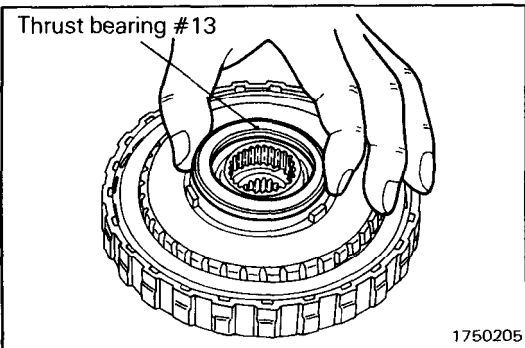

(68) Attach thrust bearing #13 to the end clutch hub with petrolatum jelly.

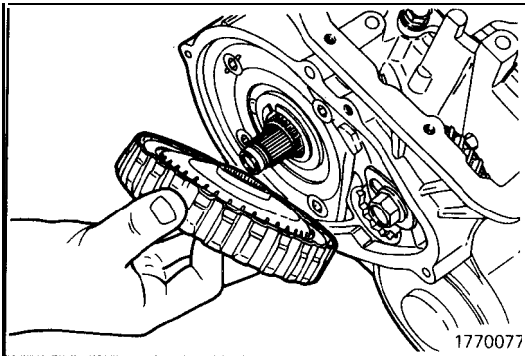

(69) Install the end clutch assembly.

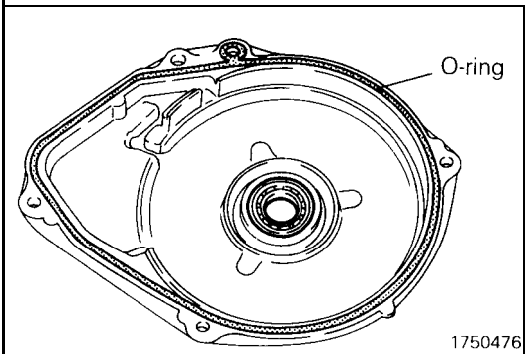

(70) Install new O-ring in the groove of the end clutch cover. Check the bearing for smooth rotation and replace it if defects are evident. Apply an ample amount of automatic transmission fluid to the bearing.

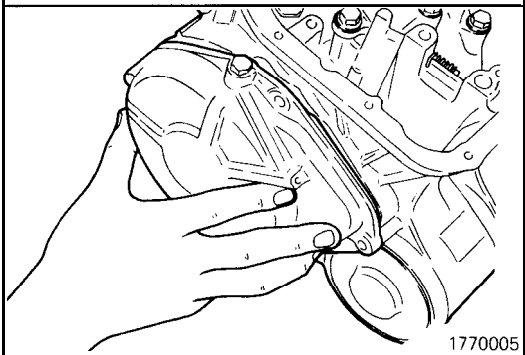

(71) Secure the end clutch cover by tightening its mounting bolts to specified torque.

Tightening torque: 7 Nm (5 ft.lbs.)

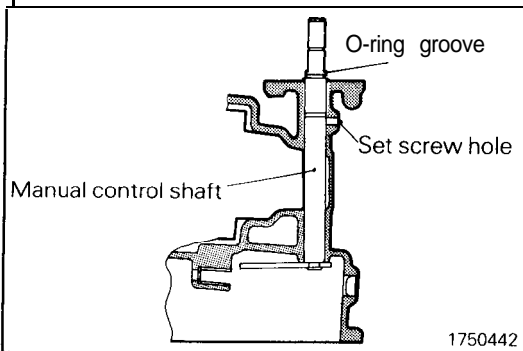

(72) Install the parking sprag rod to the manual control shaft. Then, insert the shaft in the transaxle as shown in the illustration. In doing this work, do not install O-ring in the O-ring groove.

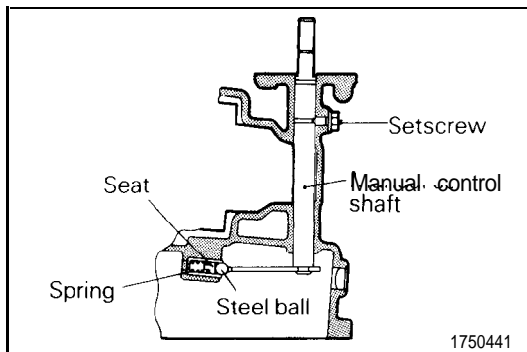

(73) After installing a new O-ring on the manual control shaft assembly, draw the shaft back into the case, then install the set screw and gasket. Also install the detent steel ball, seat and spring at the same time.

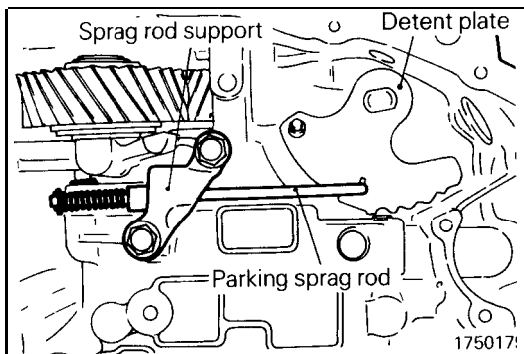

(74) Place the case with the oil pan mounting surface up.
 (75) Install the sprag rod support and tighten the two bolts to specified torque.

Tightening torque: 24 Nm (18 ft.lbs.)

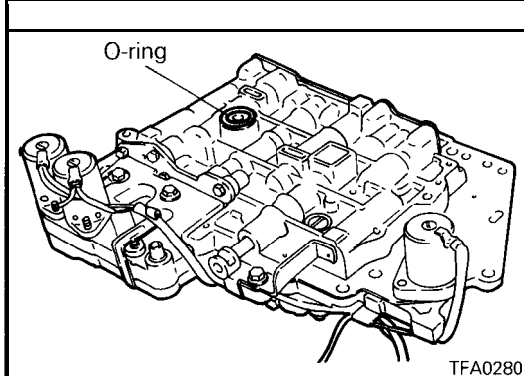

(76) Install the O-ring at the top of the valve body.
 (77) Replace the O-ring of the solenoid valve connector with a new one.

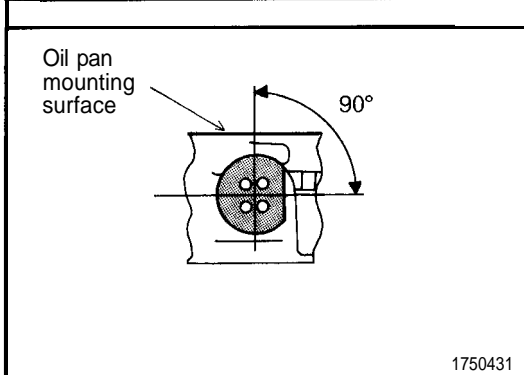

(78) When installing the valve body, insert the solenoid valve connector in the case, while making sure that cut of connector is positioned as shown in the illustration. (F4A21, F4A22)

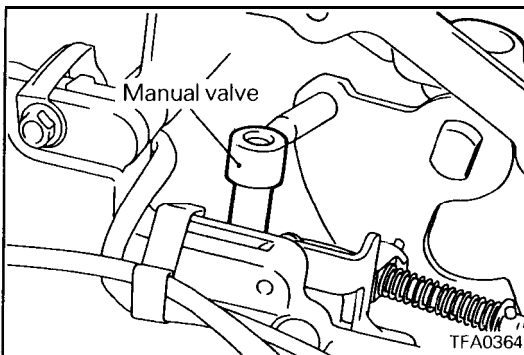

(79) Install the valve body in the transaxle case while fitting the detent plate pin in the gap between the lands of the manual valve.

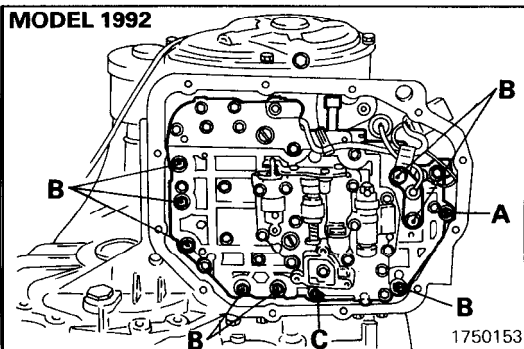

(80) Tighten the valve body mounting bolts (10 pieces) to the specified torque.

- A bolt 18 mm (.709 in.) long
- B bolt 25 mm (.984 in.) long
- C bolt 40 mm (1.575 in.) long

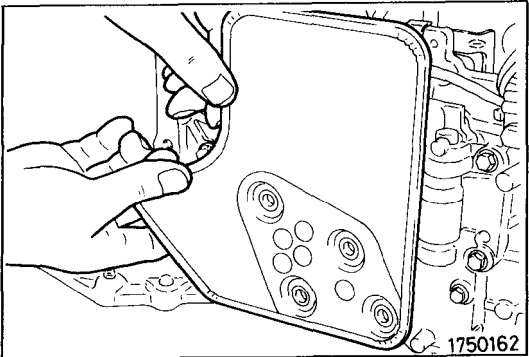
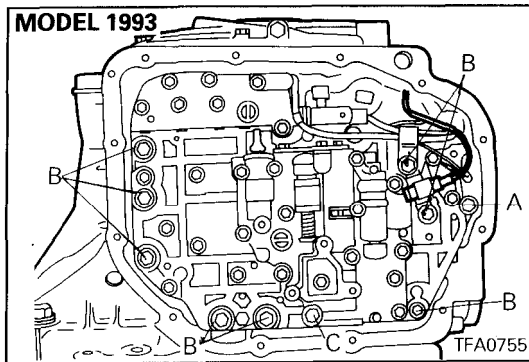

(81) Install the oil filter and tighten the four oil filter mounting bolts to the specified torque.

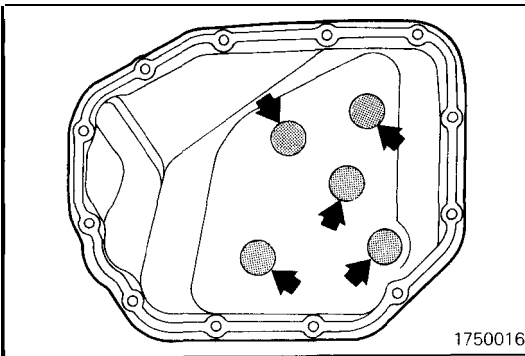

(82) Install five magnets in the five depressions provided inside the oil pan.

Be sure to remove metal particles from the magnets and clean the inside of the oil pan beforehand.

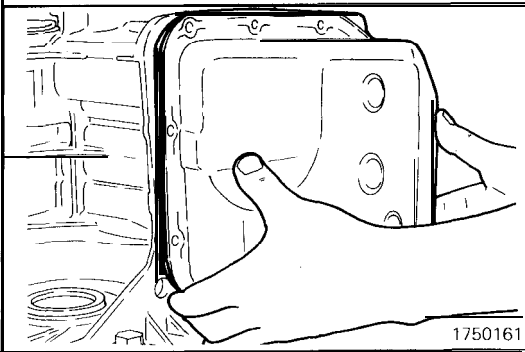

(83) Clean the gasket surfaces of the transaxle case and oil pan. Install a new oil pan gasket and then the oil pan by tightening the 12 bolts to the specified torque.

Tightening torque: 11 Nm (8 ft.lbs.)

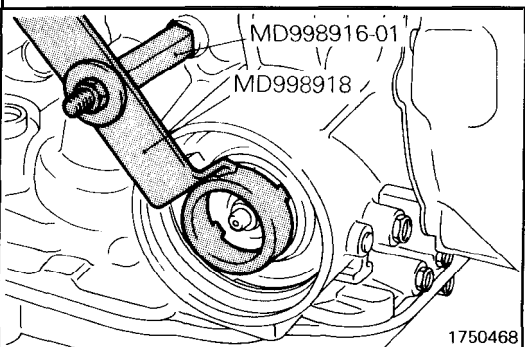

(84) Adjust the kickdown servo by the following procedure:

- (a) Fit the claw of the special tool in the notch of the piston to prevent the piston from turning, and use adapter to secure it as illustrated at left.

Caution

1. Do not push in the piston with the special tool.
2. When the adapter is installed to the transaxle case, do not apply excessive torque but tighten with a hand.

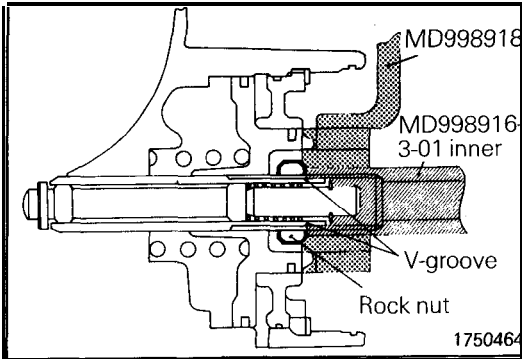

- (b) Loosen the lock nut until it is about to reach the V groove in the adjusting rod. Tighten the special tool (inner) until it touches the lock nut.

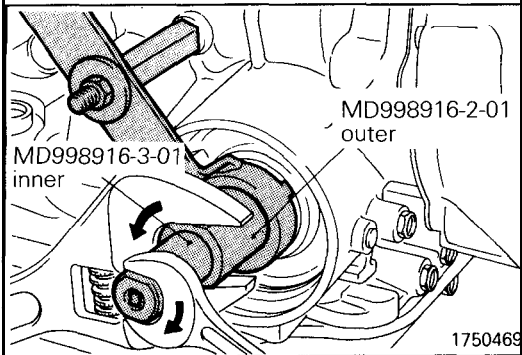

- (c) Fit the special tool (outer) to the lock nut. Turn the outer cylinder counterclockwise and the inner cylinder clockwise to lock the lock nut and the special tool (inner).

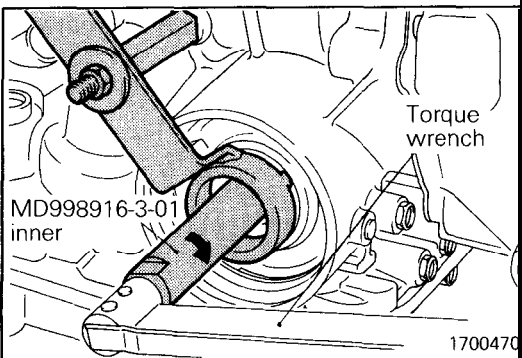

- (d) Fit torque wrench to the special tool (inner) to tighten it to a torque of 10 Nm (7.2 ft.lbs.) and loosen. Repeat this sequence two times before tightening the special tool (inner) to 5 Nm (3.6 ft.lbs.) torque. Then back off the special tool (inner) 2 to 2¼ turns (F4A21 and F4A22), or 2½ to 2¾ turns (F4A23).

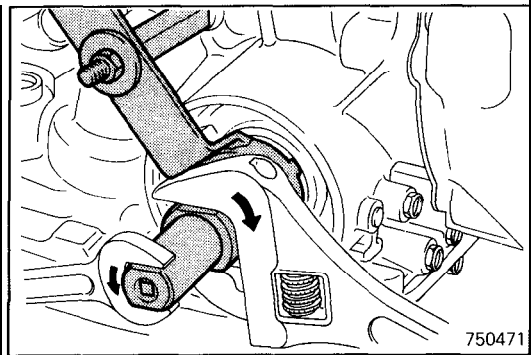

- (e) Fit the special tool (outer) to the lock nut. Turn the outer cylinder clockwise and the inner cylinder counterclockwise to unlock the lock nut and the special tool (inner).

Caution

When unlocking is carried out, apply equal force to both special tools to loosen.

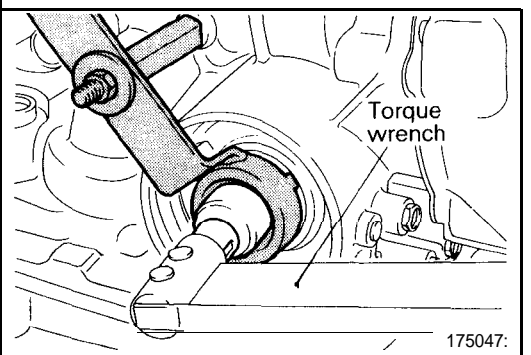

- (f) Tighten the lock nut with a hand until it touches the piston. Then, use torque wrench to tighten the lock nut to specified torque.

Lock nut: 29 Nm (21 ft.lbs.)

Caution

The lock nut may turn with the adjusting rod if tightened quickly with socket wrench or torque wrench.

- (g) Remove the special tool for securing the piston. Install the plug to the Low/Reverse pressure outlet and tighten to specified torque.

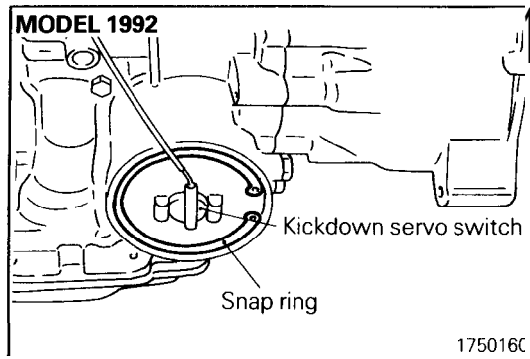

(85) Set a new D-ring in the kickdown servo switch, push the switch into the case and secure it with the snap ring.

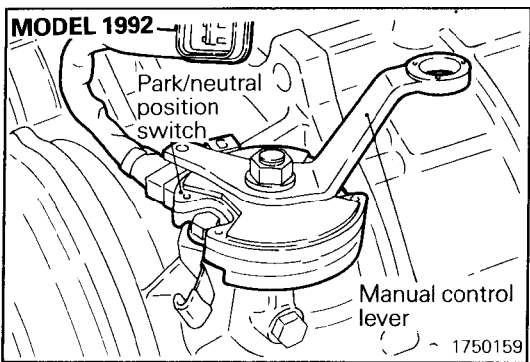
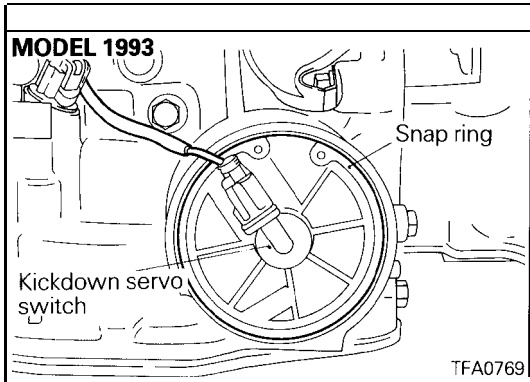

(86) Install the park/neutral position switch and manual control lever, and tighten the manual control lever nut to the specified torque.

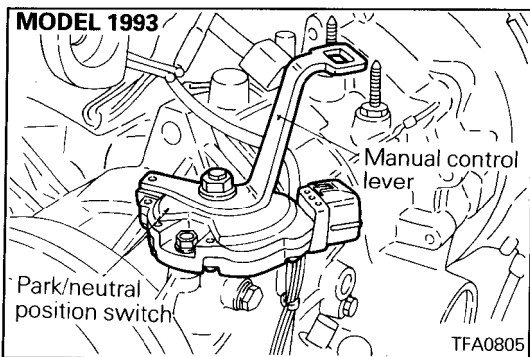

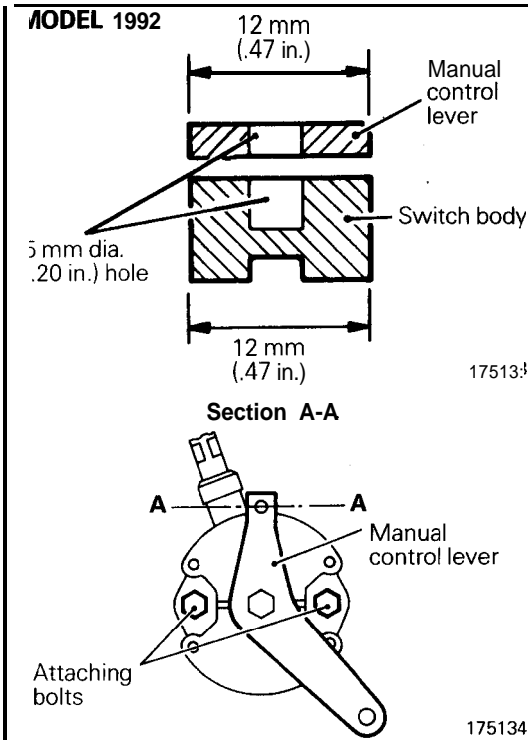

(87) Adjust the park/neutral position switch as follows:

- (a) Place the manual control lever in the "N" (neutral) position.
- (b) Turn the park/neutral position switch body until the 12 mm (.47 in.) wide end of the manual control lever aligns with the switch body flange [12 mm (.47 in.) wide portion]. Alternatively, turn the switch body until the 5 mm (.20 in.) hole in the manual control lever aligns with the 5 mm (.20 in.) hole in the switch body.
- (c) Tighten the attaching bolts to the specified torque taking care that switch body is not displaced.

Tightening torque: 11 Nm (8 ft.lbs.)

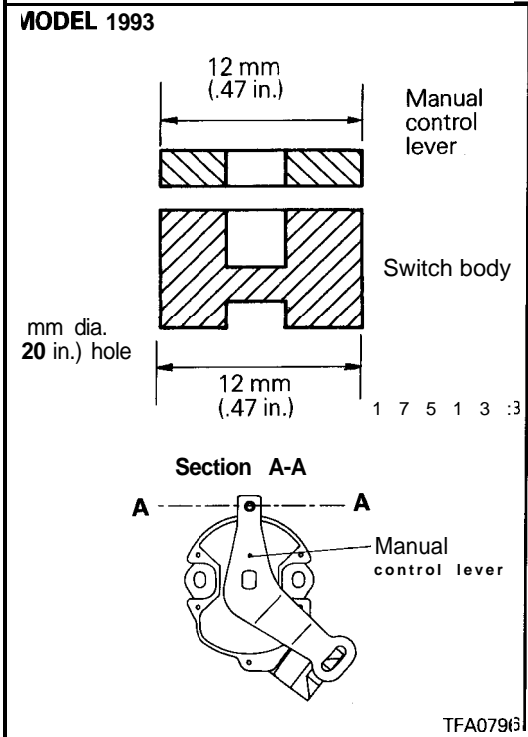

MODEL 1992

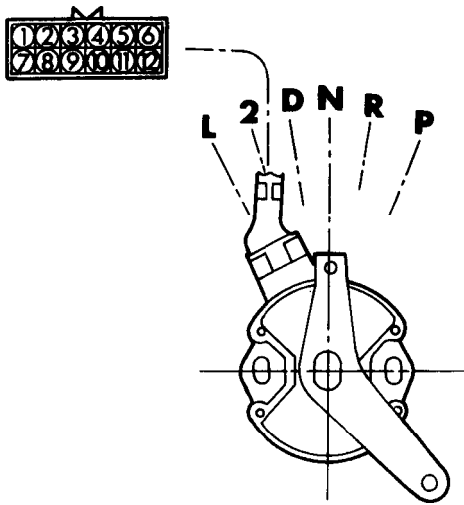

1750149

MODEL 1993

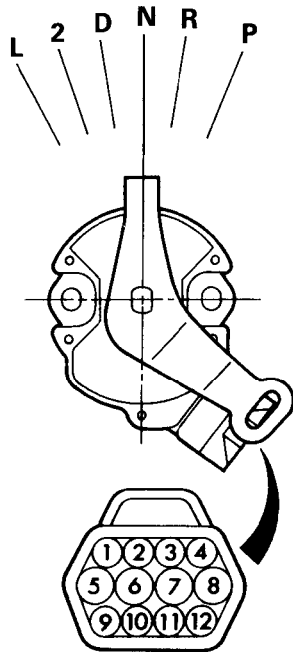

TFA0793

(88) Check the continuity between terminals with the manual control lever at each position. The continuity between terminals should be as shown in the table below.

Internal Connection in the Inhibitor Switch – MODEL 1992

Terminal No.	P	R	N	D	2	L	Connected circuits
1					○		Transaxle control unit
2			○				Transaxle control unit
3	○						Transaxle control unit
4	○	○	○	○	○	○	Ignition switch "ON" terminal
5		○				○	Transaxle control unit
6				○			Transaxle control unit
7		○					Transaxle control unit
8	○		○				Ignition switch "ST" terminal
9	○		○				Starter motor "S" terminal
10		○					Ignition switch "ON" terminal
11							Backup lamp

Internal Connection in the Inhibitor Switch – MODEL 1993

Terminal No.	P	R	N	D	2	L	Connected circuits
1	○						Transaxle control module
2			○				Transaxle control module
3					○		Transaxle control module
4	○	○	○	○	○	○	Ignition switch "ON" terminal
5	○		○				Ignition switch "ST" terminal
6		○					Backup lamp
7		○					Ignition switch "ON" terminal
8	○		○				Starter motor "S" terminal
9				○			Transaxle control module
10		○					Transaxle control module
11						○	Transaxle control module

Lack of continuity indicates a poorly adjusted switch or faulty switch. Readjust the switch. If still without continuity, replace the switch.

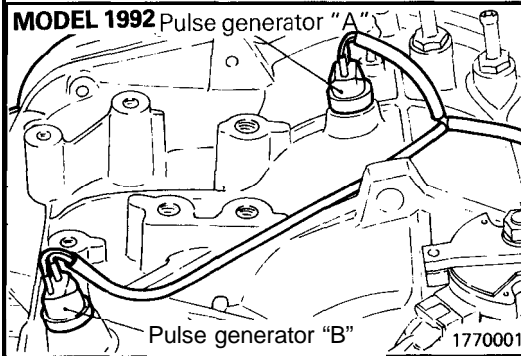

(89) Install pulse generators "A" and "B" and tighten the bolt to the specified torque.

Tightening torque: 11 Nm (8 ft.lbs.)

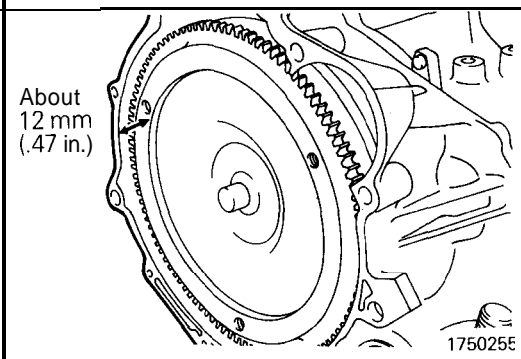
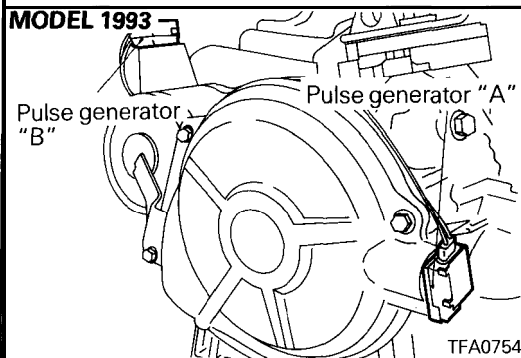

(90) After applying automatic transmission fluid to the outside surface of the oil pump-side cylindrical portion of the torque converter, install the torque converter carefully so as not to give damage to the oil seal lip. Make certain that the torque converter is in mesh with the oil pump drive gear.

(91) Measure the distance between the ring gear end and the converter housing end.

The torque converter has been properly installed when the measurement is about 12 mm (.47 in.).

OIL PUMP

DISASSEMBLY AND REASSEMBLY

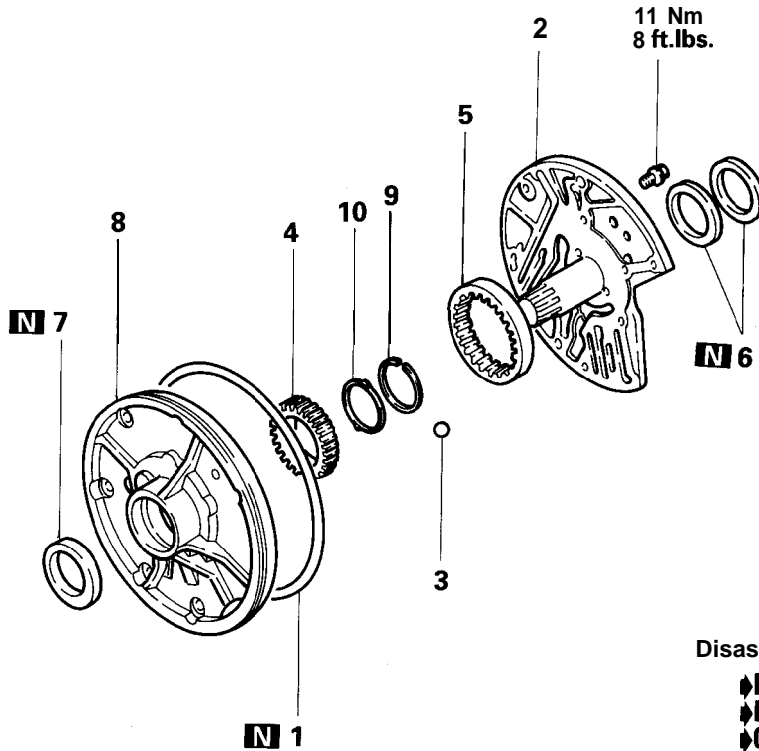

Disassembly steps

- ◆E◆ 1. O-ring
- ◆D◆ 2. Reaction shaft support
- ◆C◆ 3. Steel ball
- ◁A▷ ◆B◆ 4. Drivegear
- ◁A▷ ◆B◆ 5. Driven gear
- 6. Seal ring
- ◆A◆ 7. Oil seal
- 8. Oil pump housing
- 9. Snap ring
- 10. Oil seal

1750261

DISASSEMBLY SERVICE POINT

◁A▷ **DRIVE GEAR / DRIVEN GEAR REMOVAL**

(1) Make reassembly alignment marks on the drive and driven gears.

REASSEMBLY SERVICE POINTS

◆A◆ **OIL SEAL INSTALLATION**

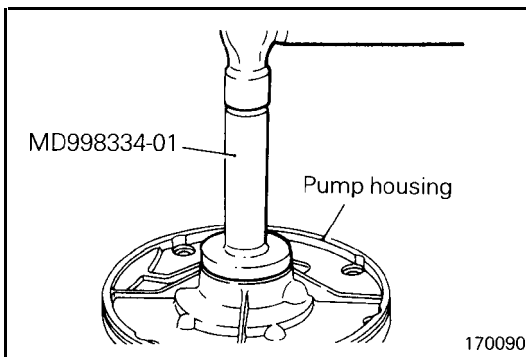

170090

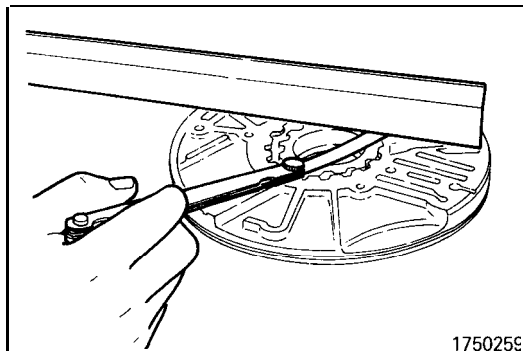

◆B◆ DRIVEN GEAR / DRIVE GEAR SIDE CLEARANCE MEASUREMENT

Standard value:
0.03 – 0.05 mm (.001 – .002 in.)

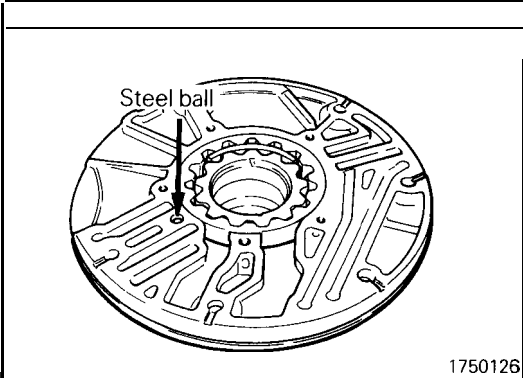

◆C◆ STEEL BALL LOCATION

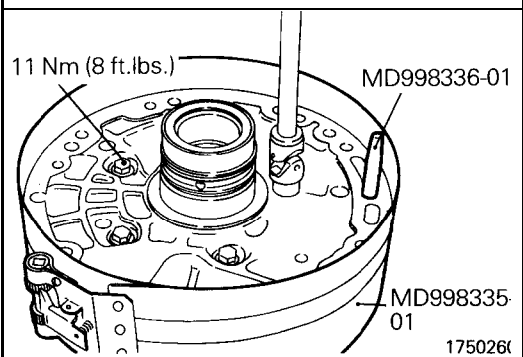

◆D◆ REACTION SHAFT SUPPORT INSTALLATION

- (1) Assemble the reaction shaft support and the pump housing, and tighten the five bolts by fingers.
- (2) Insert the special tool (Guide Pin MD998336-01) in the oil pump bolt hole and tighten the peripheries of the support and housing with the special tool (Band MD998335-01) to locate the support and housing.
- (3) Tighten the five bolts to the specified torque.
- (4) Make sure that the oil pump gear turns freely.

◆E◆ O-RING INSTALLATION

- (1) Install a new O-ring in the groove of the pump housing and apply petrolatum jelly to the O-ring.

FRONT CLUTCH

DISASSEMBLY AND REASSEMBLY

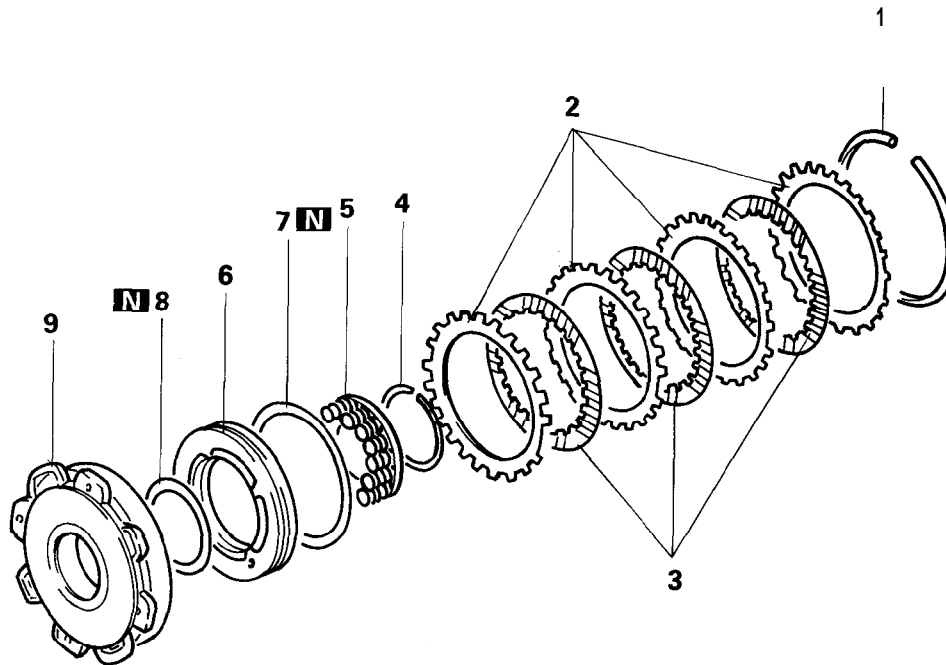

TFA0029

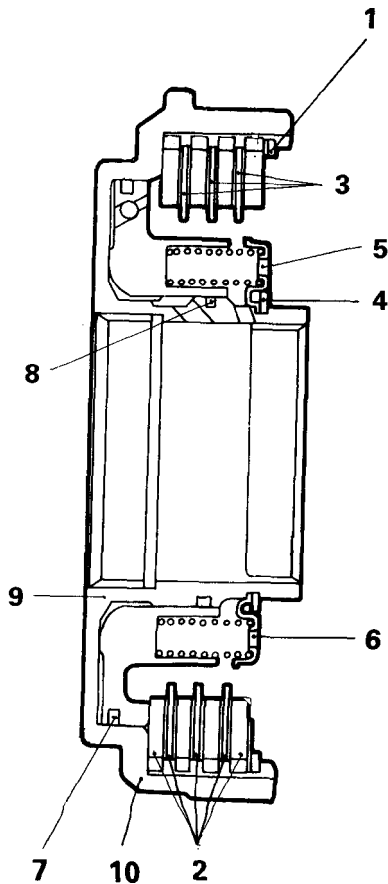

Disassembly steps

- ▶C▶ 1. Snap ring
- ▶B▶ 2. Clutch reaction plate
- 3. Clutch disc
- ◀A▶▶A▶ 4. Snap ring
- 5. Return spring
- 6. Front clutch piston
- 7. D-ring
- 8. D-ring
- 9. Front clutch retainer

No. of Clutch Discs and Clutch Reaction Plate

Model	Clutch disc	Clutch reaction plate
F4A21	2	3
F4A22, F4A23	3	4

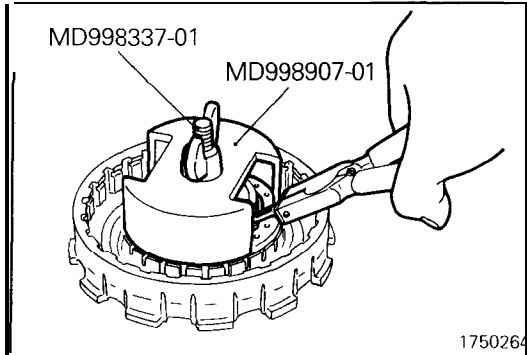

DISASSEMBLY SERVICE POINT

◀A▶ SNAP RING REMOVAL

- (1) Compress the return spring with the special tool.
- (2) Remove the snap ring.

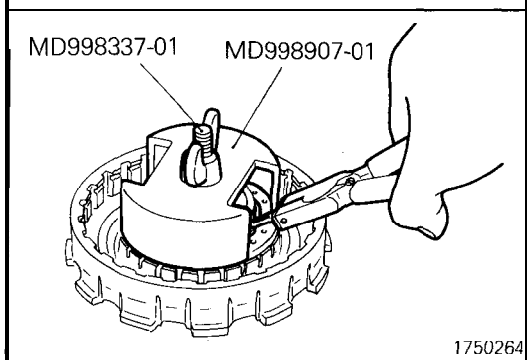

REASSEMBLY SERVICE POINTS

▶A◀ SNAP RING INSTALLATION

- (1) Compress the return spring with the special tool.
- (2) Install the snap ring.

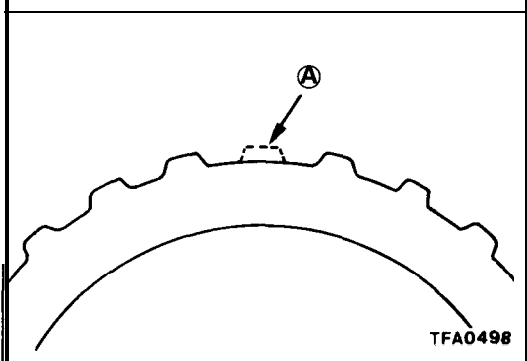

▶B◀ CLUTCH REACTION PLATE INSTALLATION

- (1) Install the clutch reaction plate with their missing tooth portions (A in the illustration) in alignment.

NOTE

This design is to facilitate escape of automatic transmission fluid and improve the cooling efficiency of the plate and disc.

- (2) Install the innermost the reaction plate with their shear droops directed as shown in the illustration.

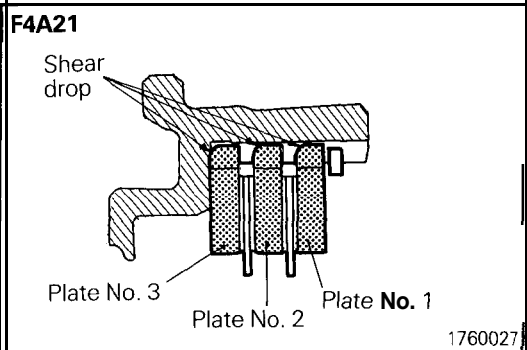

Identification of reaction plate

mm (in.)

Plate No.	F4A21		F4A22 (except F4A22-2-MQD6)		F4A22-2-MQD6, F4A23	
	Thick-ness	Identifi-cation mark	Thick-ness	Identifi-cation mark	Thick-ness	Identifi-cation mark
1	3.8 (.150)	R	3.8 (.150)	R	5.0 (.197)	A
2	3.7 (.146)	None	3.7 (.146)	None	3.1 (.122)	B
3	3.7 (.146)	None	3.7 (.146)	None	3.1 (.122)	B
4			3.7 (.146)	None	3.7 (.146)	None

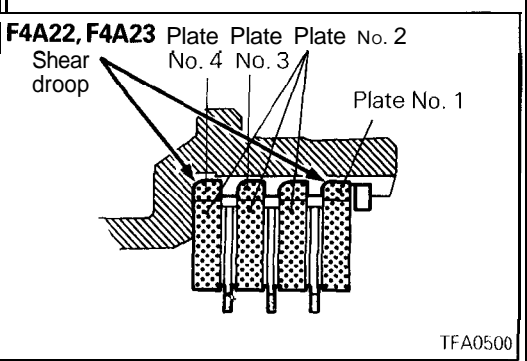

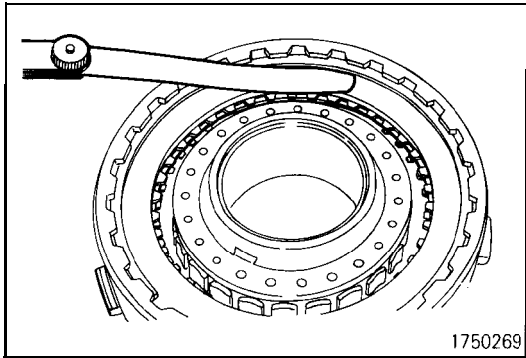
**◆C◆ SNAP RING SELECTION**

- (1) Check clearance between the snap ring and clutch reaction plate. To check the clearance, hold entire circumference of the clutch reaction plate down with 50 N (11 lbs.) force. If clearance is out of standard value, select a snap ring to obtain the standard value.

Standard value:**F4A22, F4A23**

0.7 – 0.9 mm (.028 – .035 in.)

F4A21

0.4 – 0.6 mm (.016 – .024 in.)

NOTE

To install the return spring snap rings, set the rings with their end gaps 180° apart.

REAR CLUTCH

DISASSEMBLY AND REASSEMBLY

No. of Clutch Discs and Plates

Model	Clutch disc	Clutch plate
F4A21	2	1
F4A22, F4A23	3	2

Disassembly steps

- 1. Seal ring
- ▶D▶ 2. Input shaft
- 3. O-ring
- 4. Snap ring
- 5. Thrust race
- 6. Seal ring
- ▶C▶ 7. Snap ring
- ▶B▶ 8. Clutch reaction plate
- ▶B▶ 9. Clutch disc
- ▶B▶ 10. Clutch plate
- ▶B▶ 11. Clutch pressure plate
- ◀A▶ ▶A▶ 12. Wave spring
- 13. Return spring
- 14. Rear clutch piston
- 15. Rear clutch retainer
- 16. D-ring
- 17. D-ring

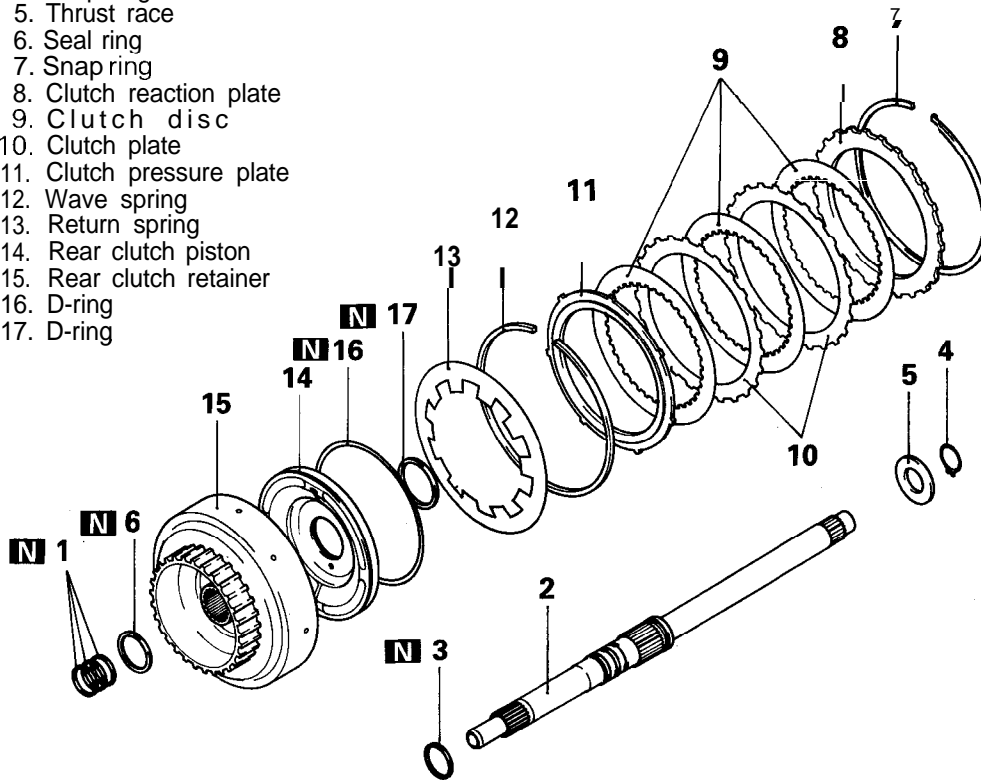

TFAO 621

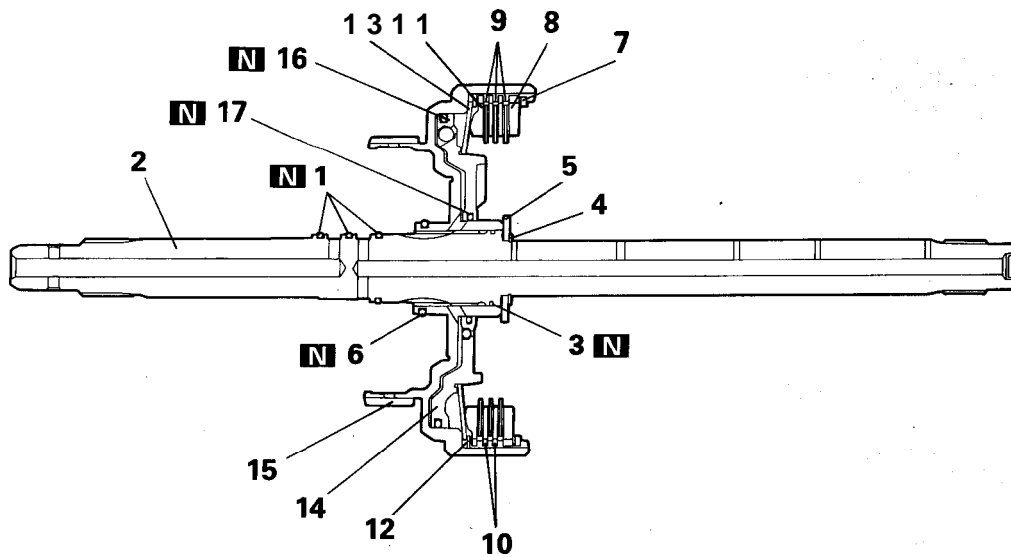

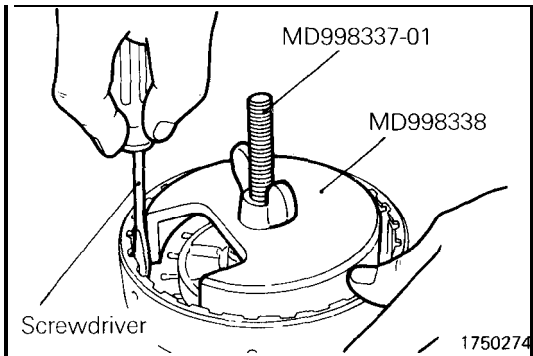

DISASSEMBLY SERVICE POINT

◆A◆ WAVE SPRING REMOVAL

- (1) Compress the return spring with the special tool.
- (2) Using a screwdriver, remove the wave spring.

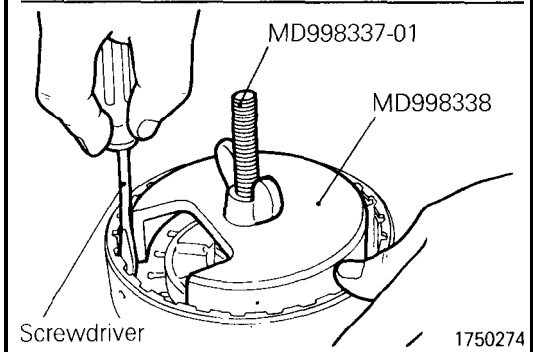

REASSEMBLY SERVICE POINTS

◆A◆ WAVE SPRING INSTALLATION

- (1) Compress clutch reaction plate with the special tool.
- (2) Install the wave spring.

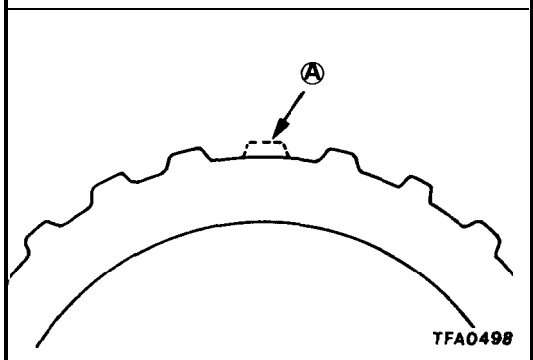

◆B◆ CLUTCH PRESSURE PLATE / CLUTCH PLATE / CLUTCH REACTION PLATE INSTALLATION

- (1) Install the clutch pressure plate, clutch plates and clutch reaction plate with their missing tooth portions (A) in alignment.

NOTE

This design is to facilitate escape of automatic transmission fluid and improve the cooling efficiency of the plates and disc.

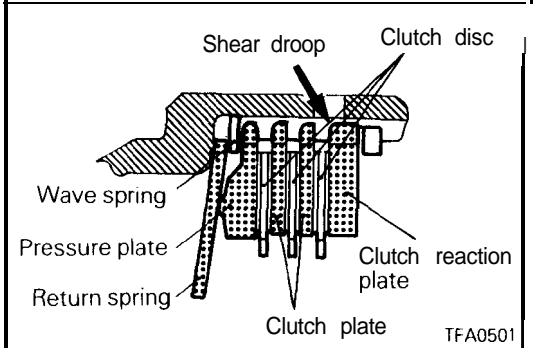

- (2) Install the clutch reaction plate with its shear droop directed as shown in the illustration.

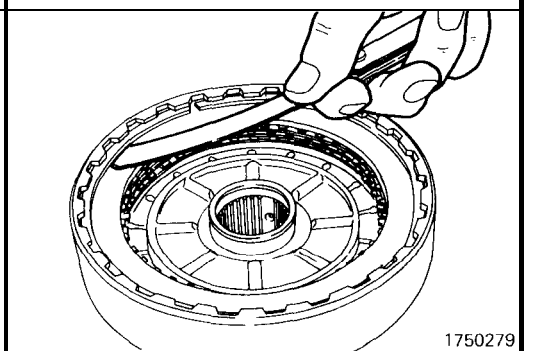

◆C◆ SNAP RING SELECTION

- (1) Check clearance between the snap ring and clutch reaction plate. To check the clearance, hold entire circumference of the clutch reaction plate down with 50 N (5 kg, 11 lbs.) force. If clearance is out of standard value, select a snap ring to obtain the standard value.

Standard value:

F4A22, F4A23
F4A21

0.4 – 0.6 mm (.016 – .024 in.)
0.3 – 0.5 mm (.012 – .020 in.)

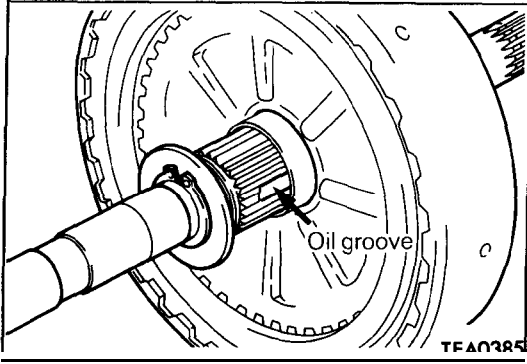

◆D◆ INPUT SHAFT INSTALLATION

- (1) Install the input shaft with its oil groove aligned with the oil hole in the rear clutch retainer.

END CLUTCH

DISASSEMBLY AND REASSEMBLY

No. of Clutch Discs and Plates

Model	Clutch disc	Clutch plate
F4A2 1, F4A22	3	3
F4A23	4	4

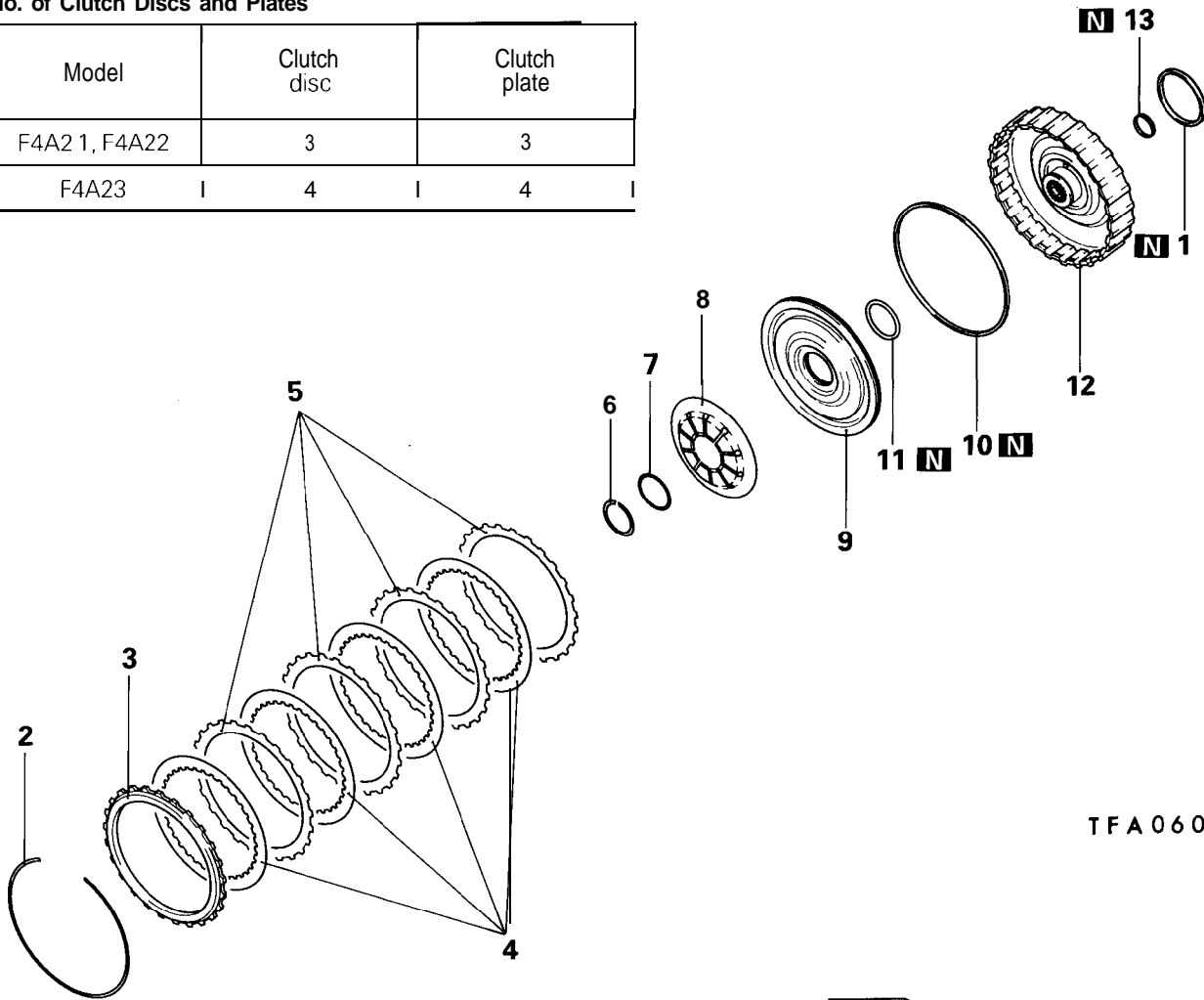

TFA0607

Disassembly steps

- 1. Seal ring
- ▶B▶ 2. Snap ring
- 3. Clutch reaction plate
- 4. Clutch disc
- 5. Clutch plate
- ▶A▶ 6. Snap ring
- 7. Washer
- 8. Return spring
- ◁A▶ 9. End clutch piston
- 10. Oil seal
- 11. D-ring
- 12. End clutch retainer
- 13. Oil seal

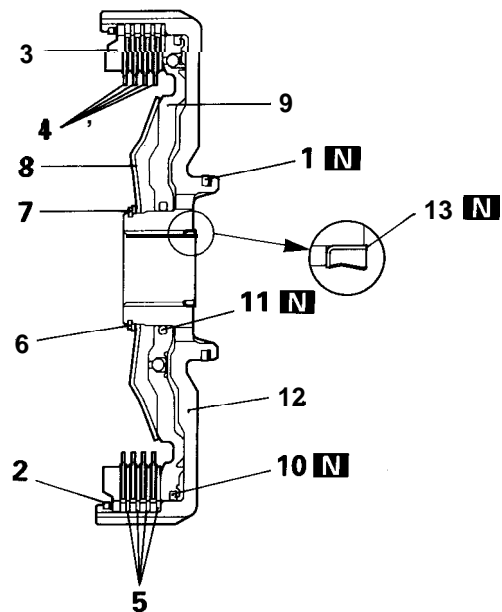

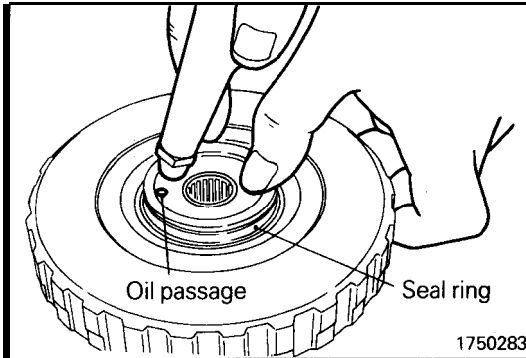

DISASSEMBLY SERVICE POINT

◀A▶ END CLUTCH PISTON REMOVAL

- (1) Remove the piston. If it is hard to remove, place the retainer on the workbench with piston side down and blow air through the oil passage in the back of retainer.

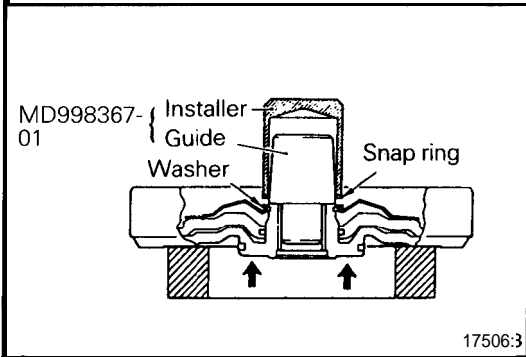

REASSEMBLY SERVICE POINTS

▶A▶ SNAP RING INSTALLATION

- (1) Fit a new snap ring to the Guide of the special tool, and install it to the retainer. Be sure to fit snap ring to the lowest possible portion of the Guide. Put the Installer over the Guide and use a press to install the snap ring in the groove. If the snap ring is installed in the groove, stop using the press. Do not use the press more than necessary, Further, be sure not to support the portion (center protruded portion) marked with arrows in the illustration.

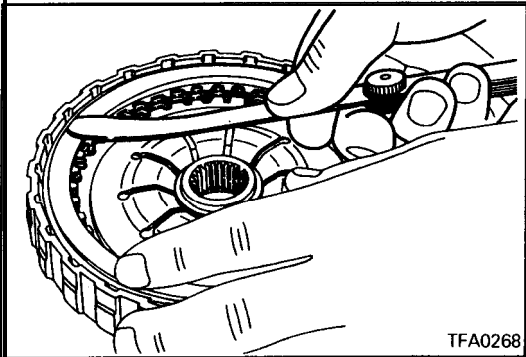

▶B▶ SNAP RING SELECTION

- (1) Check clearance between the snap ring and clutch reaction plate. To check the clearance, hold entire circumference of the clutch reaction plate down with 50 N (11 lbs.) force. If clearance is out of standard value, select a snap ring to obtain the standard value.

Standard value:

F4A21, F4A22
F4A23

0.4 – 0.65 mm (.016 – .026 in.)
0.6 – 0.85 mm (.024 – .031 in.)

PLANETARY GEAR

DISASSEMBLY AND REASSEMBLY

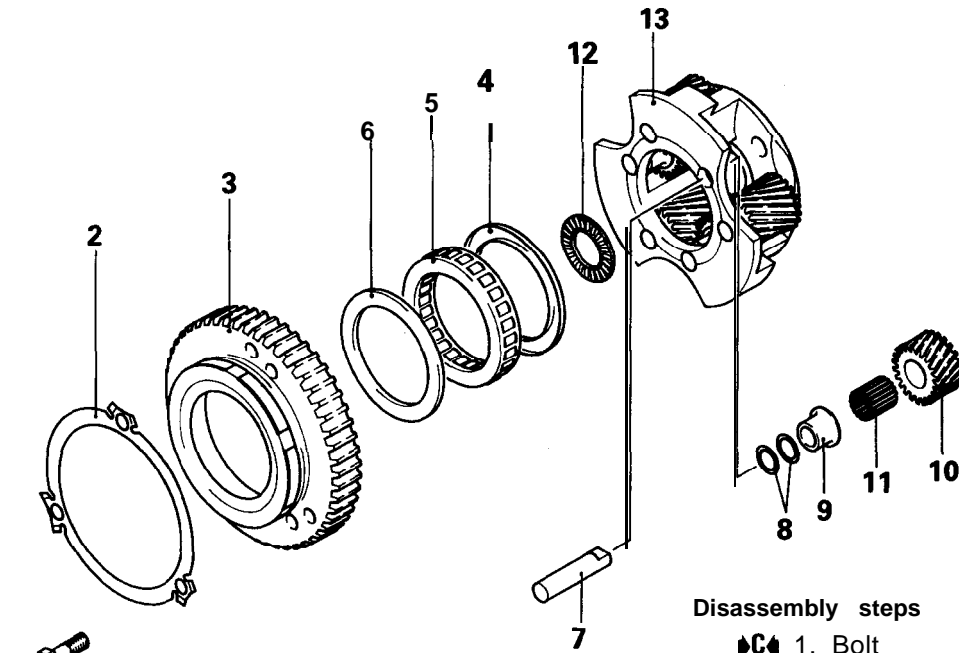

TFA0522

Disassembly steps

- ↔C↔ 1. Bolt
- 2. Lock plate (except F4A22-2-MQD6, F4A23-2-LNN, LNQ)
- 3. One-way clutch outer race
- 4. End plate
- ↔B↔ 5. One-way clutch
- 6. End plate
- 7. Pinion shaft
- 8. Front thrust washer
- 9. Spacer bushing
- 10. Short pinion
- 11. Roller
- ↔A↔↔A↔ 12. Thrust bearing
- 13. Planet carrier

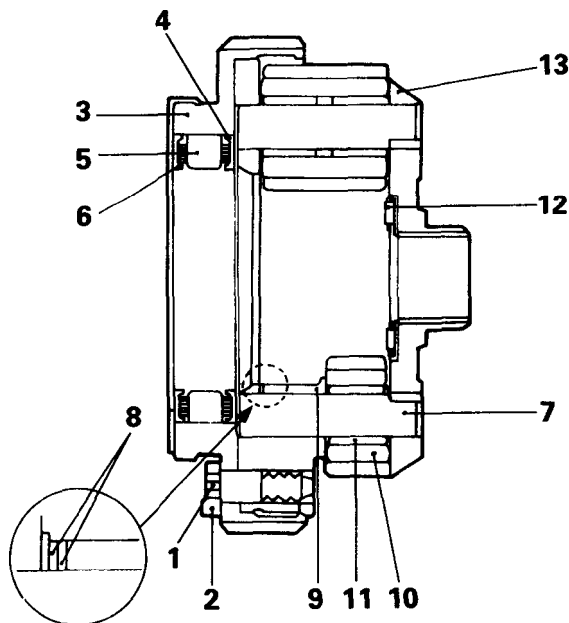

TFA0524

TFA0524

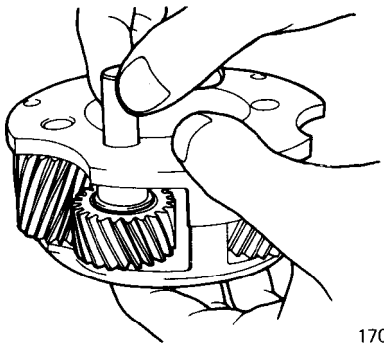

170255

DISASSEMBLY SERVICE POINT**◀A▶ THRUST BEARING REMOVAL**

- (1) Remove the only one short pinion. Use care not to drop and lose the 17 rollers in the short pinion. Do not remove the other short pinions.

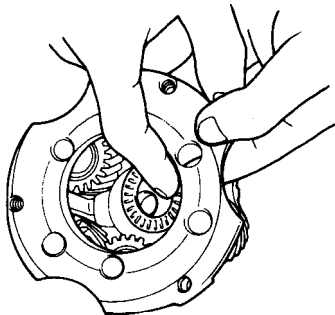

170256

- (2) Remove the thrust bearing.

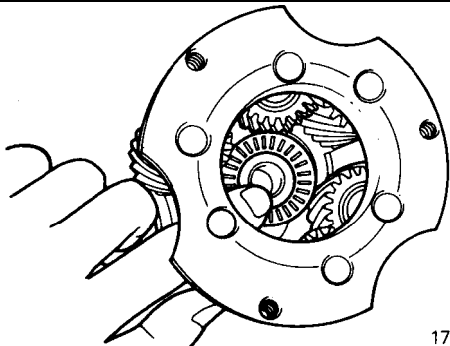

17025E

REASSEMBLY SERVICE POINTS**▶A▶ THRUST BEARING INSTALLATION**

- (1) Install a new thrust bearing on the carrier. Make sure that it fits correctly in the spot faced portion of the carrier.

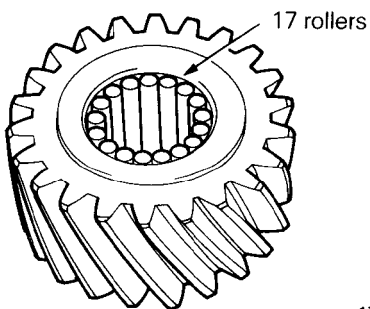

1750291

- (2) Apply Vaseline unsparingly to the inside surface of the short pinion and attach the 17 rollers on the surface.

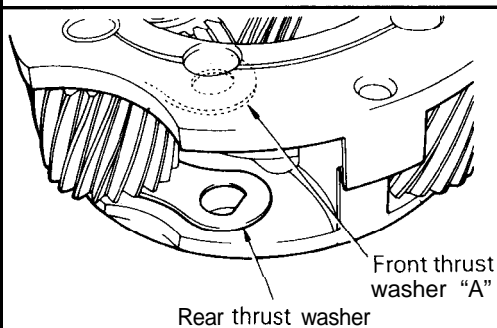

17026C

- (3) Line up the holes of the rear thrust washer and front thrust washer "A" with the shaft hole of the carrier.
- (4) Install the short pinion, spacer bushing and front thrust washer and align the holes. Use care not to allow the rollers to get out of position.

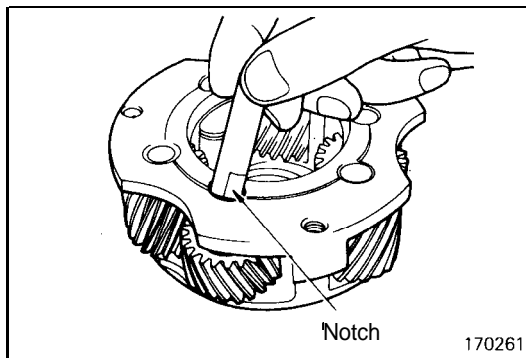

- (5) Insert the pinion shaft. Make sure that the flattened end of pinion shaft is correctly fitted in the hole of the rear thrust plate when the pinion shafts is inserted.

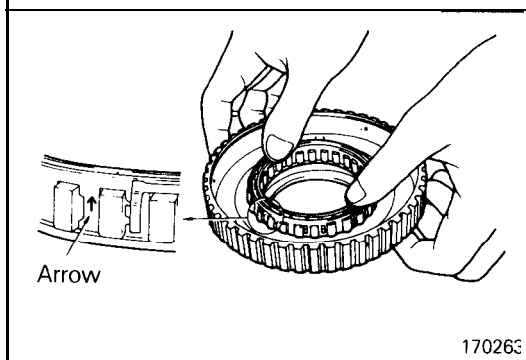

◆B◆ ONE-WAY CLUTCH INSTALLATION

- (1) Push the one-way clutch into the outer race. Make sure that arrow on the outside circumference of cage is directed upward as shown in the illustration when the one-way clutch is pushed in.

◆C◆ BOLT INSTALLATION

NOTE

Do not reuse the pre-coated bolt (F4A22 and F4A23).

ANNULUS GEAR AND TRANSFER DRIVE GEAR SET DISASSEMBLY AND REASSEMBLY

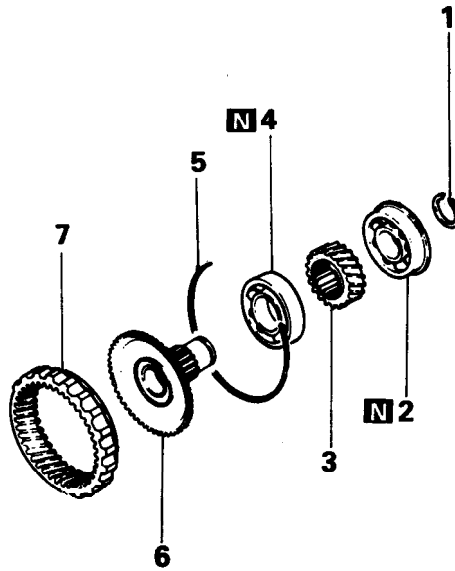

Disassembly steps

- 1. Snap ring
- 2. Bearing
- 3. Transfer drive gear
- 4. Bearing
- 5. Snap ring
- 6. Output flange
- 7. Annulus gear

170178

DISASSEMBLY SERVICE POINTS

◁A▷ BEARING REMOVAL

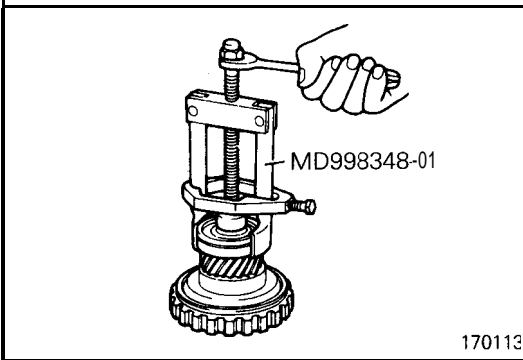

170113

◁B▷ TRANSFER DRIVE GEAR REMOVAL

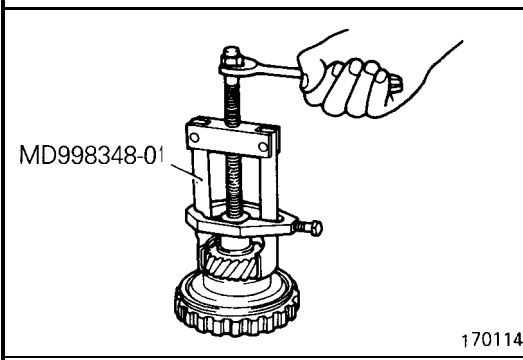

170114

◁C▷ BEARING REMOVAL

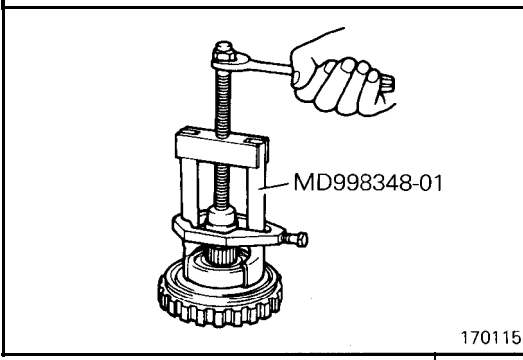

170115

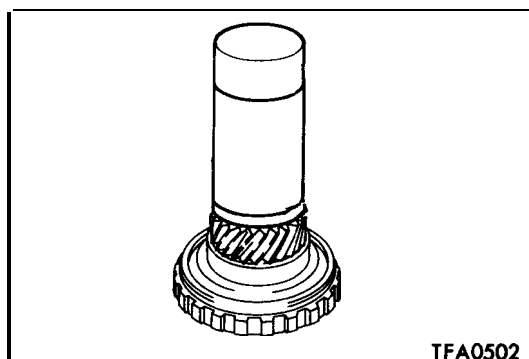

REASSEMBLY SERVICE POINTS

◆A◆ BEARING INSTALLATION

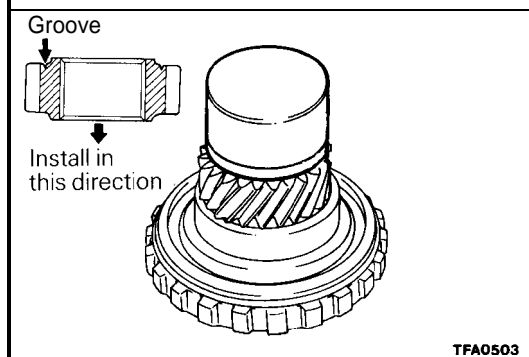

◆B◆ TRANSFER DRIVE GEAR INSTALLATION

- (1) Install the transfer drive gear in proper direction. The direction can be identified by the groove provided in one of the pinion side surfaces.

Caution

Replace the output flange and transfer drive gear as a set.

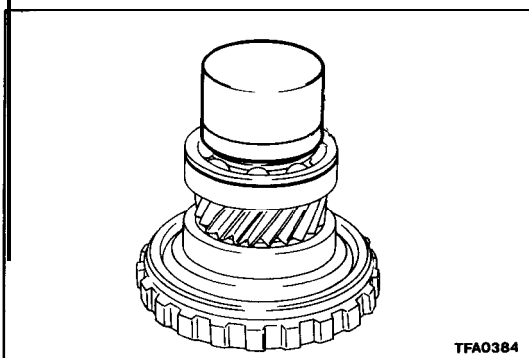

◆C◆ BEARING INSTALLATION

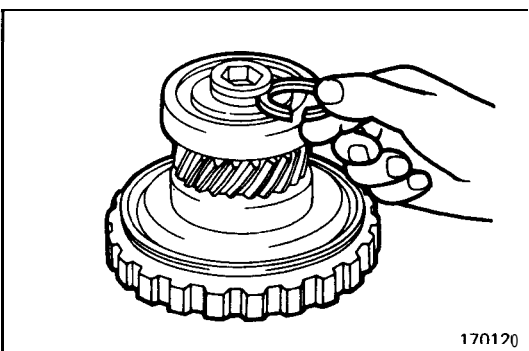

◆D◆ SNAP RING SELECTION

- (1) Select a snap ring, which should be the thickest one that can be installed in groove.

Standard value: 0 – 0.06 mm (0 – .0024 in.)

DIFFERENTIAL

DISASSEMBLY AND REASSEMBLY

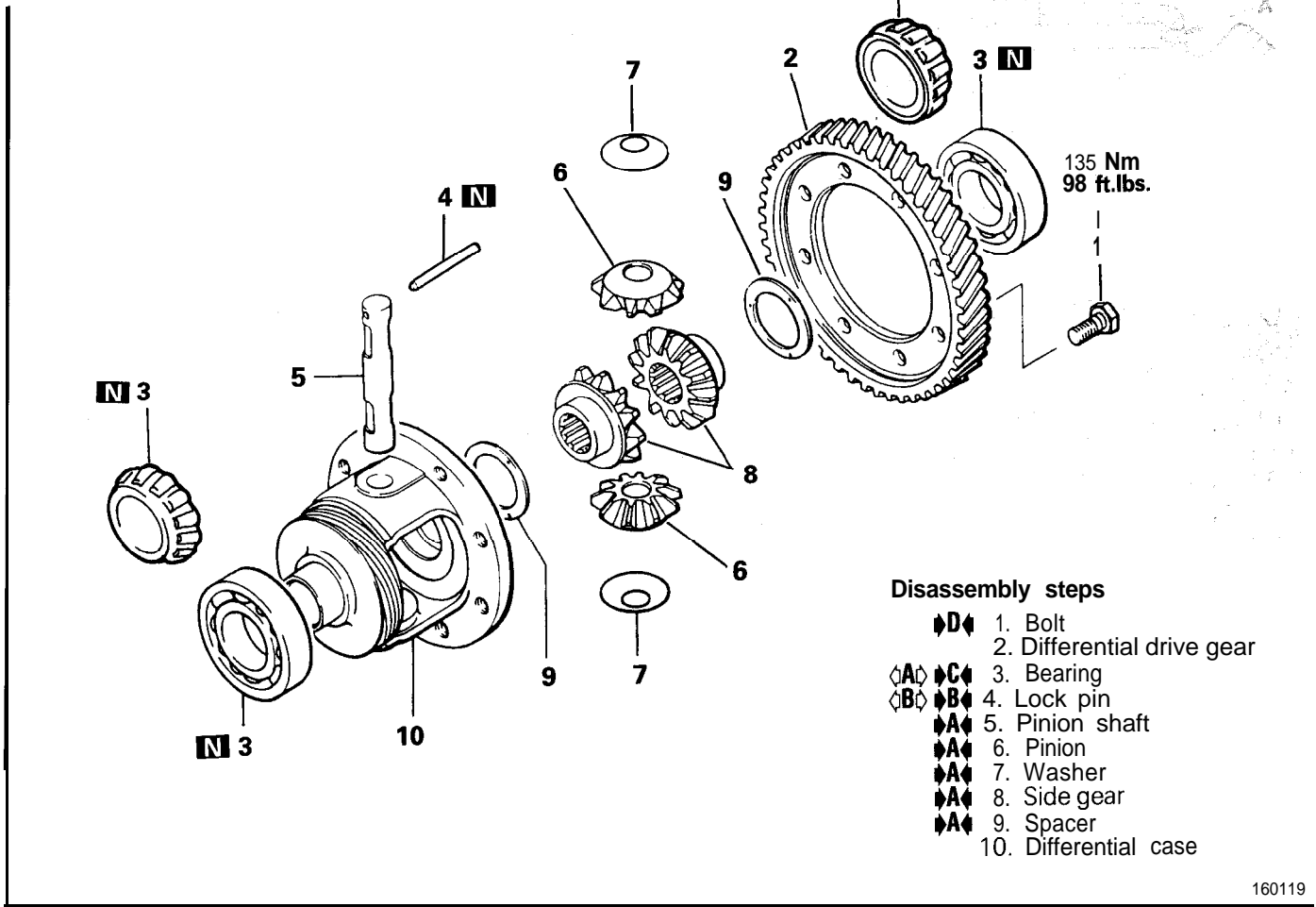

160119

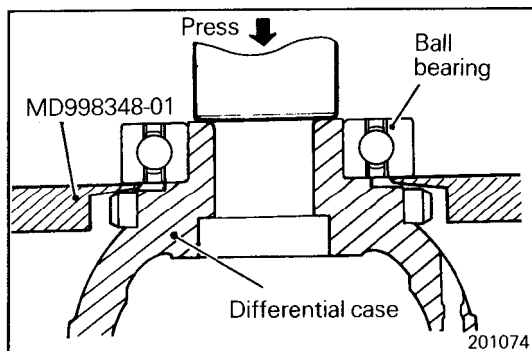

DISASSEMBLY SERVICE POINTS

◆A◆ BALL BEARING REMOVAL

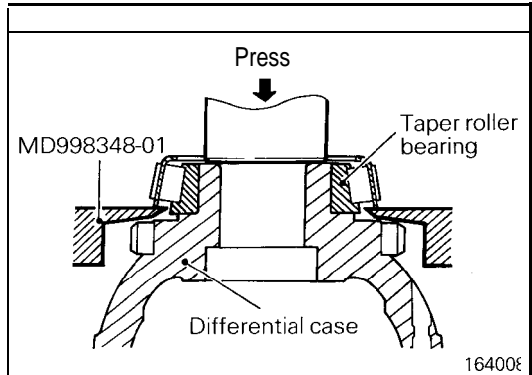

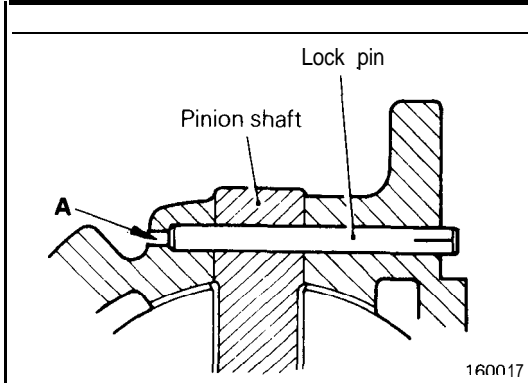

◊B◊ LOCK PIN REMOVAL

- (1) Drive out the lock pin with a punch inserted in hole "A".
- (2) Remove the pinion shaft from the case, and remove the pinion gears and washers.
- (3) Remove the side gears and spacers from the case.
Keep the removed gears and spacers for R.H. side use separated from those for L.H. side use.

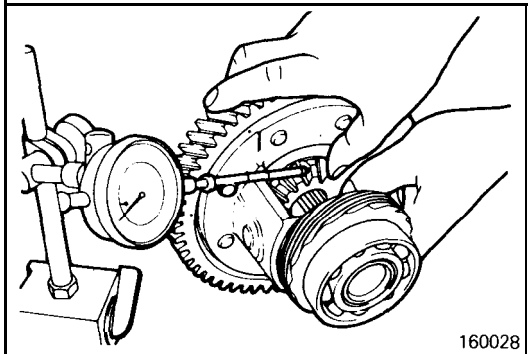

REASSEMBLY SERVICE POINTS

◆◆ SPACER / SIDE GEAR / WASHER / PINION / PINION SHAFT INSTALLATION

- (1) With the spacers installed on the back of the differential side gears, install the gears in the differential case. When reusing the removed parts, install them in the original positions noted during disassembly. When using new differential side gears, install spacers of medium thickness $1.0_{-0.07}^0$ mm ($.039_{-0.003}^0$ in.).
- (2) Install the washers to the back of the pinion gears, install the gears in the differential case, and then insert the pinion shaft.
- (3) Measure the backlash between the side gear and pinion gear. The backlash should be 0.025 to 0.150 mm (.0010 to .0059 in.) and the right and left gear pairs should have equal backlash. If the backlash is not within the specified range, disassemble, and reassemble them using spacers selected for correct backlash.

Backlash: 0.025 – 0.150 mm (.0010 – .0059 in.)

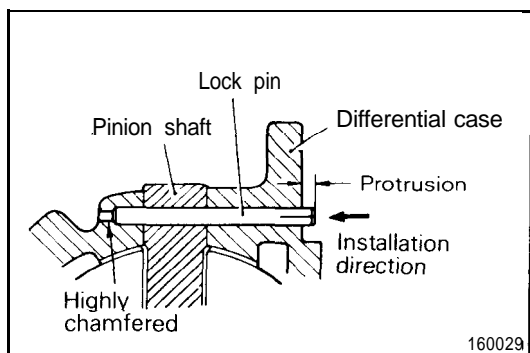

◆B◆ LOCK PIN INSTALLATION (F4A21)

- (1) Align the lock pin hole in the pinion shaft with that in the case and press fit the lock pin until its protrusion is 3 mm (0.12 in.) or less.

Caution

1. Do not reuse the lock pin.
2. Do not use a lock pin which requires only 2000 N (440 lbs.) or less force for installation.

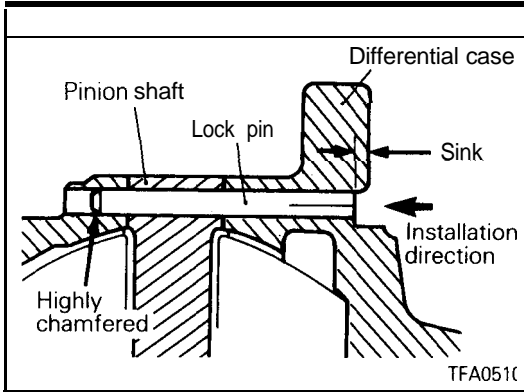

◆B◆ LOCK PIN INSTALLATION (F4A22)

- (1) Align the lock pin hole in the pinion shaft with that in the case and press fit the lock pin until its sink from the differential case end is 1 mm (.04 in.) or more.

Caution

1. Do not reuse the lock pin.
2. Do not use a lock pin which requires only 2000 N (440 lbs.) or less force for installation.

◆B◆ LOCK PIN INSTALLATION (F4A23)

- (1) Align the lock pin hole in pinion shaft with that in the case and install the lock pin.

Caution

The lock pin should be lower than the differential case flange surface.

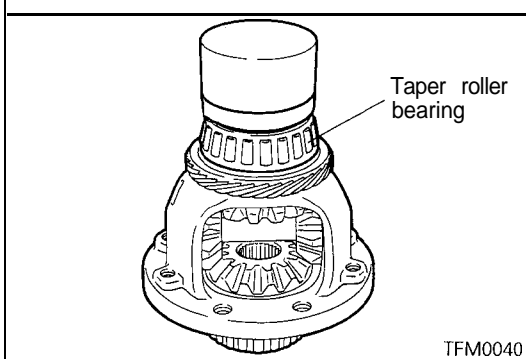
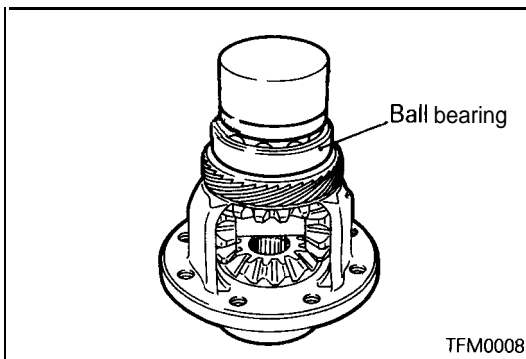

◆C◆ BEARING INSTALLATION

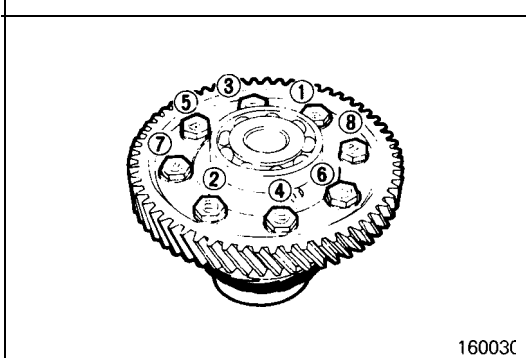

◆D◆ BOLT TIGHTENING

- (1) Apply automatic transmission fluid to the bolts and tighten the bolts to the specified torque in the sequence shown in the illustration.

LOW-REVERSE BRAKE DISASSEMBLY AND REASSEMBLY

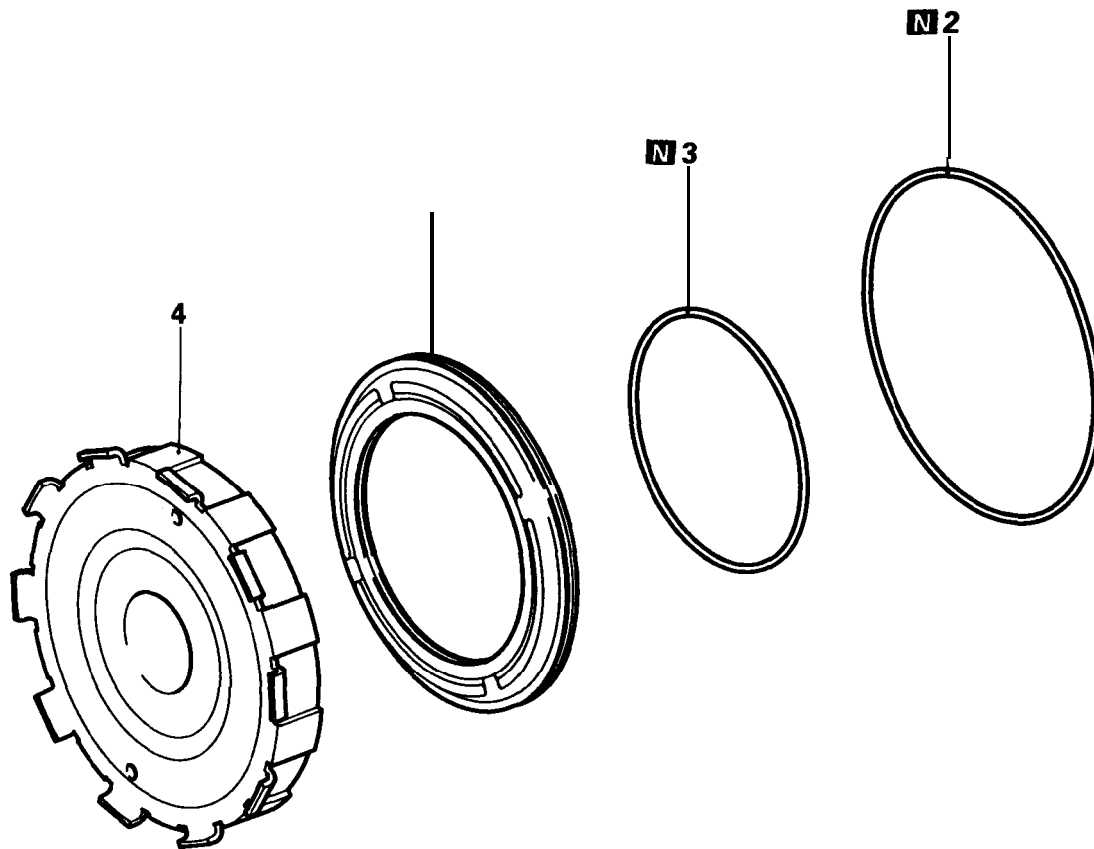

Disassembly steps

1. Low-reverse brake piston
2. D-ring
3. D-ring
4. Center support

TFA0386

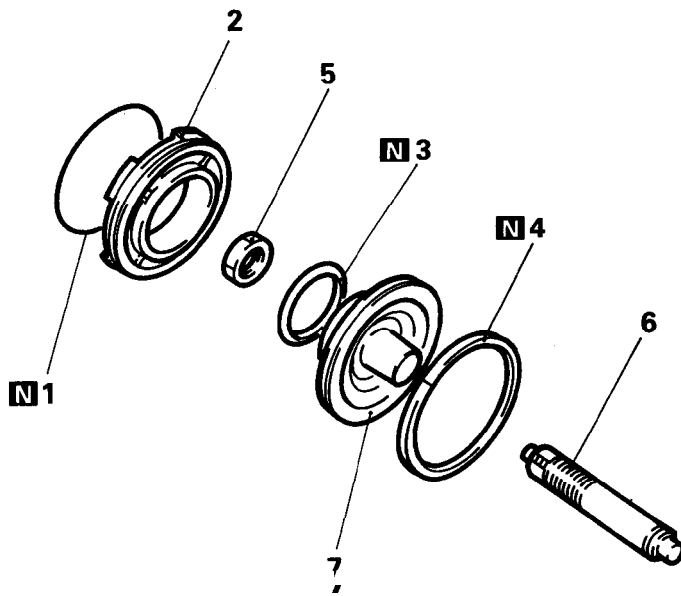
KICKDOWN SERVO**DISASSEMBLY AND REASSEMBLY****Disassembly steps**

1. O-ring
2. Kickdown servo sleeve
- 3.
4. Seal D-ring ring
5. Locknut
6. Kickdown servo rod
7. Kickdown servo piston

1750299

SPEEDOMETER GEAR

DISASSEMBLY AND REASSEMBLY

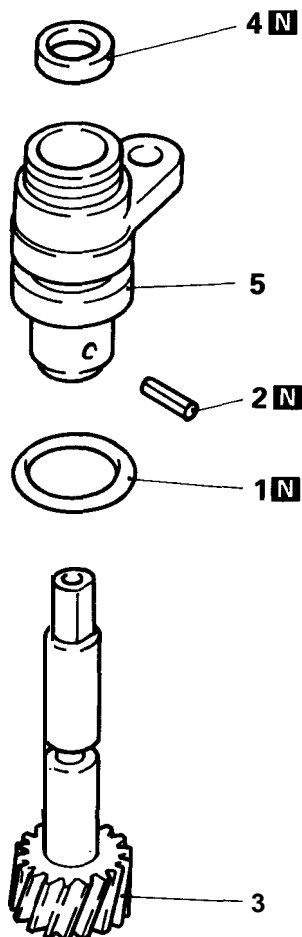

Disassembly steps

1. O-ring
- ▶▶▶ 2. Spring pin
3. Driven gear
4. Oil seal
5. Sleeve

201078

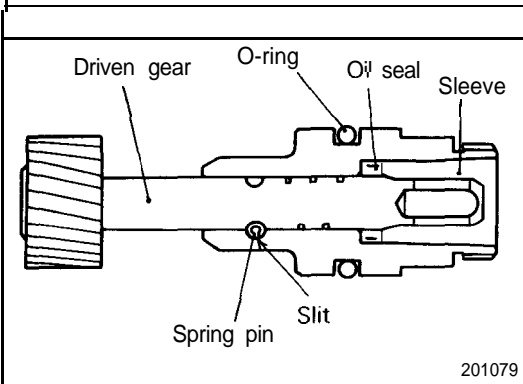

201079

REASSEMBLY SERVICE POINT

▶▶▶ SPRING PIN INSTALLATION

- (1) Drive a new spring pin into the sleeve. Make sure that the slit in the spring pin does not face the gear.

**DRIVE SHAFT OIL SEAL
DISASSEMBLY AND REASSEMBLY**

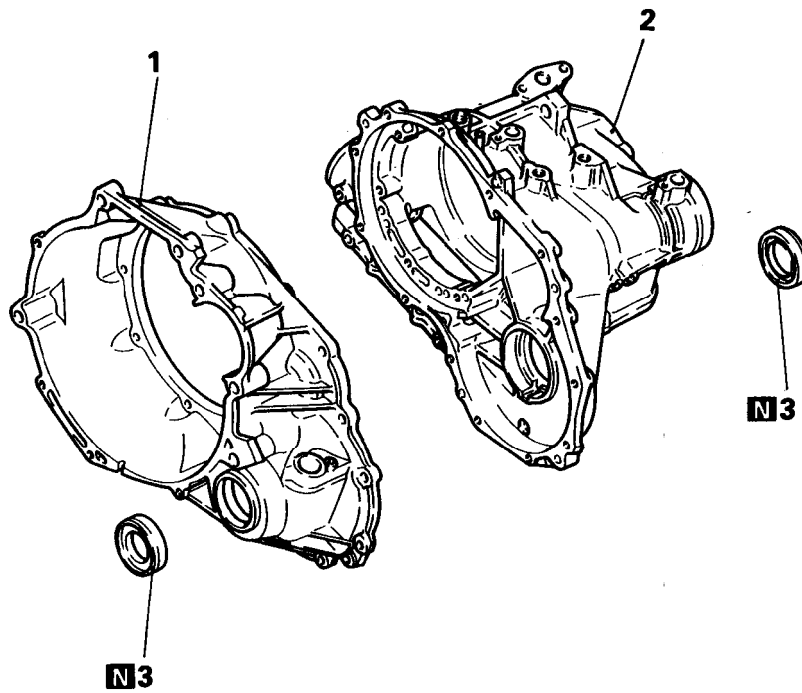

Disassembly steps

1. Converter housing
2. Transmission case
- ▶▶▶ 3. Oil seal

1750298

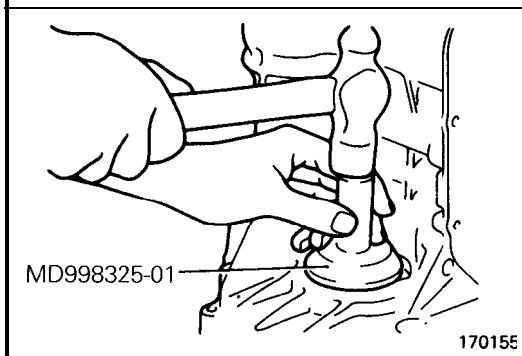

REASSEMBLY SERVICE POINT

▶▶▶ OIL SEAL INSTALLATION

TRANSFER SHAFT

DISASSEMBLY AND REASSEMBLY

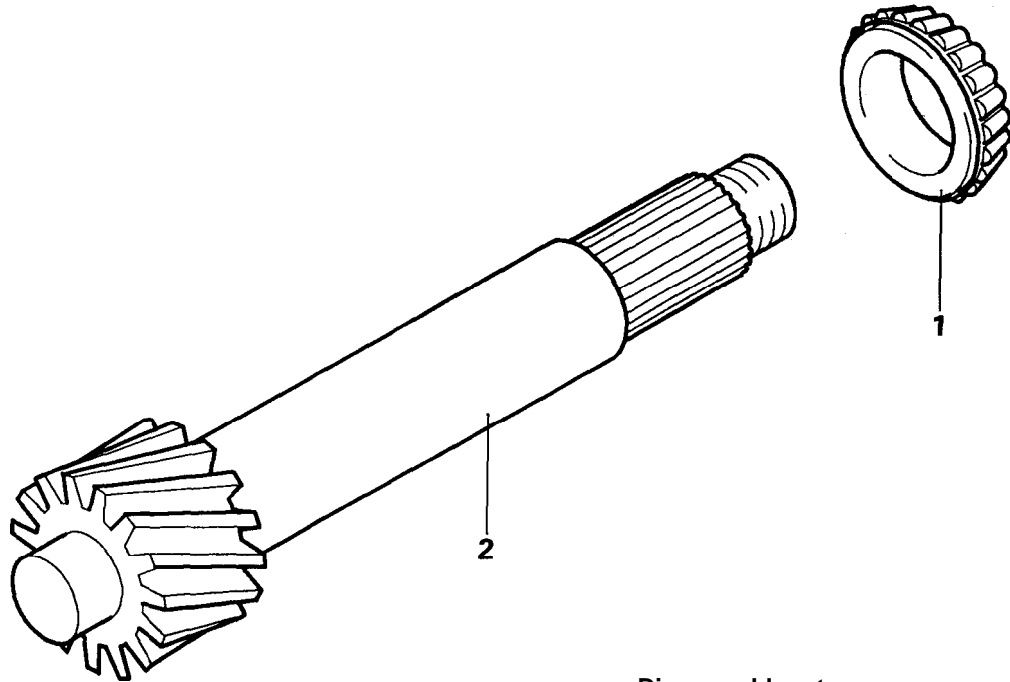

Disassembly steps

- ◆A◆ 1. Bearing
- 2. Transfer shaft

TFA0656

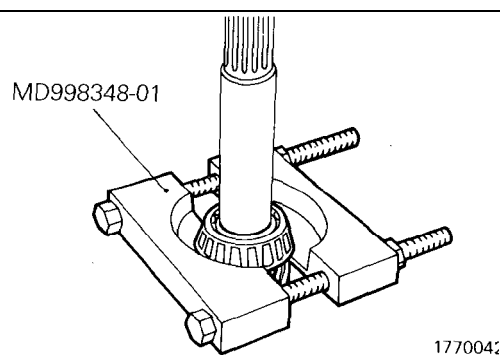

177004z

DISASSEMBLY SERVICE POINT

◆A◆ BEARING REMOVAL

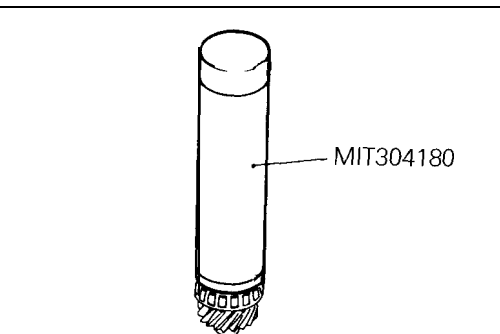

TFA0507

TRANSFER DRIVEN GEAR DISASSEMBLY AND REASSEMBLY

1770043
TFA0509

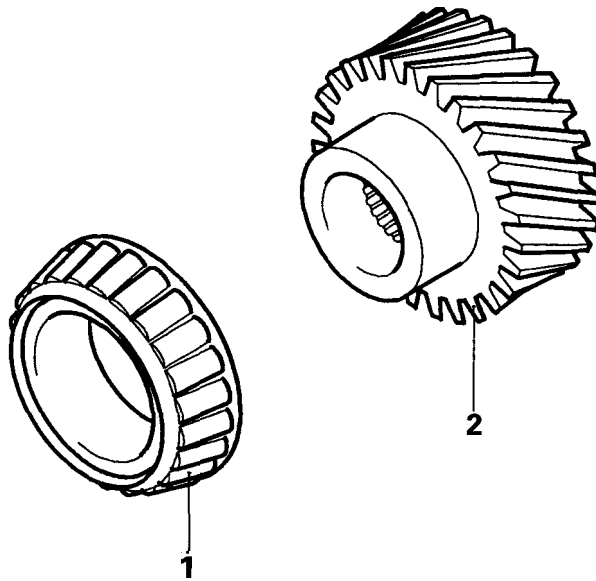

Disassembly steps

- ◁A▷ ▷A◁ 1. Bearing
- 2. Transfer driven gear

TFA0657

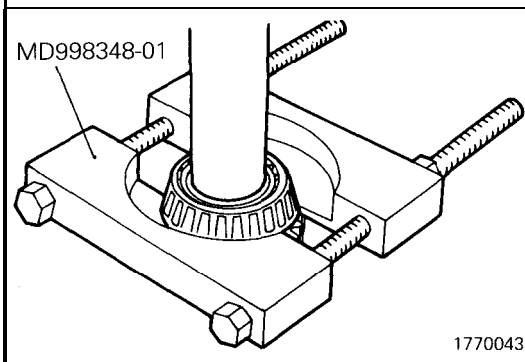

DISASSEMBLY SERVICE POINT

◁A▷ BEARING REMOVAL

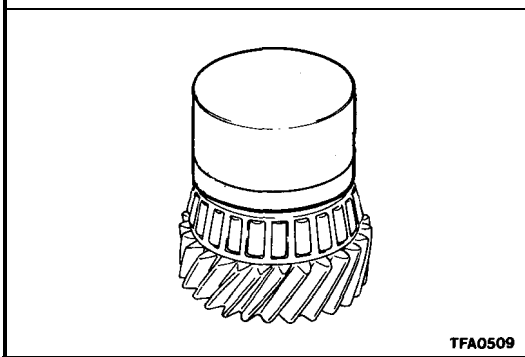

REASSEMBLY SERVICE POINT

▷A◁ BEARING INSTALLATION

VALVE BODY

DISASSEMBLY AND REASSEMBLY

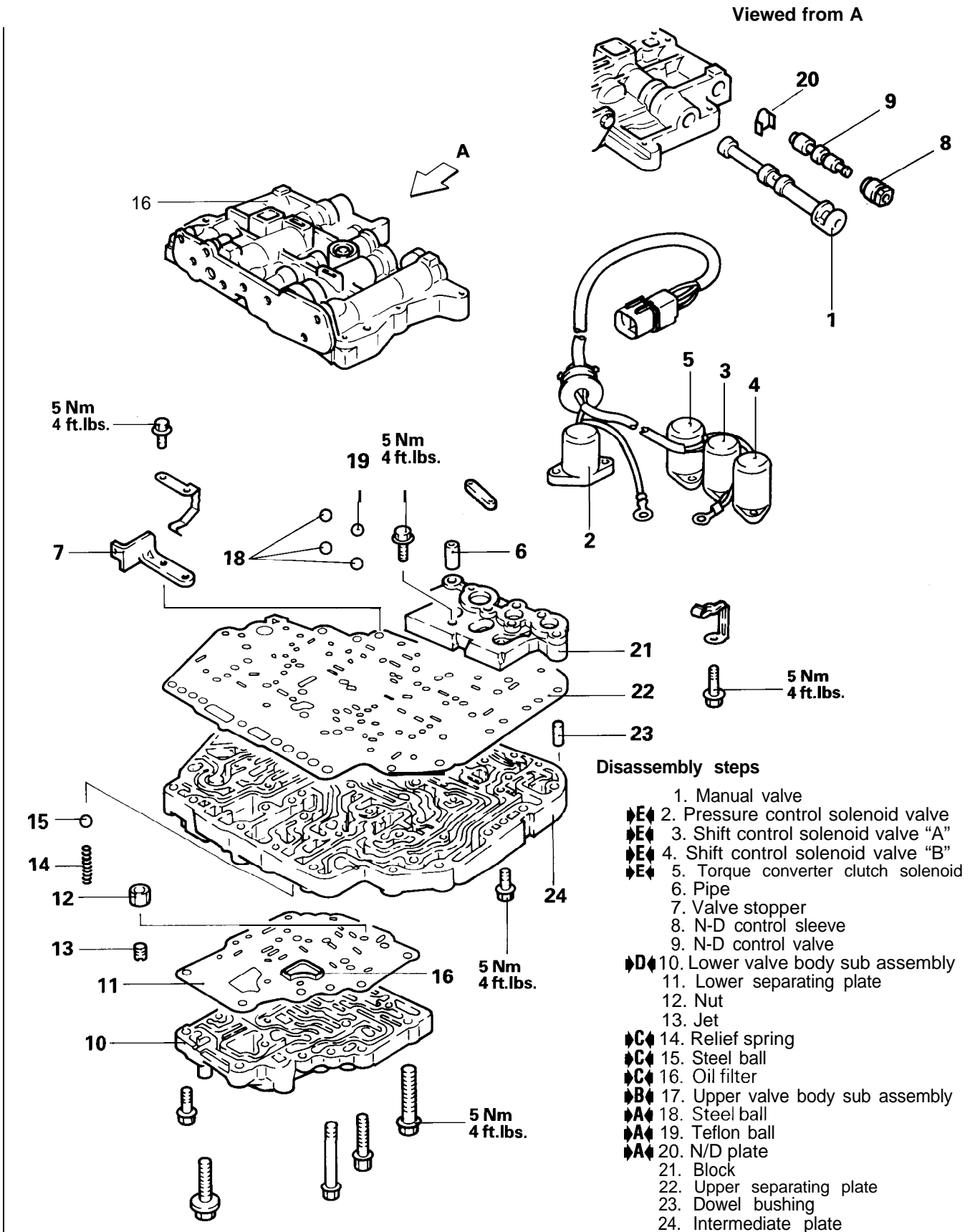

Disassembly steps

1. Manual valve
- ▶E 2. Pressure control solenoid valve
- ▶E 3. Shift control solenoid valve "A"
- ▶E 4. Shift control solenoid valve "B"
- ▶E 5. Torque converter clutch solenoid
6. Pipe
7. Valve stopper
8. N-D control sleeve
9. N-D control valve
- ▶D 10. Lower valve body sub assembly
11. Lower separating plate
12. Nut
13. Jet
- ▶C 14. Relief spring
- ▶C 15. Steel ball
- ▶C 16. Oil filter
- ▶B 17. Upper valve body sub assembly
- ▶A 18. Steel ball
- ▶A 19. Teflon ball
- ▶A 20. N/D plate
21. Block
22. Upper separating plate
23. Dowel bushing
24. Intermediate plate

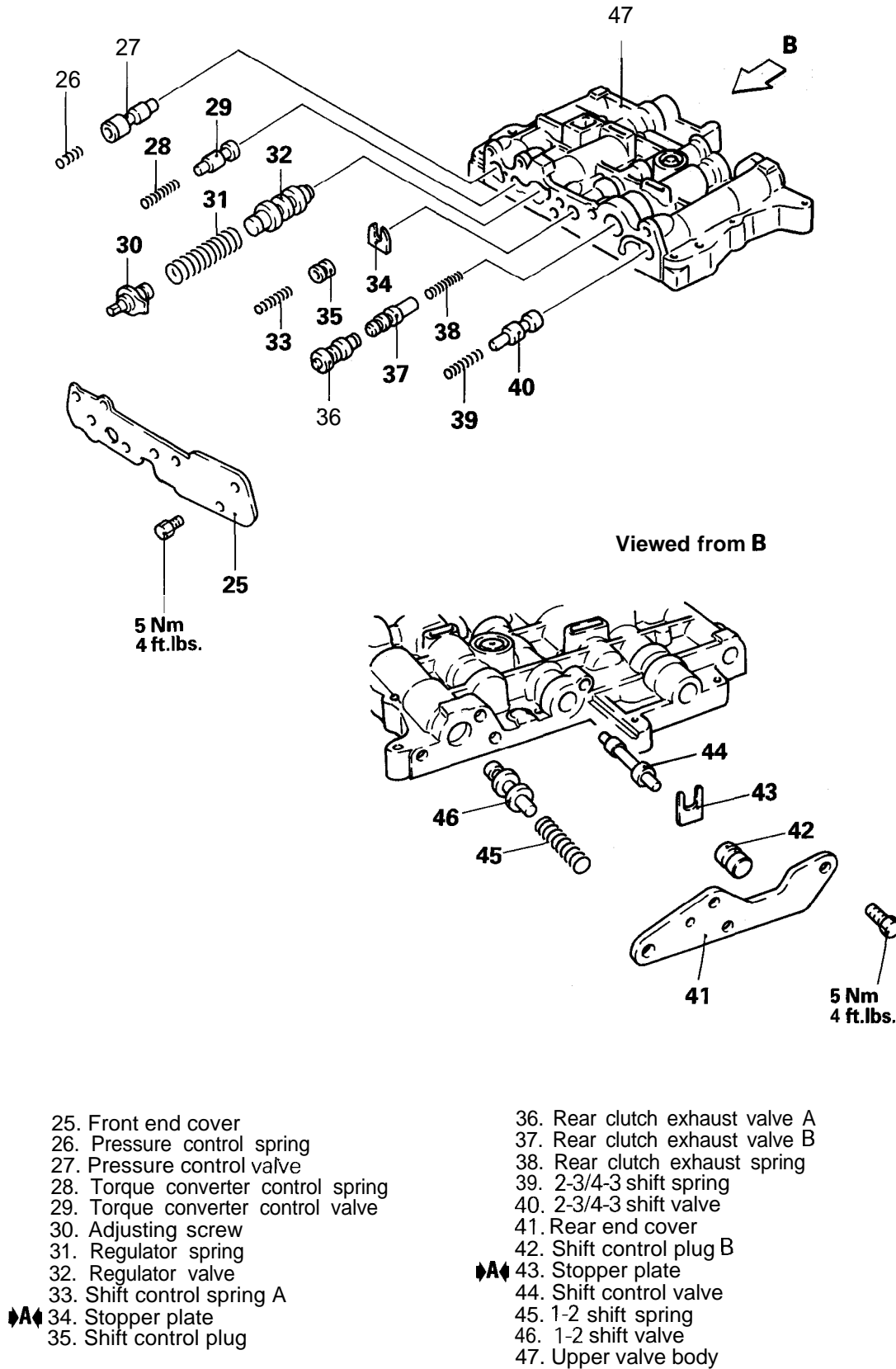

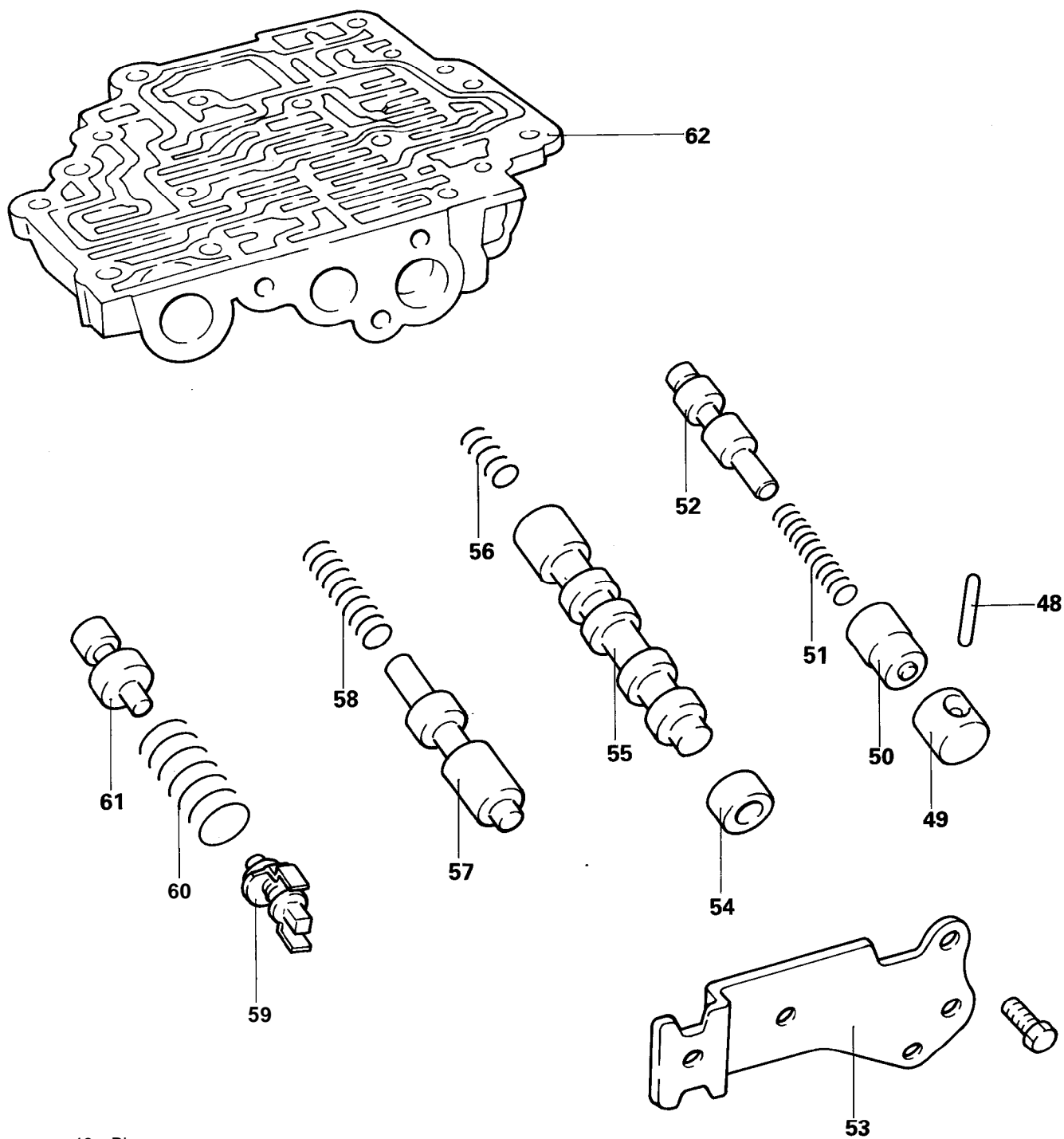

- 48. Pin
- 49. Stopper
- 50. End clutch plug
- 51. End clutch spring
- 52. End clutch valve
- 53. End cover
- 54. Torque converter clutch control sleeve
- 55. Torque converter clutch control valve
- 56. Torque converter clutch control spring
- 57. N-R control valve
- 58. N-R control spring
- 59. Adjusting screw
- 60. Reducing spring
- 61. Reducing valve
- 62. Lower valve body

TFA054 1

TFA0541

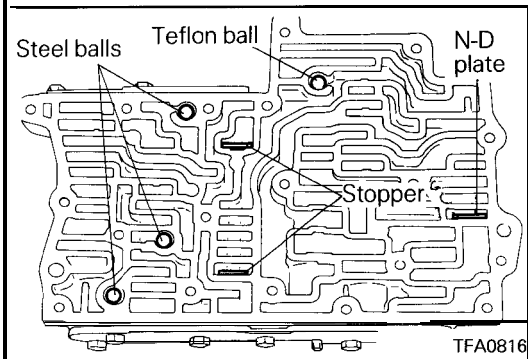

TFA0816

REASSEMBLY SERVICE POINTS

▶A◀ STOPPER PLATE / N-D PLATE / TEFLON BALL / STEEL BALL LOCATION

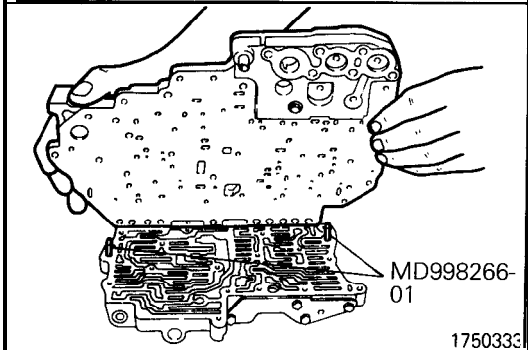

1750333

▶B◀ UPPER VALVE BODY SUB ASSEMBLY INSTALLATION

- (1) Mount the special tools, and secure the upper separating plate and intermediate plate with the eight mounting-bolts. Then, demount the special tools.

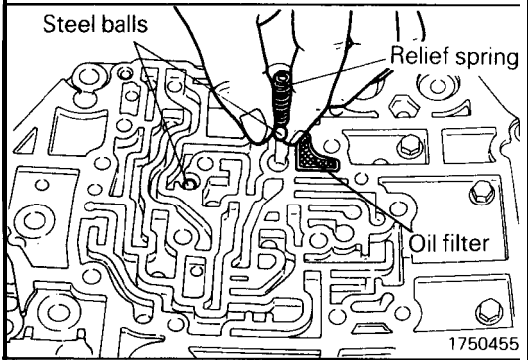

1750455

▶C◀ OIL FILTER / STEEL BALL / RELIEF SPRING LOCATION

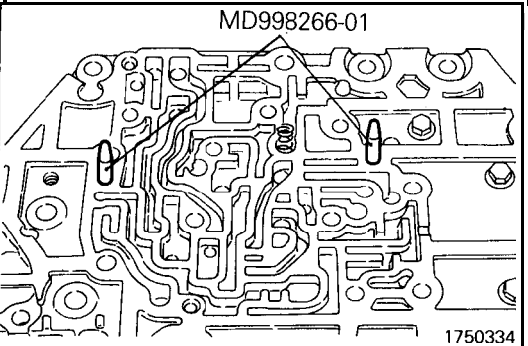

1750334

▶D◀ LOWER VALVE BODY SUB ASSEMBLY INSTALLATION

- (1) Mount the special tools on the intermediate plate.

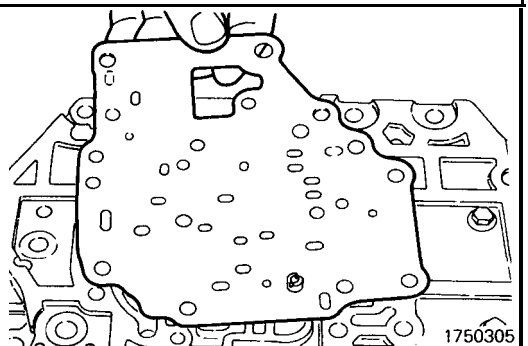

1750305

- (2) Install the separating plate.

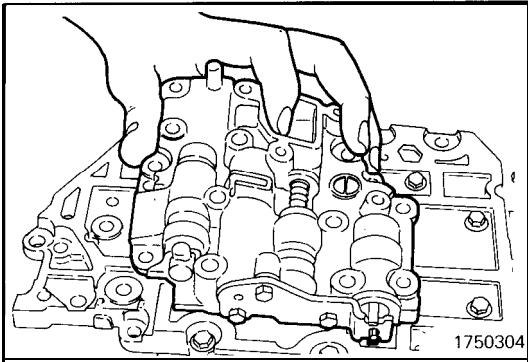

(3) Secure the lower valve body with the bolts. Then, remove the special tools.

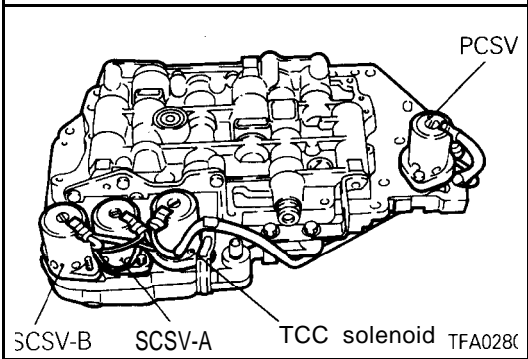

SOLENOID VALVE ASSEMBLY INSTALLATION

(1) Install each solenoid valve in the position shown in the figure.

Solenoid valve	Wiring color
Shift control solenoid valve "A" (SCSV-A)	Orange
Shift control solenoid valve "B" (SCSV-B)	Yellow
Torque converter clutch solenoid (TCC solenoid)	Red <MODEL 1992 and MODEL 1993 – E33A, D21 A, D22A>
	Red/Black <MODEL 1993 – CB5A, N11W, N14W, N34W>
Pressure control solenoid valve (PCSV)	Blue

AUTOMATIC TRANSAXLE

F4A33, W4A32, W4A33

CONTENTS

ANNULUS GEAR AND TRANSFER		SPECIFICATIONS	9
DRIVE GEAR SET	100	Adjustment Pressure Plate, Snap Rings and Spacers	11
CENTER DIFFERENTIAL – 4WD	115	Gear Ratio Table	9
DIFFERENTIAL	102	Sealants and Adhesives	17
END CLUTCH	94	Service Specifications	10
EXTENSION HOUSING – 4WD	130	Torque Specifications	18
FRONT CLUTCH	86	Transaxle Model Table	9
FRONT OUTPUT SHAFT – 4WD	118	Valve Body Spring Identification Chart	10
GENERAL INFORMATION	2	SPEEDOMETER GEAR	107
KICKDOWN SERVO	105	TRANSAXLE – 4WD	52
LOW-REVERSE BRAKE	106	TRANSAXLE – FWD	23
OIL PUMP	84	TRANSFER – 4WD	119
OIL PUMP DRIVE GEAR – F4A-33-1-MNN5, MNPE	131	TRANSFER CASE – 4WD	127
PLANETARY GEAR	96	TRANSFER CASE ADAPTER – 4WD	124
REAR CLUTCH	90	TRANSFER SHAFT – FWD	113
SPECIAL TOOLS	19	VALVE BODY	108

GENERAL INFORMATION

Precautions to be taken when disassembling and reassembling the transaxle

- Because the automatic transaxle is composed of component parts of an especially high degree of precision, these parts should be very carefully handled during disassembly and assembly so as not to scar or scratch them.
- A rubber mat should be placed on the workbench, and it should always be kept clean.
- During disassembly, cloth gloves or shop towels should not be used. If such items must be used, either use articles made of nylon, or use paper towels.
- All disassembled parts must be thoroughly cleaned.
Metal parts may be cleaned with ordinary detergents, but must be thoroughly air dried.
- Clean the clutch disc, resin thrust plate and rubber parts by using ATF (automatic transaxle fluid), being very careful that dust, dirt, etc. do not adhere to them.
- Do not reuse gaskets, oil seals, or rubber parts.
Replace such parts with new ones at every reassembly. The O-ring of the oil level gauge need not be replaced.
- Do not use grease other than petrolatum jelly.
- Apply ATF to friction components, rotating parts, and sliding parts before installation.
- A new clutch disc should be immersed in ATF for at least two hours before installation.
- Do not apply sealer or adhesive to gaskets.
- When a bushing must be replaced, replace the assembly in which it is incorporated.
- If the transaxle main unit is damaged, also disassemble and clean the cooler system.

SECTIONAL VIEW – F4A33 with torque converter clutch

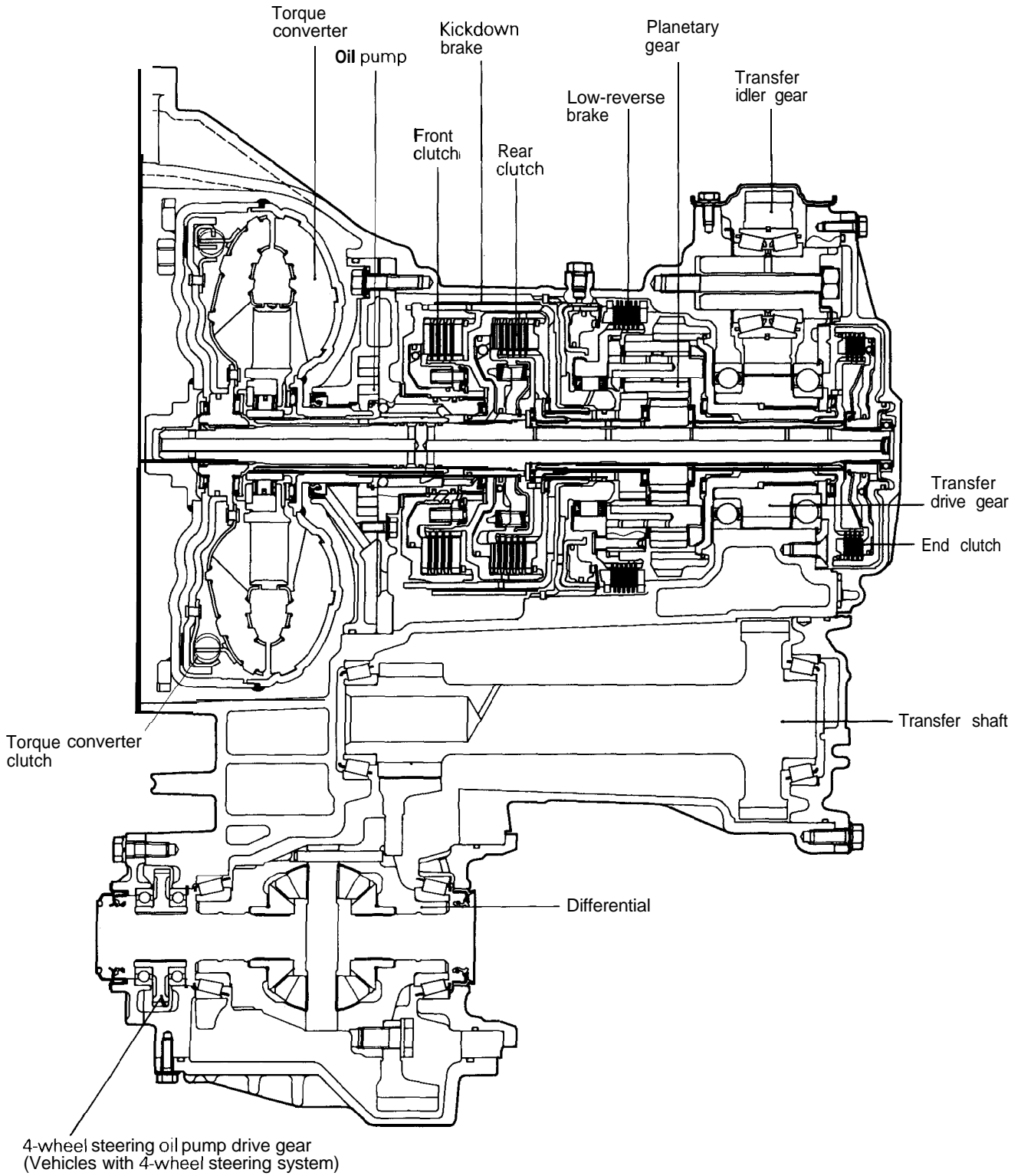

SECTIONAL VIEW – F4A33 without torque converter clutch

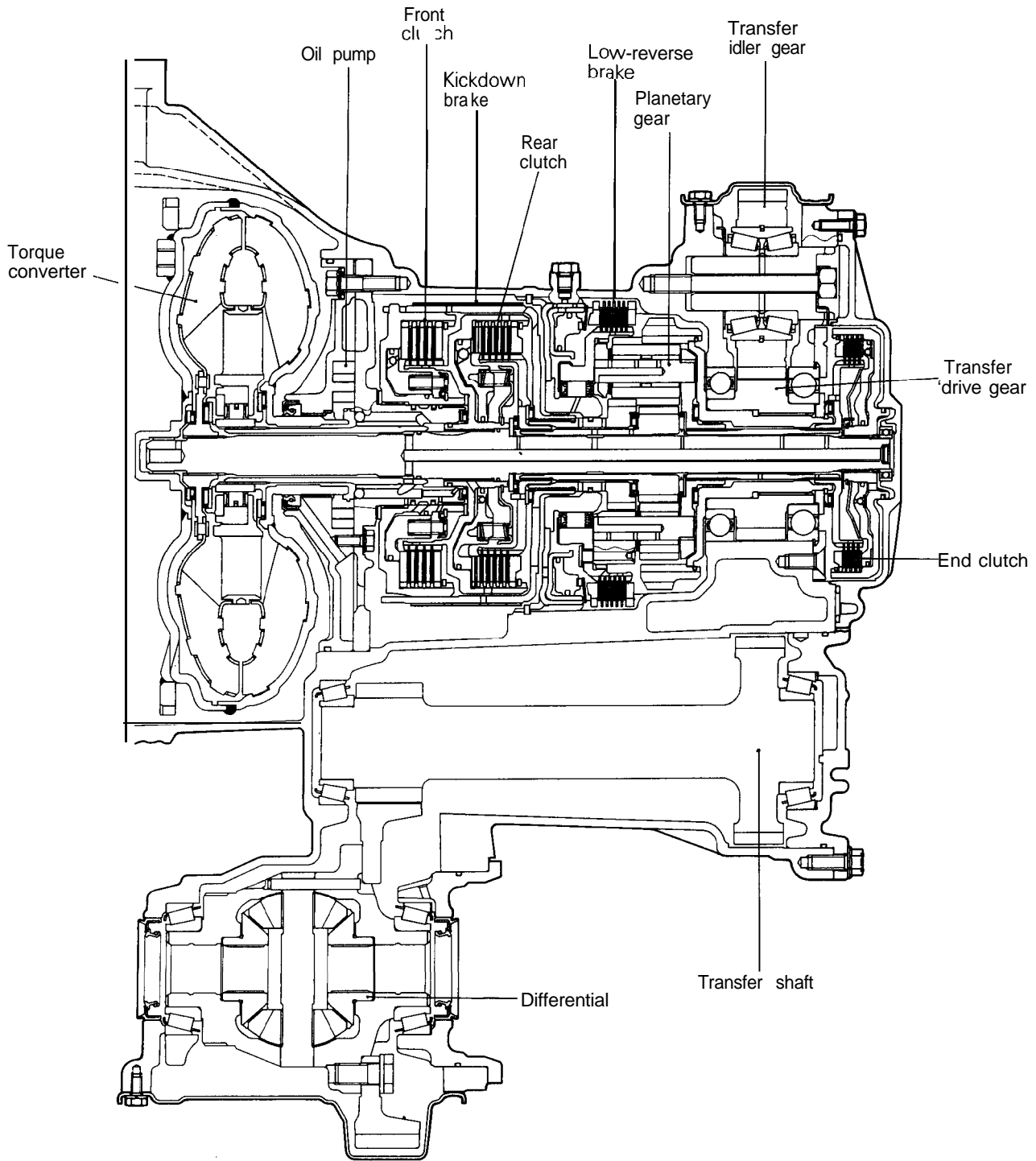

SECTIONAL VIEW – W4A32 with torque converter clutch

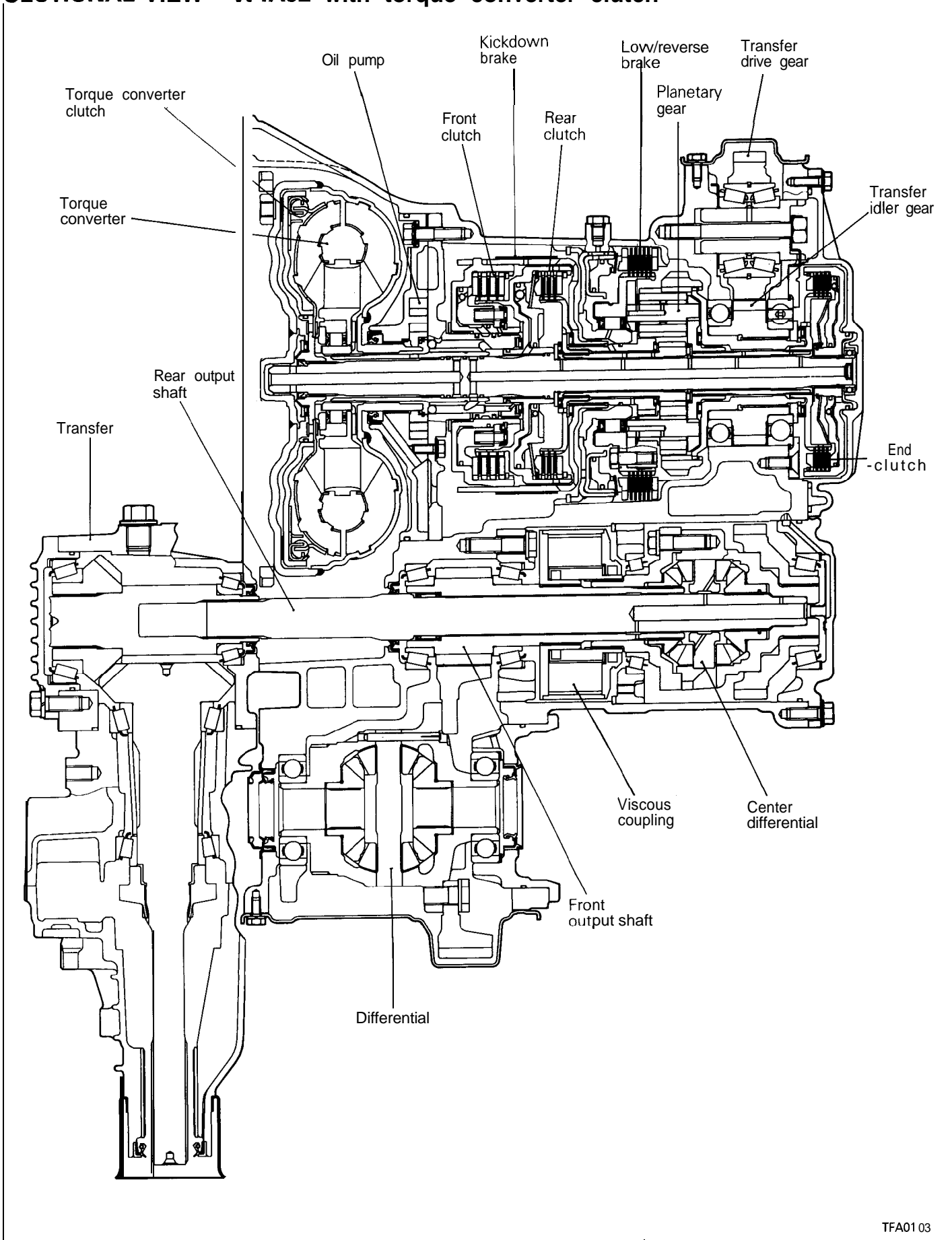

SECTIONAL VIEW – W4A33 without torque converter clutch

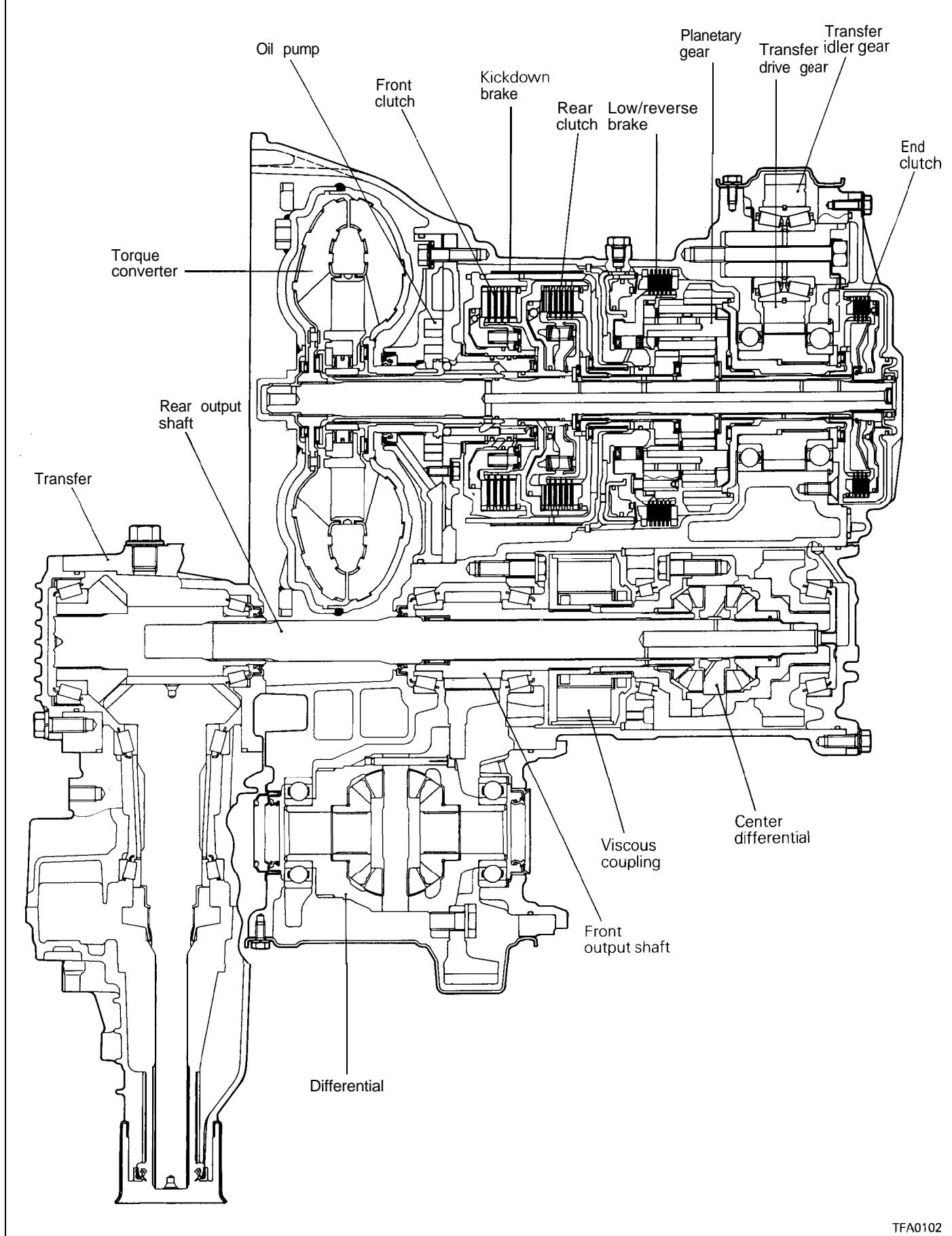

HYDRAULIC CONTROL SYSTEM (With torque converter clutch)

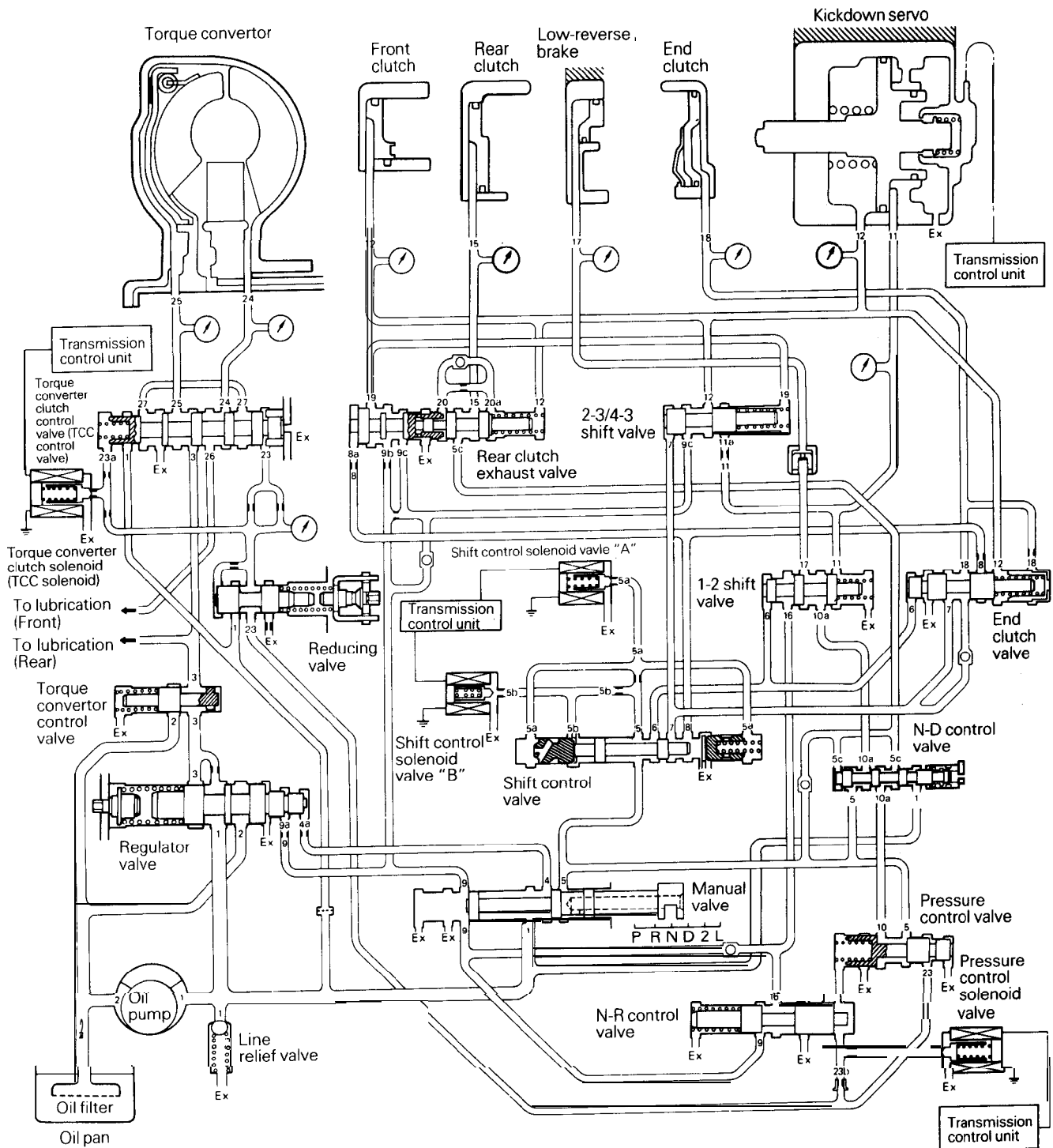

HYDRAULIC CONTROL SYSTEM (Without torque converter clutch)

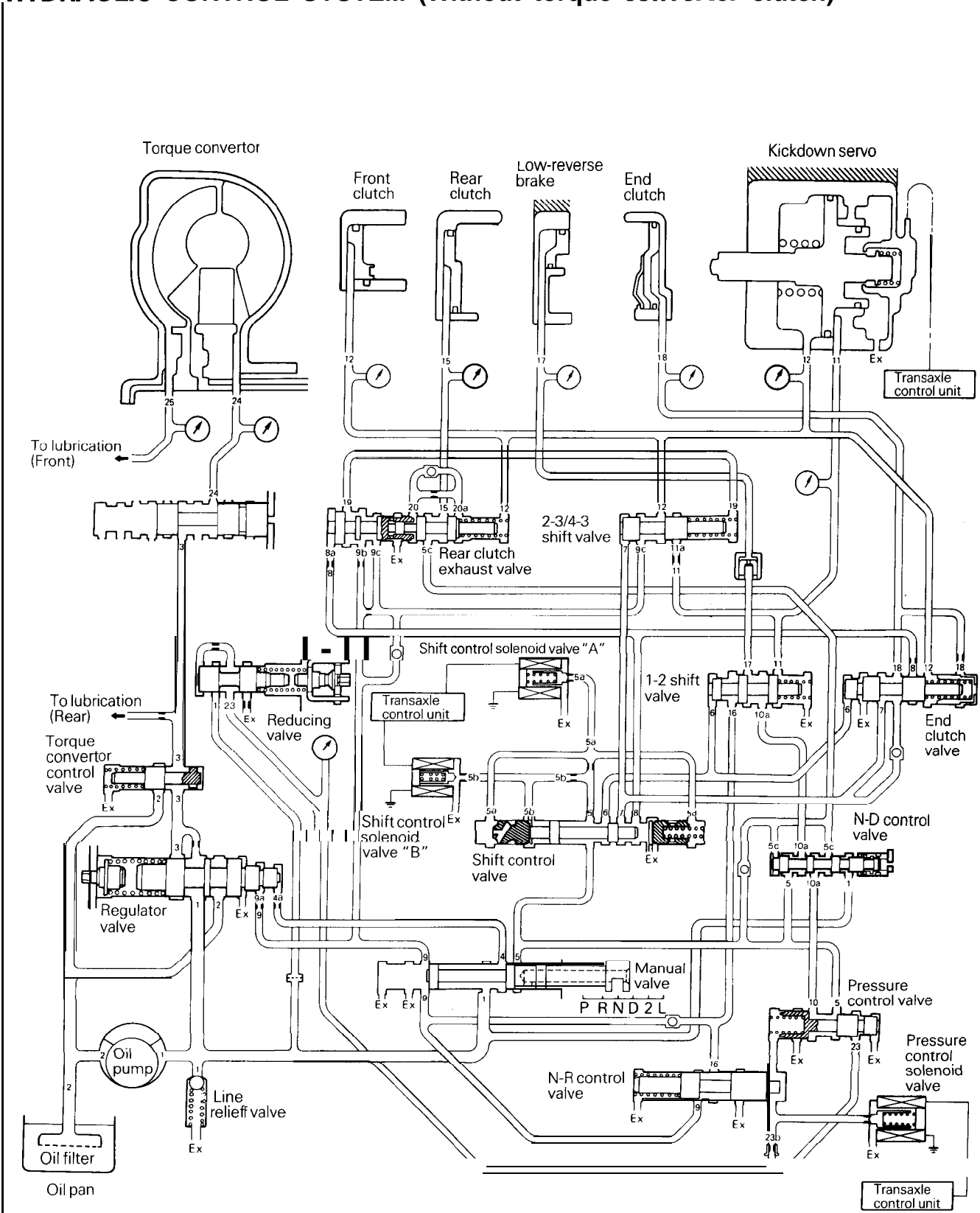

SPECIFICATIONS

TRANSAXLE MODEL TABLE – MODEL 1992

Transaxle model	Gear ratio type	Speedometer gear ratio	Final gear ratio	Vehicle model	Engine model
F4A33-1-UP61* ¹	A	29/36	4.376	D22A	4G63-DOHC TIC
MNP2	A	28/36	3.958	Z11A	6G72-DOHC
MNN3	A	28/36	3.958	F16A	6G72
MNN4	A	28/36	3.958	F16A	6G72-DOHC
MNN5* ²	A	28/36	3.958	F16A	6G72-DOHC
W4A32-1-UNN	A	28/36	4.422	N44W	4G64
WNA	B	28/36	4.750	N21W	4G93
UQA2	B	30/36	4.422	E38A	4G63-DOHC
W4A33-1-UP6* ¹	A	29/36	4.422	D27A	4G63-DOHC TIC

TRANSAXLE MODEL TABLE – MODEL 1993

Transaxle model	Gear ratio type	Speedometer gear ratio	Final gear ratio	Vehicle model	Engine model
F4A33-1-UP61* ¹	A		4.376	D22A	4G63-DOHC T/C
MNP8	A	29/3628/36	3.958	Z11A	6G72-DOHC
MNP9	A		3.958	F16A	6G72
MNPC	A	28/3628/36	3.958	F16A	6G72-DOHC
MNPE* ²	A	28/36	3.958	F16A	6G72-DOHC
W4A32-1-UNQ	B	28/36	4.422	N24W, N44W	4G64
WNF1	A	29/3628/36	4.750	N21W	4G93
W4A33-1-UP61* ¹			4.422	D27A	4G63-DOHC TIC

NOTE

*1: Model without torque converter clutch (TCC)

*2: Model with 4-wheel steering oil pump drive gear

GEAR RATIO TABLE

	A	B
1 st	2.551	2.846
2nd	1.488	1.581
3rd	1.000	1.000
4th	0.685	0.685
Reverse	2.176	2.176

SERVICE SPECIFICATIONS

mm (in.)

Item	Standard
Transfer driven gear preload (Center differential case preload)	0.075 – 0.135 (.0030 – .0053)
Low-reverse brake end play	1.0 – 1.2 (.0394 – .0472)
Input shaft end play	0.3 – 1.0 (.0118 – .0394)
Differential case preload – F4A33	0.075 – 0.135 (.0030 – .0053)
Front differential case end play – W4A32, W4A33	0.045 – 0.165 (.0018 – .0065)
Differential gear and pinion backlash	0.025 – 0.150 (.0010 – .0059)
Oil pump side clearance	0.03 – 0.05 (.0012 – .0020)
Output flange bearing end play	0 – 0.09 (0 – .0035)
Front clutch end play – F4A33, W4A33	0.8 – 1.0 (.0315 – .0394)
– F4A32	0.7 – 0.9 (.0276 – .0354)
Rear clutch end play – F4A33, W4A33	1.0 – 1.2 (.0394 – .0472)
– F4A32	0.4 – 0.6 (.0157 – .0236)
End clutch end play	0.60 – 0.85 (.0236 – .0335)
Transfer drive gear end play	0 – 0.09 (0 – .0035)
Front output shaft preload – W4A32, W4A33	0.055 – 0.115 (.0022 – .0045)
Center differential side gear end play- W4A32, W4A33	0.01 – 0.03 (.0004 – .0012)
Bevel gear set backlash – W4A32, W4A33	0.08 – 0.13 (.0031 – .0051)
Driven bevel gear turning drive torque – W4A32, W4A33 Nm (ft.lbs)	1.0 – 1.7 (.72 – 1.23)
Drive bevel gear shaft turning drive torque – W4A32, W4A33 Nm (ft.lbs)	1.7 – 2.5 (1.23 – 1.81)

VALVE BODY SPRING IDENTIFICATION CHART

mm (in.)

Part name	Wire diameter	Outside diameter	Length	No. of turns
Regular valve spring	1.4 (.055)	15 (.59)	52 (2.05)	11.5
1-2 shift valve spring	0.6 (.024)	7.6 (.299)	26.6 (1.047)	13.5
Pressure control valve spring	0.45 (.0177)	7.6 (.299)	21.3 (.839)	8.5
Rear clutch exhaust valve spring	0.7 (.028)	6.8 (.268)	27.4 (1.079)	12.5
End clutch valve spring	0.6 (.024)	6.6 (.260)	24.4 (.961)	15.5
2-3 shift valve spring	0.8 (.031)	7.0 (.276)	27.5 (1.083)	15.5
N-R control valve spring	0.7 (.028)	9.2 (.362)	32.1 (1.264)	8.5
Reducing valve spring	1.2 (.047)	8.9 (.350)	29.5 (1.161)	12.5
Line relief spring	1.0 (.039)	7.0 (.276)	17.3 (.681)	10
Torque converter valve spring	1.3 (.051)	9.0 (.354)	22.6 (.890)	3.5
Shift control valve spring	0.5 (.020)	5.7 (.224)	26.8 (1.055)	22
Torque converter clutch control valve spring	0.7 (.028)	6.2 (.244)	14.2 (.559)	3.5

ADJUSTMENT PRESSURE PLATE, SNAP RINGS AND SPACERS

Part name	Thickness mm (in.)	Identification symbol	Part No.
Pressure plate – F4A33, W4A33 (For adjustment of low-reverse brake end play)	5.9 (.232)	A	MD731 736
	6.0 (.236)	0	MD731 737
	6.1 (.240)	1	MD731 738
	6.2 (.244)	2	MD731 739
	6.3 (.248)	3	MD731740
	6.4 (.252)	4	MD731 588
	6.5 (.256)	5	MD731 741
	6.6 (.260)	6	MD731 742
	6.7 (.264)	7	MD731743
	6.8 (.268)	8	MD731 744
6.9 (.272)	9	MD731 745	
Pressure plate – W4A32 (For adjustment of low-reverse brake end play)	5.6 (.220)	Y	MD731 720
	5.7 (.224)	Z	MD731721
	5.8 (.228)	8	MD727801
	5.9 (.232)	9	MD731000
	6.0 (.236)	0	MD727802
	6.1 (.240)	1	MD731001
	6.2 (.244)	2	MD727803
	6.3 (.248)	3	MD731 002
	6.4 (.252)	4	MD727804
	6.5 (.256)	5	MD731003
	6.6 (.260)	6	MD727805
	6.7 (.264)	7	MD731 004
	6.8 (.268)	X	MD731 005
6.9 (.272)	A	MD734766	
7.0 (.276)	B	MD734767	
Snap ring – F4A33, W4A33 For adjustment of front clutch and rear clutch only	1.3" (.051)	None	MD731747
	1.4" (.055)	Blue	MD731748
	1.5 (.059)	Brown	MD731749
	1.6 (.063)	None	MD731750
	1.7 (.067)	Blue	MD731 751
	1.8 (.071)	Brown	MD731 752
	1.9 (.075)	None	MD731 753
	2.0 (.079)	Blue	MD731 754
	2.1 (.083)	Brown	MD731 755
	2.2 (.087)	None	MD731 756
	2.3 (.091)	Blue	MD731 757
2.4 (.094)	Brown	MD731 758	
Snap ring (For adjustment of end clutch end play)	1.05 (.0413)	White	MD71 5800
	1.30 (.0512)	Yellow	MD715801
	1.55 (.0610)	None	MD71 5802
	1.80 (.0709)	Green	MD71 5803
	2.05 (.0807)	Pink	MD720849

Part name	Thickness mm (in.)	Identification symbol	Part No.
Snap ring – W4A32 (For adjustment of front clutch and rear clutch end play)	1.6 (.063)	None	MD955630
	1.7 (.067)	Brown	MD730930
	1.8 (.071)	Blue	MD955631
	1.9 (.075)	None	MD730931
	2.0 (.079)	Brown	MD955632
	2.1 (.083)	Blue	MD730932
	2.2 (.087)	None	MD955633
	2.3 (.091)	Brown	MD730933
	2.4 (.094)	Blue	MD955634
	2.5 (.098)	None	MD730934
	2.6 (.102)	Brown	MD955635
	2.7 (.106)	Blue	MD730935
	2.8 (.110)	None	MD955636
	2.9 (.114)	Brown	MD730936
3.0 (.118)	Blue	MD955637	
Spacer – F4A33 (D22A), W4A32, W4A33 (For adjustment of transfer driven gear preload)	0.62 (.0244)	62	MD737444
	0.65 (.0256)	65	MD737445
	0.68 (.0268)	68	MD737446
	0.71 (.0280)	71	MD737447
	0.74 (.0291)	74	MD728802
	0.77 (.0303)	77	MD728803
	0.80 (.0315)	80	MD728804
	0.83 (.0327)	83	MD728805
	0.86 (.0339)	86	MD728806
	0.89 (.0350)	89	MD728807
	0.92 (.0362)	92	MD728808
	0.95 (.0374)	95	MD728809
	0.98 (.0386)	98	MD728810
	1.01 (.0398)	01	MD728811
	1.04 (.0409)	04	MD728812
	1.07 (.0421)	07	MD728813
	1.10 (.0433)	10	MD728814
	1.13 (.0445)	13	MD728815
	1.16 (.0457)	16	MD728816
1.19 (.0469)	19	MD728817	
1.22 (.0480)	22	MD728818	
1.25 (.0492)	25	MD728819	
1.28 (.0504)	28	MD728820	
1.31 (.0516)	31	MD728821	

Part name	Thickness mm (in.)	Identification symbol	Part No.
Spacer – F4A33 (Z11A, F16A) (For adjustment of transfer driven gear preload)	0.62 (.0244)	62	MD740866
	0.65 (.0256)	65	MD740867
	0.68 (.0268)	68	MD740868
	0.71 (.0280)	71	MD740869
	0.74 (.0291)	74	MD740870
	0.77 (.0303)	77	MD740871
	0.80 (.0315)	80	MD740872
	0.83 (.0327)	83	MD740873
	0.86 (.0339)	86	MD740874
	0.89 (.0350)	89	MD740875
	0.92 (.0362)	92	MD740876
	0.95 (.0374)	95	MD740877
	0.98 (.0386)	98	MD740878
	1.01(.0398)	01	MD740879
	1.04 (.0409)	04	MD740880
	1.07 (.0421)	07	MD740881
	1.10(.0433)	10	MD740882
	1.13(.0445)	13	MD740883
	1.16 (.0457)	16	MD740884
	1.19(.0469)	19	MD740885
1.22 (.0480)	22	MD740886	
1.25 (.0492)	25	MD740887	
1.28 (.0504)	28	MD740888	
1.31 (.0516)	31	MD740889	
Snap ring For adjustment of output flange (bearing end play)	1.76 (.0693)	Brown	MD733314
	1.82 (.0717)	None	MD722538
	1.88 (.0740)	Blue	MD721014
	1.94 (.0764)	Brown	MD721015
	2.00 (.0787)	None	MD721016
	2.06 (.0811)	Blue	MD721017
	2.12 (.0835)	Brown	MD722539
	2.18 (.0858)	None	MD733315

Part name	Thickness mm (in.)	Identification symbol	Part No.
Spacer – F4A33(D22A) preload adjustment of differential case	0.71 (.0280)	71	MD754475
	0.74 (.0291)	74	MD727660
	0.77 (.0303)	77	MD754476
	0.80 (.0315)	80	MD727661
	0.83 (.0327)	83	MD720937
	0.86 (.0339)	86	MD720938
	0.89 (.0350)	89	MD720939
	0.92 (.0362)	92	MD720940
	0.95 (.0374)	95	MD720941
	0.98 (.0386)	98	MD720942
	1.01 (.0398)	01	MD720943
	1.04 (.0409)	04	MD720944
	1.07 (.0421)	07	MD720945
	1.10 (.0433)	J	MD71 0454
	1.13 (.0445)	D	MD700270
	1.16 (.0457)	K	MD710455
	1.19 (.0469)	L	MD71 0456
	1.22 (.0480)	G	MD700271
	1.25 (.0492)	M	MD71 0457
	1.28 (.0504)	N	MD710458
1.31 (.0516)	E	MD706574	
1.34 (.0528)	O	MD71 0459	
1.37 (.0539)	P	MD71 0460	
Spacer – F4A33(Z11 A, F16A) preload adjustment of differential case	0.71 (.0280)	71	MD754446
	0.74 (.0291)	74	MD754447
	0.77 (.0303)	77	MD754448
	0.80 (.0315)	80	MD754449
	0.83 (.0327)	83	MD740846
	0.86 (.0339)	86	MD740847
	0.89 (.0350)	89	MD740848
	0.92 (.0362)	92	MD740849
	0.95 (.0374)	95	MD740850
	0.98 (.0386)	98	MD740851
	1.01 (.0398)	01	MD740852
	1.04 (.0409)	04	MD740853
	1.07 (.0421)	07	MD740854
	1.10 (.0433)	10	MD740855
	1.13 (.0445)	13	MD740856
	1.16 (.0457)	16	MD740857
	1.19 (.0469)	19	MD740858
	1.22 (.0480)	22	MD740859
	1.25 (.0492)	25	MD740860
	1.28 (.0504)	28	MD740861
1.31 (.0516)	31	MD740862	
1.34 (.0528)	34	MD740863	
1.37 (.0539)	37	MD740864	

Part name	Thickness mm (in.)	Identification symbol	Part No.
Spacer – W4A32, W4A33 (For adjustment of differential case end play)	1.01 (.0398)	01	MD720943
	1.10 (.0433)	J	MD710454
	1.19 (.0469)	L	MD71 0456
	1.28 (.0504)	N	MD71 0458
Spacer (For adjustment of differential gear and pinion backlash)	0.75 – 0.82 (.0295 – .0323)	—	MD722986
	(.0327 – .0362)	—	MD722985
	0.93 – 1.00 (.0366 – .0394)	—	MD722984
	1.01 -1.08 (.0398 – .0425)	—	MD722982
	1.09 – 1.16 (.0429 – .0457)	—	MD722983
Spacer – W4A32, W4A33 (For adjustment of center differential front side gear and play)	0.53 – 0.60 (.0209 – .0236)	41	MD727941
	0.69 – 0.76 (.0272 – .0299)	34	MD727934
	0.85 – 0.92 (.0335 – .0362)	32	MD727932
	1.01 -1.08 (.0398 – .0425)	30	MD727930
	1.17-1.24 (.0461 – .0498)	28	MD727928
Spacer – W4A32, W4A33 (For adjustment of center differential rear side gear and play)	0.59 – 0.66 (.0232 – .0260)	73	MD724973
	0.75 – 0.82 (.0295 – .0323)	46	MD724946
	0.93 – 1.00 (.0366 – .0394)	81	MD720681
	1.09 – 1.16 (.0429 – .0457)	43	MD724943
	1.25-1.32 (.0492 – .0520)	72	MD724972
Spacer – W4A32, W4A33 (For adjustment of drive bevel gear mount)	1.34 (.0528)	34	MD723600
	1.37 (.0539)	37	MD723601
	1.40 (.0551)	40	MD723602
	1.43 (.0563)	43	MD723603
	1.46 (.0575)	46	MD723604
	1.49 (.0587)	49	MD723605
	1.52 (.0598)	52	MD723606
	1.55 (.0610)	55	MD723607
	1.58 (.0622)	58	MD723608
	1.61 (.0634)	61	MD723609
	1.64 (.0646)	64	MD7261 70
1.67 (.0657)	67	MD7261 71	

Part name	Thickness mm (in.)	Identification symbol	Part No.
Spacer – W4A32, W4A33 (For adjustment of drive bevel gear train preload)	1.28 (.0504)	B28	MD7261 67
	1.31 (.0516)	B31	MD7261 68
	1.34 (.0528)	B34	MD7261 69
	1.37 (.0539)	B37	MD724326
	1.40 (.0551)	B40	MD724327
	1.43 (.0563)	B43	MD724328
	1.46 (.0575)	B46	MD724329
	1.49 (.0587)	B49	MD724330
	1.52 (.0598)	B52	MD724331
	1.55 (.0610)	B55	MD724332
	1.58 (.0622)	B58	MD724333
	1.61 (.0634)	B61	MD724334
	1.64 (.0646)	B64	MD724335
	1.67 (.0657)	B67	MD724336
	1.70 (.0669)	B70	MD724337
	1.73 (.0681)	B73	MD724338
	1.76 (.0693)	B76	MD724339
1.79 (.0705)	B79	MD724340	
1.82 (.0717)	B82	MD724341	
1.85 (.0728)	B85	MD724342	
Spacer – W4A32, W4A33 (For adjustment of driven bevel gear train preload)	1.19 (.0469)	19	MD7261 72
	1.22 (.0480)	22	MD722081
	1.25 (.0492)	25	MD722082
	1.28 (.0504)	28	MD722083
	1.31 (.0516)	31	MD722084
	1.34 (.0528)	34	MD722085
	1.37 (.0539)	37	MD722086
	1.40 (.0551)	40	MD722087
	1.43 (.0563)	43	MD722088
	1.46 (.0575)	46	MD722089
	1.49 (.0587)	49	MD722090
	1.52 (.0598)	52	MD722091
	1.55 (.0610)	55	MD722092
	1.58 (.0622)	58	MD722093
	1.61 (.0634)	61	MD722094
	1.64 (.0646)	64	MD722095
	1.67 (.0657)	67	MD722096
1.70 (.0669)	70	MD722097	
1.73 (.0681)	73	MD722098	
1.76 (.0693)	76	MD722099	
1.79 (.0705)	79	MD7221 00	
1.82 (.0717)	82	MD7221 01	
1.85 (.0728)	85	MD7221 02	
1.88 (.0740)	88	MD722 103	
1.91 (.0752)	91	MD7221 04	
1.94 (.0764)	94	MD7221 05	

Part name	Thickness mm (in.)	Identification symbol	Part No.
Spacer – W4A32, W4A33 (For adjustment of driven bevel gear mount)	0.13 (.0051)	13	MD720353
	0.16 (.0063)	16	MD720354
	0.19 (.0075)	19	MD720355
	0.22 (.0087)	22	MD720356
	0.25 (.0098)	25	MD720357
	0.28 (.0110)	28	MD720358
	0.31 (.0122)	31	MD720359
	0.34 (.0134)	34	MD720360
	0.37 (.0146)	37	MD720361
	0.40 (.0517)	40	MD720362
	0.43 (.0169)	43	MD720363
	0.46 (.0181)	46	MD720364
	0.49 (.0193)	49	MD720365
	0.52 (.0205)	52	MD720366
	Spacer – W4A32, W4A33 (For adjustment of front output bearing preload)	1.16 (.0457)	16
1.19 (.0469)		19	MD736751
1.22 (.0480)		22	MD736931
1.25 (.0492)		25	MD726166
1.28 (.0504)		28	MD718517
1.31 (.0516)		31	MD71 5818
1.34 (.0528)		34	MD718519
1.37 (.0539)		37	MD71 8520
1.40 (.0551)		40	MD718521
1.43 (.0563)		43	MD71 8522
1.46 (.0575)		46	MD7 18523
1.49 (.0587)		49	MD7 18524
1.52 (.0598)		52	MD71 8525
1.55 (.0610)		55	MD71 5826
1.58 (.0622)		58	MD71 8527
1.61 (.0634)		61	MD7 18528
1.64 (.0646)		64	MD7 18529
1.67 (.0657)	67	MD7 18530	
1.70 (.0669)	70	MD71 8531	
1.73 (.0681)	73	MD72 1959	
1.76 (.0693)	76	MD721960	

SEALANTS AND ADHESIVES

<W4A32, W4A33>

Items	Specified sealants and adhesives
Transfer extension housing-Transfer adapter	MITSUBISHI Genuine Part No. MD997740 or equivalent
Front bearing retainer bolts Center differential flange bolts	3M Stud Locking Part No. 4170 or equivalent
Air breather	3M ATD Part No. 8001 or equivalent

TORQUE SPECIFICATIONS**TRANSAXLE**



	Nm	ft.lbs.
Air exhaust plug	33	24
Differential cover bolt	11	8
Differential drive gear bolt	135	98
Differential front bearing cap bolt	70	51
Differential rear bearing retainer bolt	35	26
End clutch cover bolt	11	8
Idler gear cover bolt	11	8
Idler shaft lock bolt	38	28
Park/neutral position switch (PNP switch) bolt	11	8
Kickdown servo lock nut	29	21
Manual control lever nut	19	14
Manual control shaft set screw	9	7
Oil drain bolt	33	24
Oil filter bolt	6	5
Oil lever gauge guide bolt	24	18
Oil pan bolt	11	8
Oil pressure check plug	5	4
Oil pump assembly mounting bolt	21	16
Oil pump bolt	11	8
Output bearing retainer bolt	24	18
Output flange bearing retainer bolt	20	15
Parking rod support bolt	24	18
Pulse generator bolt	11	8
Roll stopper bracket bolt	49	35
Shift control cable bracket bolt	24	18
Speedometer gear locking plate bolt	5	4
Transaxle mount bracket bolt	70	51
Valve body assembly mounting bolt	11	8
Valve body bolt	5	4
Center bearing retainer stopper bolt – W4A32, W4A33	5	4
Center differential drive gear bolt – W4A32, W4A33	75	54
Front bearing retainer bolt – W4A32, W4A33	49	35





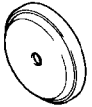
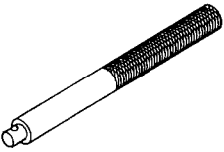
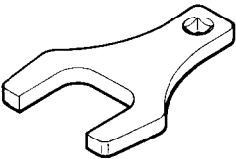
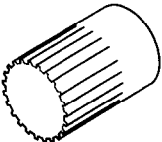
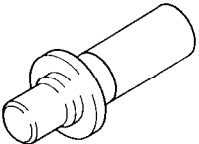
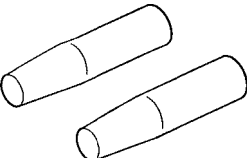
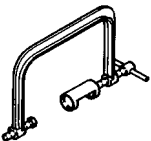
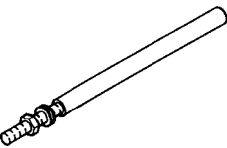

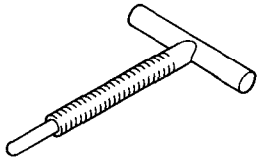
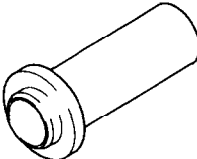
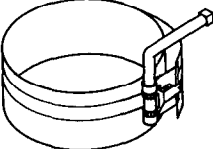
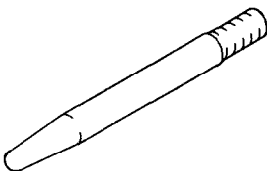
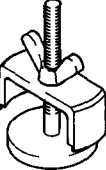
TRANSFER – W4A32, W4A33

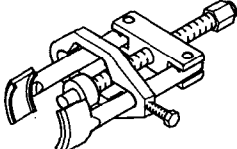
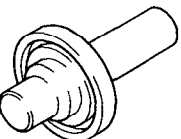
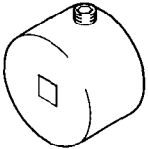

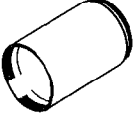
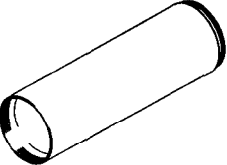
	Nm	ft.lbs.
Cover mounting bolt	5	4
Driven bevel gear lock nut	150	108
Extension housing mounting bolt	19	14
Oil drain plug	33	24
Oil filler plug	33	24
Transfer case adapter mounting bolt	39	28
Transfer cover mounting bolt	39	28

SPECIAL TOOLS

Tool	Number and tool name	Replaced by OTC tool number	Application
	MB990934 Installer adapter	MB990934-01	Installation of bearing out race
	MB990936 Installer adapter	MB990936-01	
	MB990938 Installer bar	MB990938-01	
	MB991013 Special spanner	MIT307098	Removal and installation of transfer driven bevel gear lock nut <4WD>
	MB991144 Side gear holding tool	MB991144	Measurement of transfer drive and driven bevel gears drive torque <4WD>
	MD998200 Oil seal installer	MD998200-01	Installation of rear output shaft and transfer case oil seal <4WD>
	MD998266 Guide pin	MD998266-01	Alignment of intermediate plate and valve bodies
	MD998303 Valve spring compressor	MD998341-01	Installation and removal of kickdown servo
	MD998316 Dial gauge support	MIT209038	Measurement of input shaft end play

Tool	Number and tool name	Replaced by OTC tool number	Application
	MD998333 Removers	MD998333-01	Removal and installation of oil pump assembly, center differential
	MD998334 Oil pump oil seal installer	MD998334-01	Installation of oil pump oil seal
	MD998335 Oil pump band	MD998335-01	Alignment of oil pump housing and reaction shaft support
	MD998336 Guide pin	MD998336-01	Alignment of oil pump housing and reaction shaft support
	MD998337 Spring compressor	MD998907-01	Disassembly of front clutch and rear clutch
	MD998338 Spring compressor	MD998338	Disassembly and reassembly of rear clutch
	MD998348 Bearing puller	MD998348-01	Removal of bearing
	MD998800 Oil seal installer	MD998325-01	Installation of drive shaft oil seal
	MD998806 Wrench adapter	MD998806	Measurement of transfer driven bevel gear drive torque <4WD>

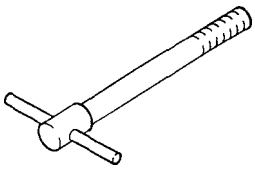
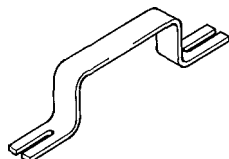
Tool	Number and tool name	Replaced by OTC tool number	Application
	MD998812 Installer cap	General service tool	Use with installer and adapter
	MD998813 Installer-100	General service tool	Use with installer cap and adapter
	MD998814 Installer-200	MIT304180	Use with installer cap and adapter
	MD998819 Installer adapter (40)	General service tool	Installation of each bearing
	MD998822 Installer adapter (46)	MD998822-01	
	MD998825 Installer adapter (52)	General service tool	
	MD998827 Installer adapter (56)	General service tool	
	MD998829 Installer adapter (60)	MD998829-01'	
	MD998830 Installer adapter (66)	General service tool	

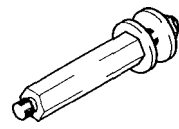
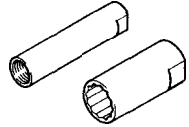
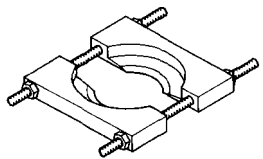
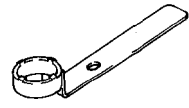
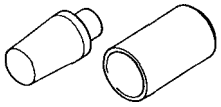
Tool	Number and tool name	Replaced by OTC tool number	Application
	MD998904 Bolt	MD998904	Pull-out idler shaft
	MD998905 Handle	MD998905-01	Removal and installation of center support
	MD998907 Spring compressor	MD998907-01	Disassembly and reassembly of front clutch and rear clutch
	MD998915 Wrench adapter	MD998916-01 MD998916-1-01	Adjustment of kickdown servo
	MD998916 Socket wrench	MD998916-2-01 MD998916-3-01	
	MD998917 Bearing remover	MD998917	Disassembly and reassembly of transfer driven gear, bearing
	MD998918 Kickdown servo wrench	MD998918	Adjustment of kickdown servo
	MD998919 Snap ring installer	MD998919	Reassembly of end clutch

**TRANSAXLE – FWD
COMPONENTS**

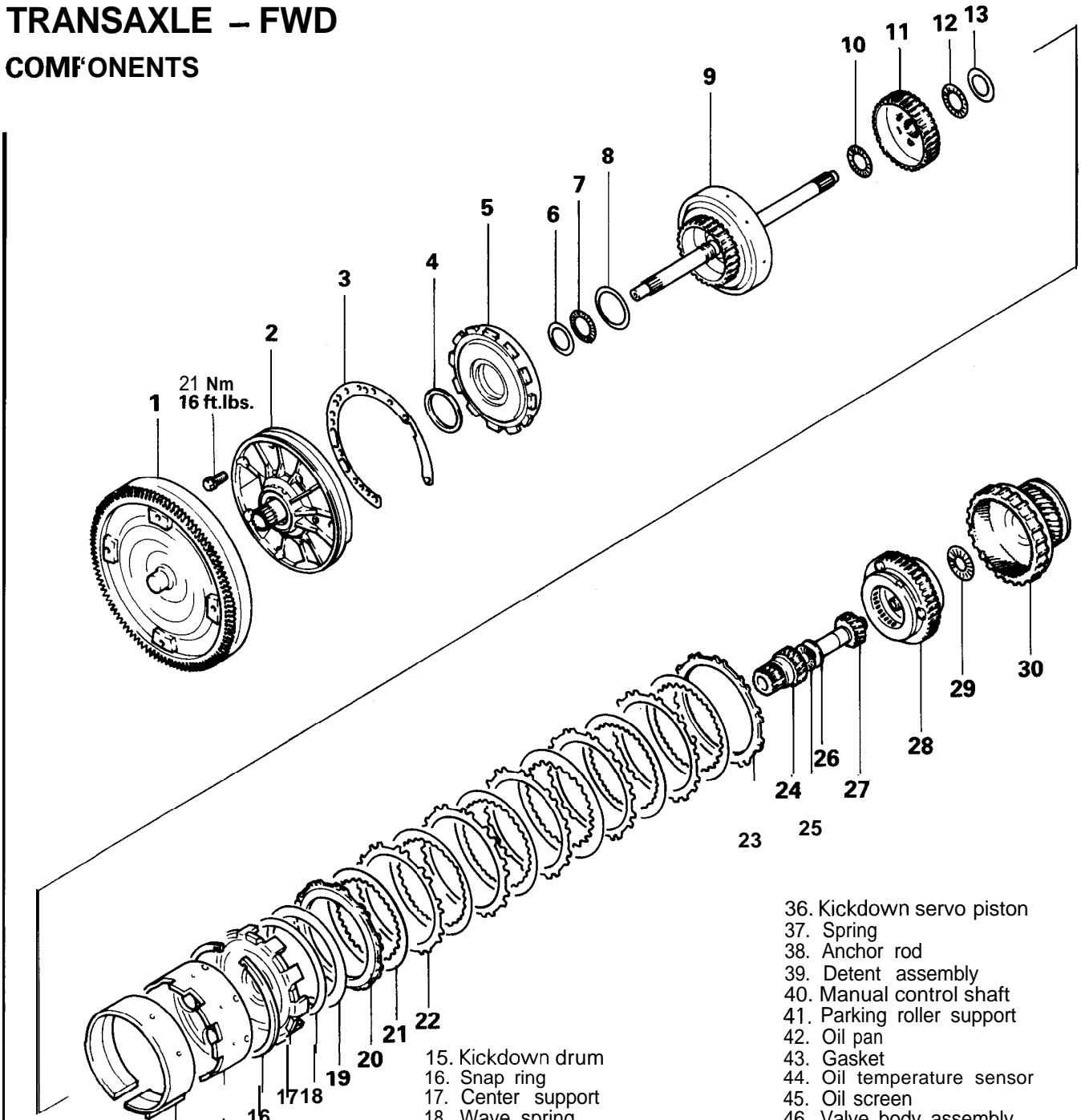

- 1. Torque converter
- 2. Oil pump assembly
- 3. Gasket
- 4. Thrust washer #1
- 5. Front clutch assembly
- 6. Thrust race #3
- 7. Thrust bearing #4
- 8. Thrust washer #2
- 9. Rear clutch assembly
- 10. Thrust bearing #5
- 11. Rear clutch hub
- 12. Thrust race #6
- 13. Thrust bearing #7
- 14. Kickdown band

- 15. Kickdown drum
- 16. Snap ring
- 17. Center support
- 18. Wave spring
- 19. Return spring
- 20. Pressure plate
- 21. Brake disc
- 22. Brake plate
- 23. Reaction plate
- 24. Reverse sun gear
- 25. Thrust bearing #8
- 26. Thrust race #9
- 27. Forward sun gear
- 28. Planetary carrier assembly
- 29. Thrust bearing #10
- 30. Output flange
- 31. Oil level gauge
- 32. Oil filler tube
- 33. Snap ring
- 34. Kickdown servo switch
- 35. Snap ring

- 36. Kickdown servo piston
- 37. Spring
- 38. Anchor rod
- 39. Detent assembly
- 40. Manual control shaft
- 41. Parking roller support
- 42. Oil pan
- 43. Gasket
- 44. Oil temperature sensor
- 45. Oil screen
- 46. Valve body assembly
- 47. Manual control lever
- 48. Park/neutral position switch (PNP switch)
- 49. End clutch shaft
- 50. Bearing retainer
- 51. Thrust bearing #11
- 52. End clutch hub
- 53. Thrust washer
- 54. End clutch assembly
- 55. O-ring
- 56. End clutch cover
- 57. Pulse generator
- 58. Lock bolt
- 59. Idler shaft
- 60. Idler gear
- 61. Spacer
- 62. Gasket

TSB Revision

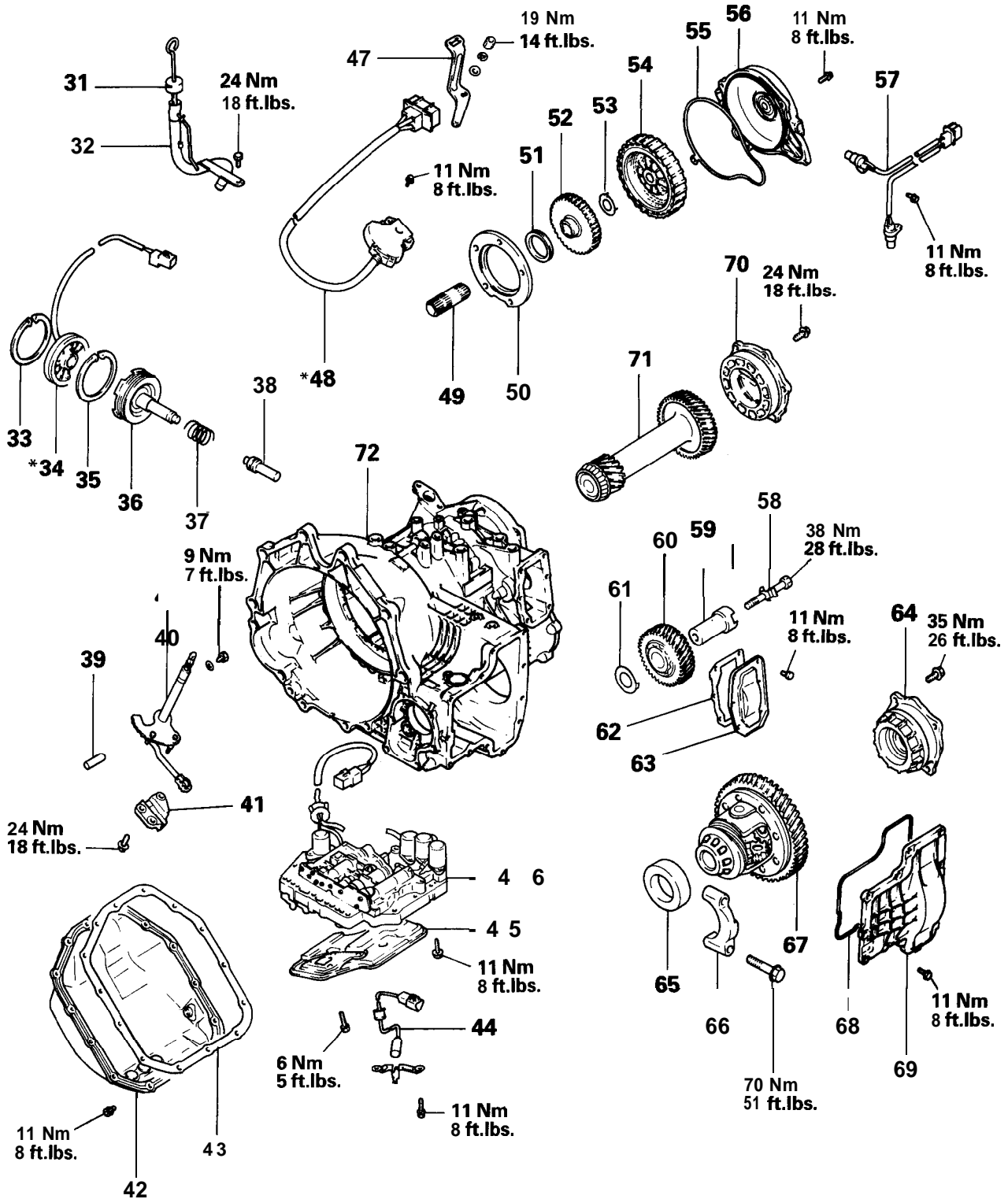

- 63. Idler gear cover
- 64. Differential bearing retainer
- 65. Outer race
- 66. Differential front bearing cap
- 67. Differential assembly
- 68. Gasket
- 69. Differential cover
- 70. Outer bearing retainer
- 71. Transfer shaft
- 72. Transaxle case

NOTE:
On 1993 and subsequent models, *-marked parts have the connector directly attached, not via a harness.

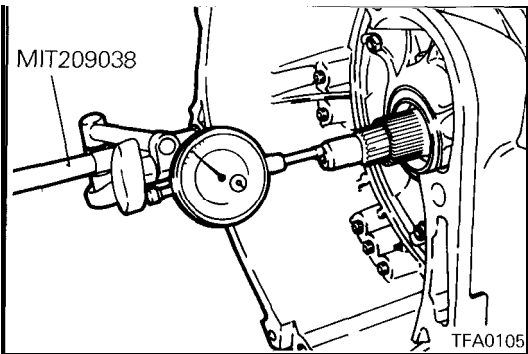

DISASSEMBLY

1. Clean away any sand, mud, etc. adhered around the transaxle.
2. Place the transaxle assembly on the workbench with the oil pan down.
3. Remove the torque converter.
4. Use the special tool to mount the dial gauge on the transmission case and measure the end play of the input shaft.

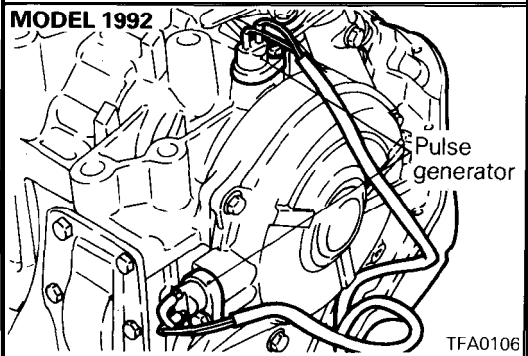

5. Remove the pulse generator "A" and "B".

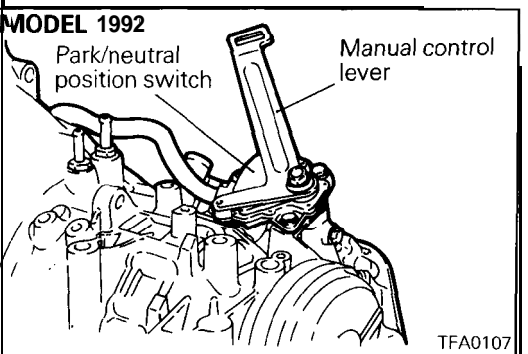
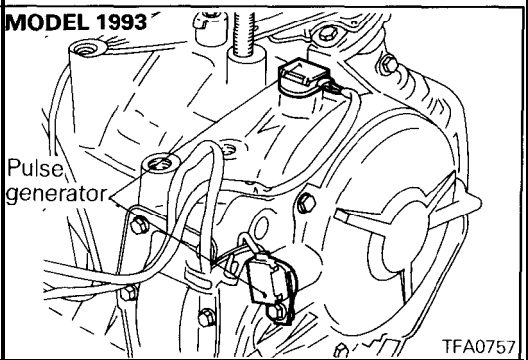

6. Remove manual control lever then remove park/neutral position switch (PNP switch).

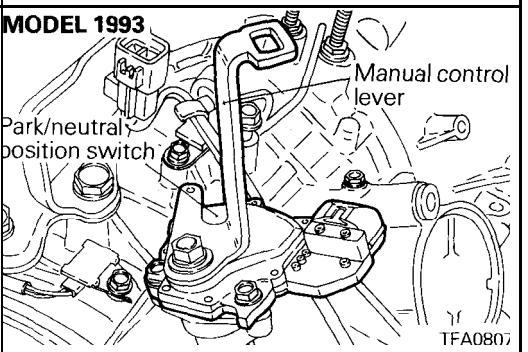

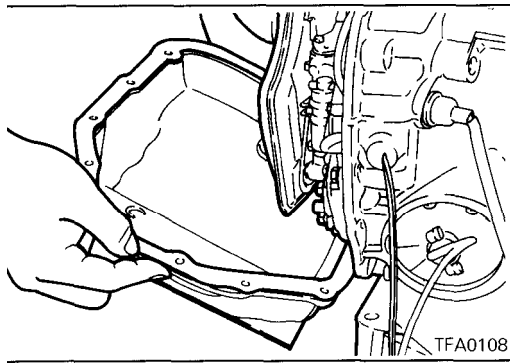

7. Remove the oil pan, magnets and gasket.

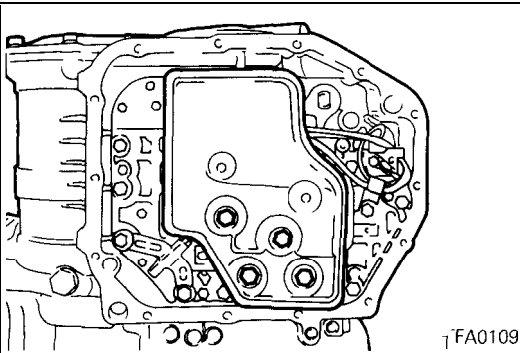

8. Remove the oil filter from the valve body.

MODEL 1992

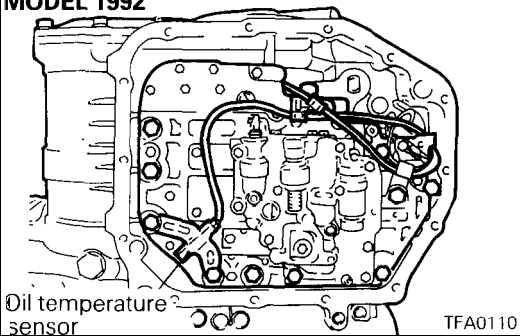

9. Remove the 10 valve body mounting bolts.

10. Remove the oil temperature sensor holder and remove the oil temperature sensor harness from the clamp.

MODEL 1993

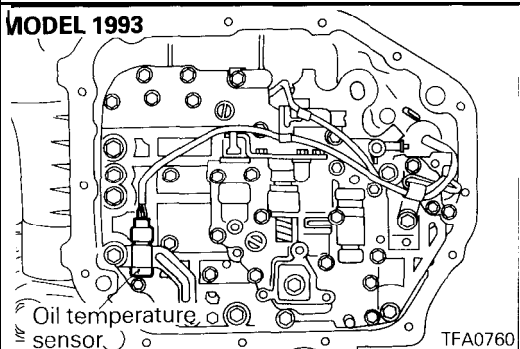

11. Press the finger of the solenoid valve harness grommet, push the grommet into the case and remove the valve body assembly.

12. Pull out the oil temperature sensor.

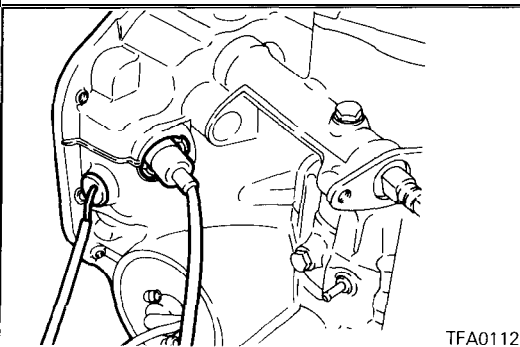

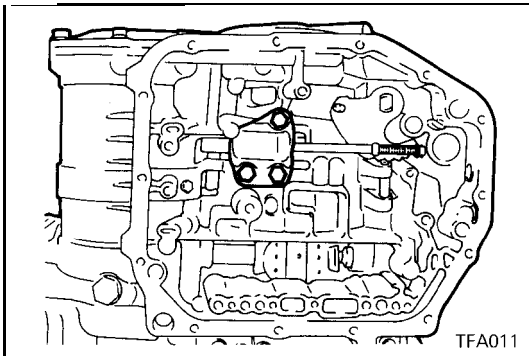

13. Remove the parking roller support.

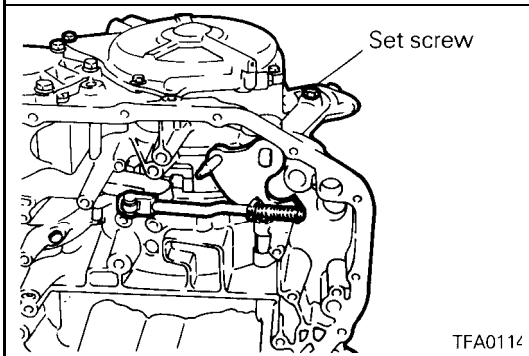

14. Remove the set screw of the manual control shaft and remove the manual control shaft assembly.

15. Remove the detent assembly.

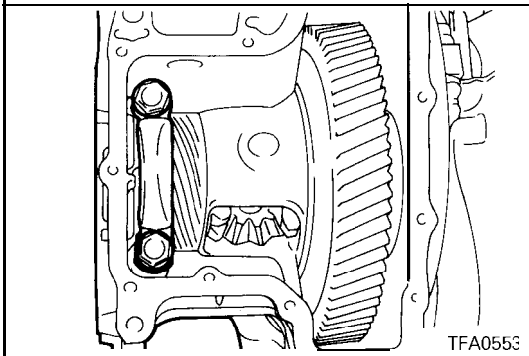

16. Remove the differential cover and gasket.

17. Remove the differential front bearing cap.

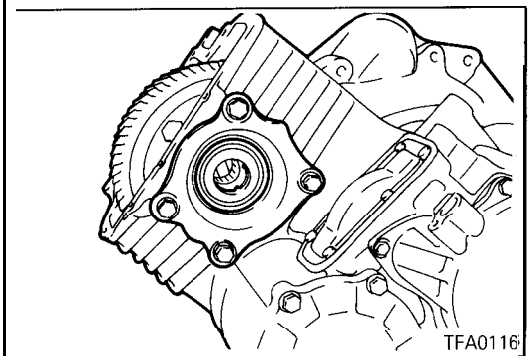

18. Remove the differential bearing retainer, spacer and outer race.

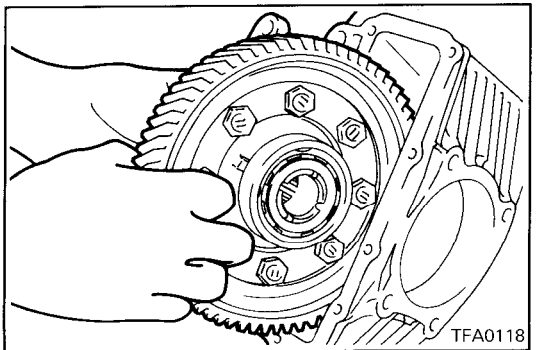

19. Remove the differential assembly.

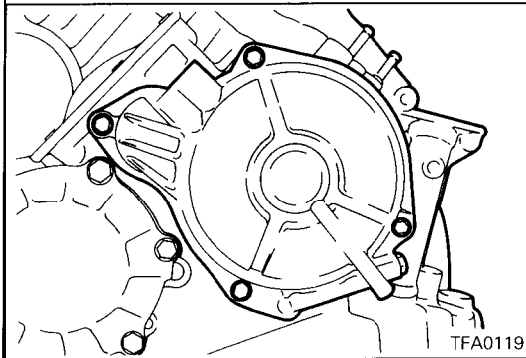

20. Take out the end clutch cover installation bolts, then remove the cover holder and end clutch cover.

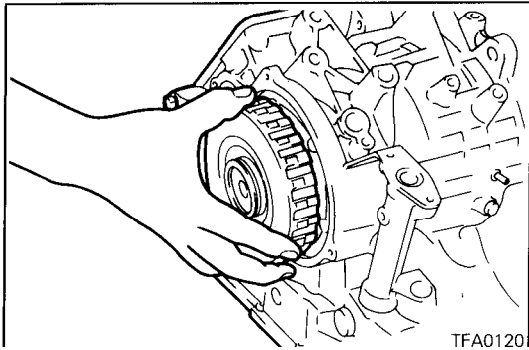

21. Remove the end clutch assembly.

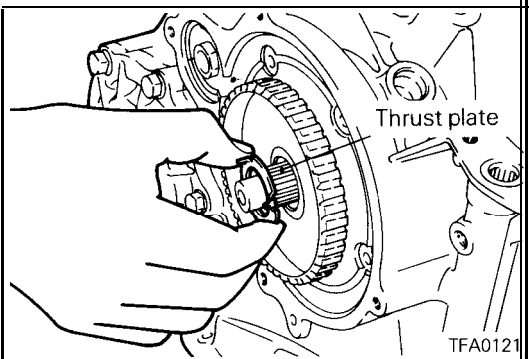

22. Remove the thrust plate.

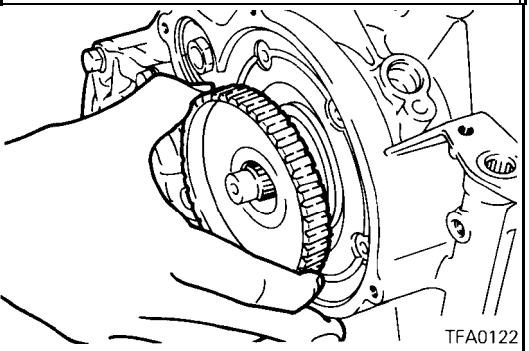

23. Remove the end clutch hub.
24. Remove the thrust bearing #11.

NOTE

It may be stuck to the end clutch hub.

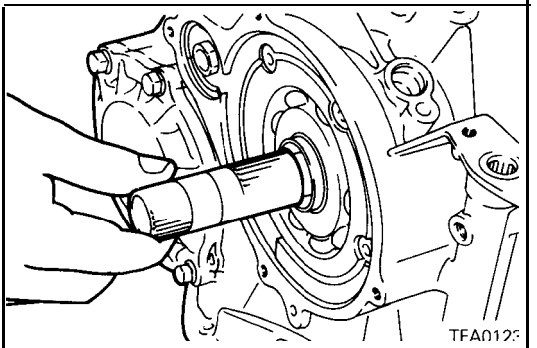

25. Pull out the end clutch shaft.

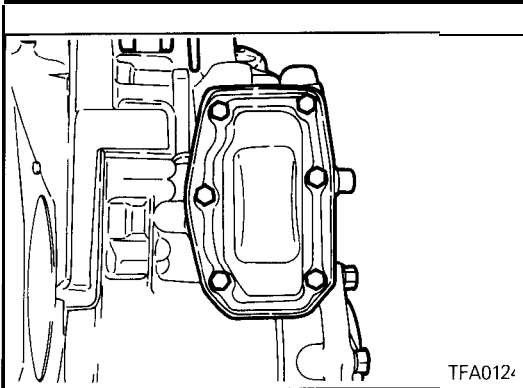

26. Remove the idler gear cover mounting bolts, then remove the idler gear cover and gasket.

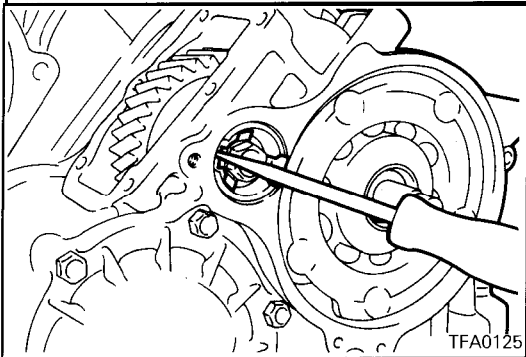

27. Disengage the bolt stopper and remove the bolt.

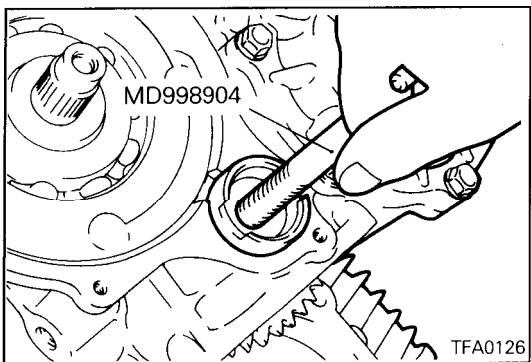

28. Using the special tool, pull out the idler shaft and then remove the idler gear and bearing inner race.

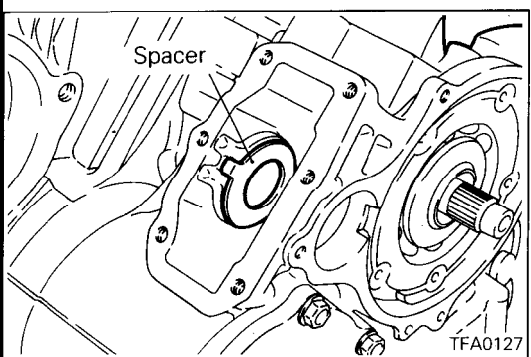

29. Remove the spacer.

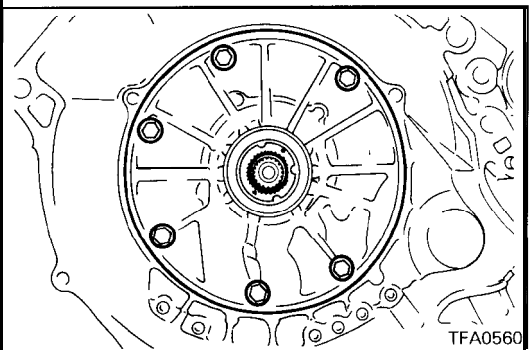

30. Remove oil pump installation bolts.

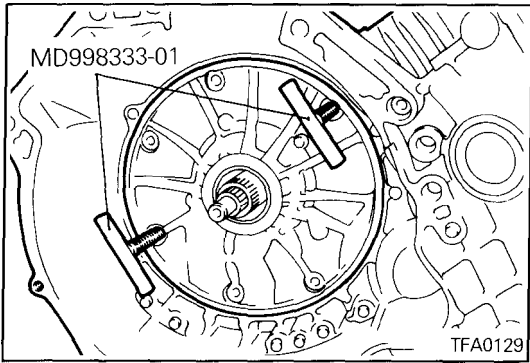

31. Use the special tool and remove the oil pump.

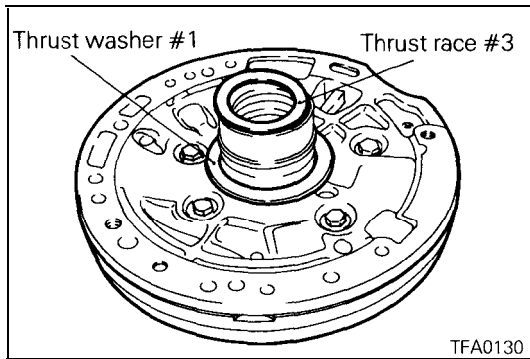

32. Remove thrust washer #1 and thrust race #3.

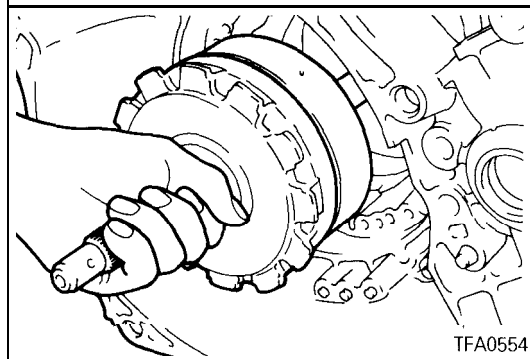

33. Hold the input shaft and remove the front clutch assembly and rear clutch assembly together.

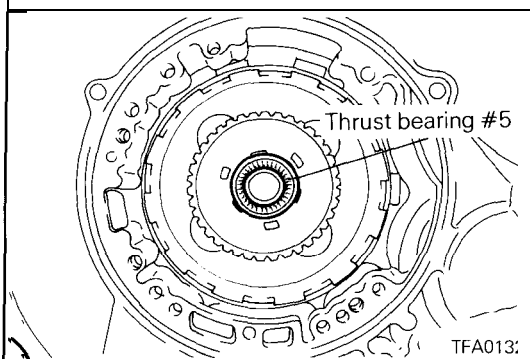

34. Remove the thrust bearing #5.

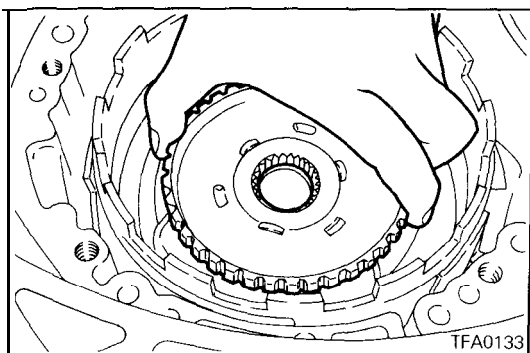

35. Remove the clutch hub.

NOTE

The thrust race may be stuck to the clutch hub.

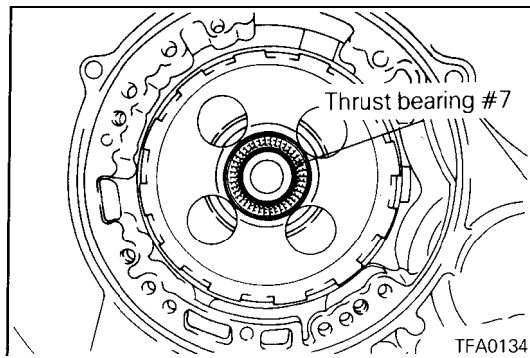

36. Remove the thrust bearing #7.

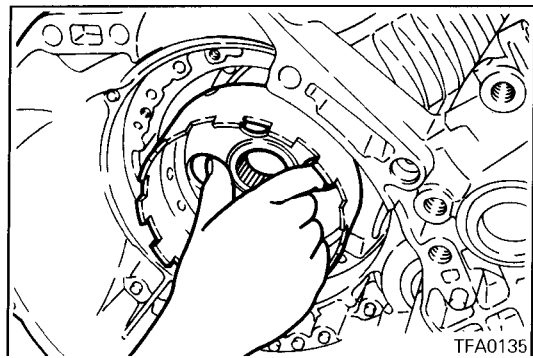

37. Remove the kickdown drum.

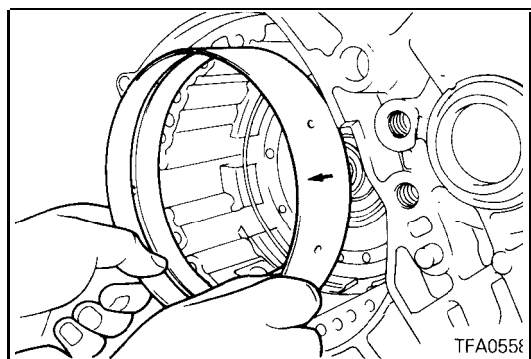

38. Remove the kickdown band.

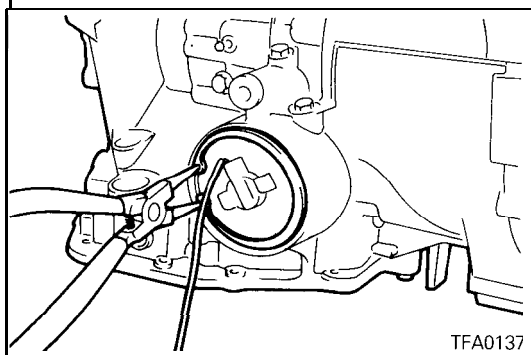

39. Remove the kickdown servo cover snap ring. Then remove the kickdown servo switch.

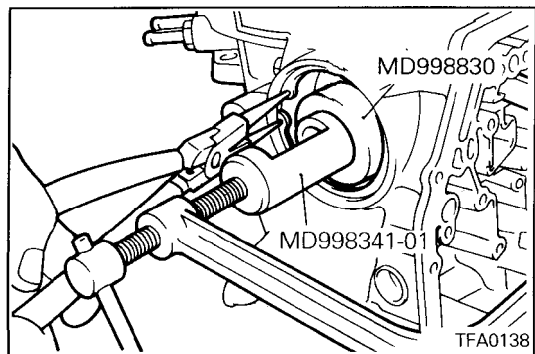

40. Using the special tool, push in the kickdown servo and remove the snap ring.

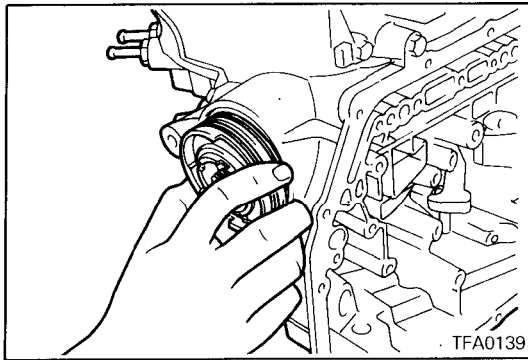

41. Remove the kickdown servo piston.

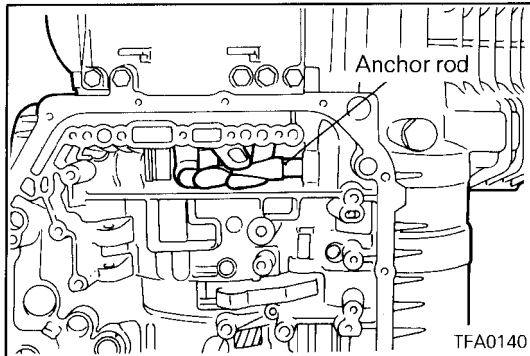

42. Remove the anchor rod.

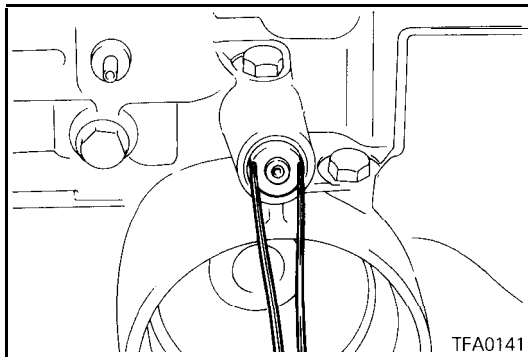

43. Remove the plug, then remove the air exhaust plug.

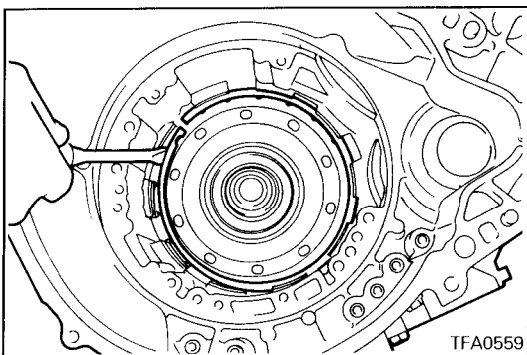

44. Remove the snap ring.

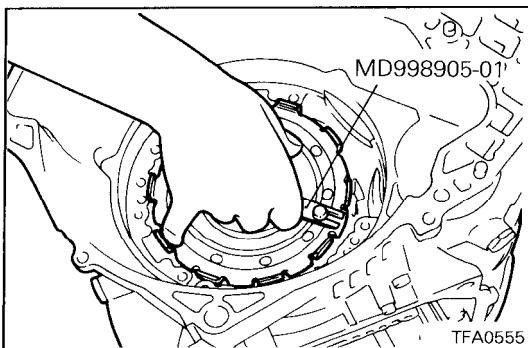

45. Using the special tool, remove the center support.

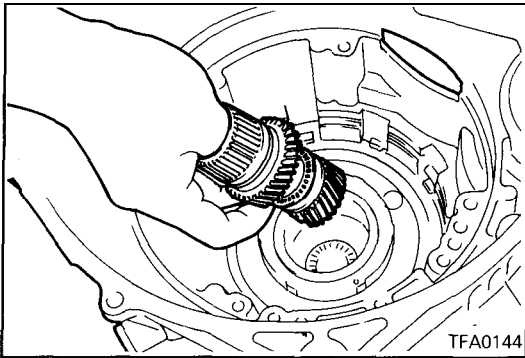

46. Remove reverse sun gear and forward sun gear together.

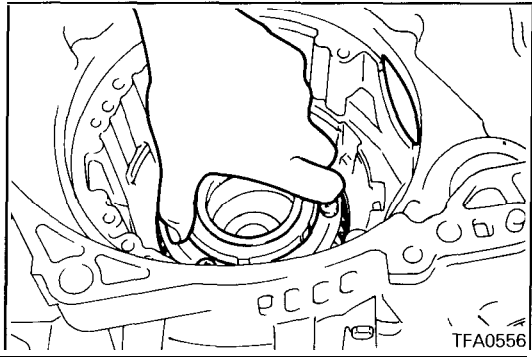

47. Remove planet carrier assembly.

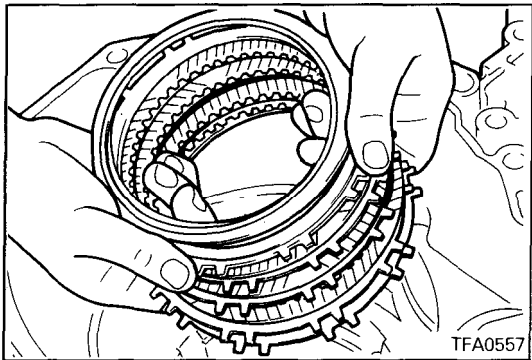

48. Remove the wave spring, return spring, reaction plate, brake discs, and brake plates.

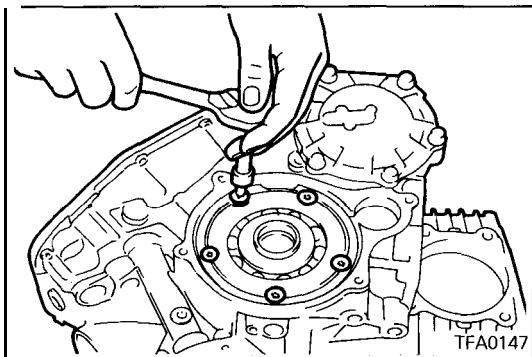

49. Remove the screws and the rear bearing retainer.

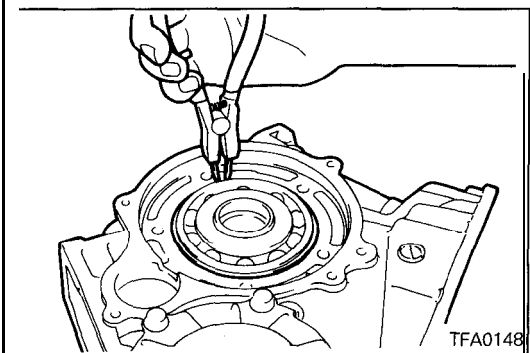

50. Remove the snap ring and then remove the output flange assembly.

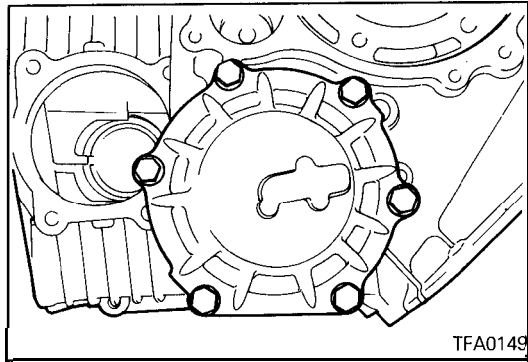

51. Remove the output bearing retainer mounting bolts and then remove the output bearing retainer and outer race.

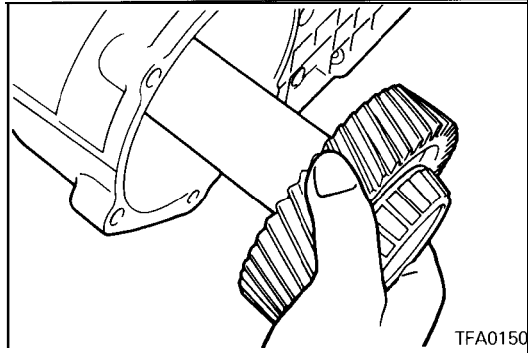

52. Remove the transfer shaft.

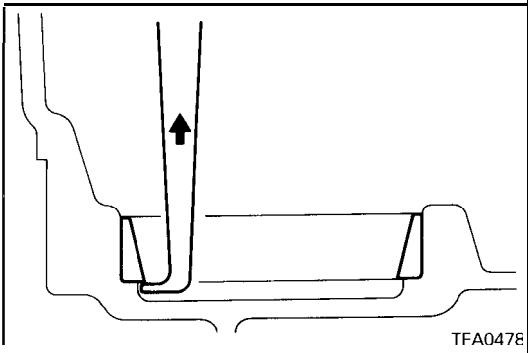

53. Use a sliding hammer, etc., to remove the outer race.
54. Remove all oil seals.

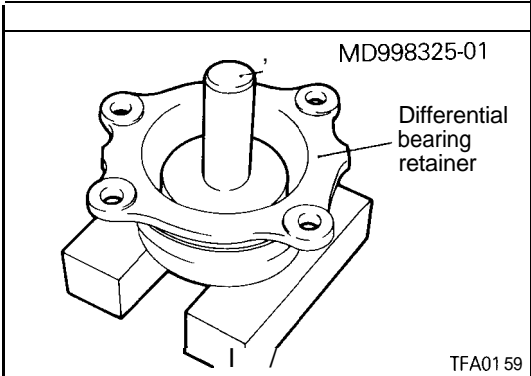

REASSEMBLY

1. Using the special tool, install the oil seals to the differential bearing retainer and transaxle case.

	Special tool
Oil seal for differential bearing retainer	MD998325-01
Oil seal for transaxle case	MD998325-01 (MD998803*)

*: Vehicles with 4-wheel steering oil pump

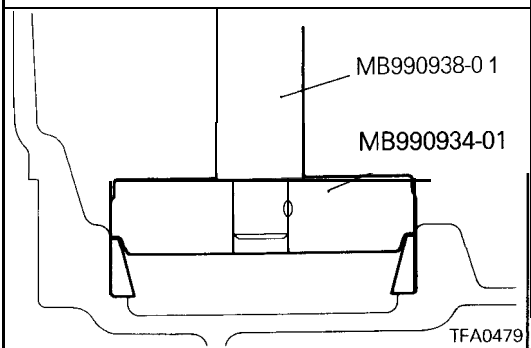

2. Use the special tool to press fit the outer race into the transaxle case.

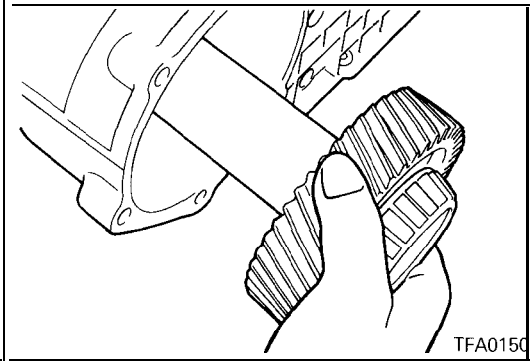

3. Install the transfer shaft

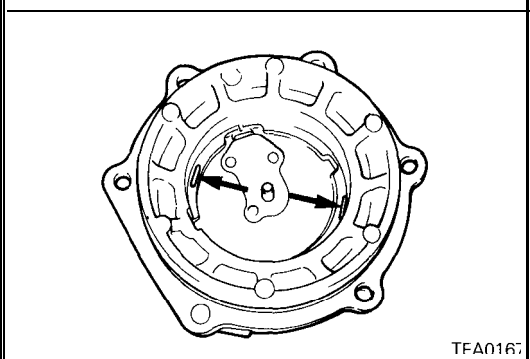

4. Place solder with a length of approximately 10 mm (.39 in.) and diameter of 1.6 mm (.06 in.) on the output bearing retainer at the position shown in the diagram and install the outer race.

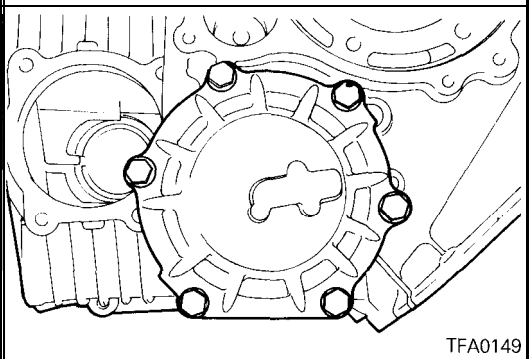

5. Install the output bearing retainer and tighten the bolts to the specified torque.

**Output bearing retainer mounting bolts:
24 Nm (18 ft.lbs.)**

6. Loosen the bolts and remove the output bearing retainer.

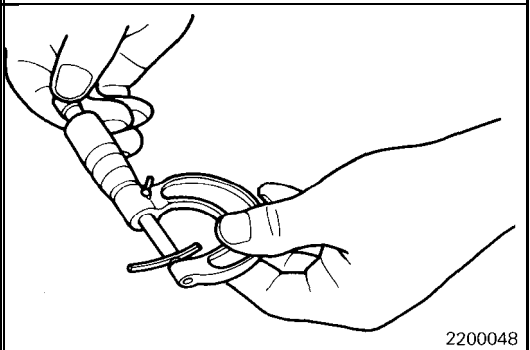

7. Remove the outer race from the output bearing retainer and remove the solder. If the solder is not crushed, repeat steps (4) – (6), using the solder with diameter of 3 mm (.12 in.). Measure the thickness of the crushed solder with a micrometer and select a spacer with a thickness that will provide the standard value for the preload.

Standard value: 0.075 – 0.135 mm (.003 – .0053 in.)

8. Install the spacer selected in the previous item and the outer race on the output bearing retainer.

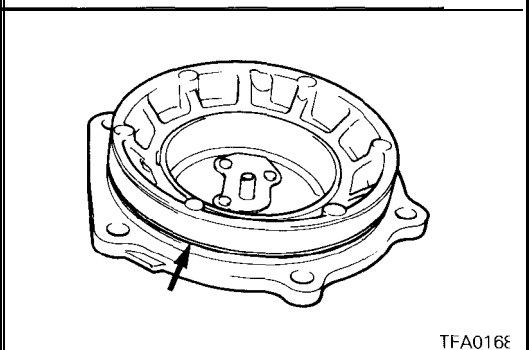

9. Install a new O-ring around the outer circumference of the outer bearing retainer.

10. Coat the O-ring with automatic transmission fluid and tighten the output bearing retainer mounting bolts to the specified torque.

**Output bearing retainer mounting bolts:
24 Nm (18 ft.lbs.)**

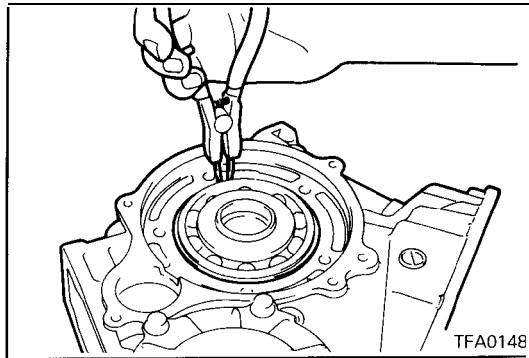

11. Insert the output flange into the case and install a snap ring around the bearing.

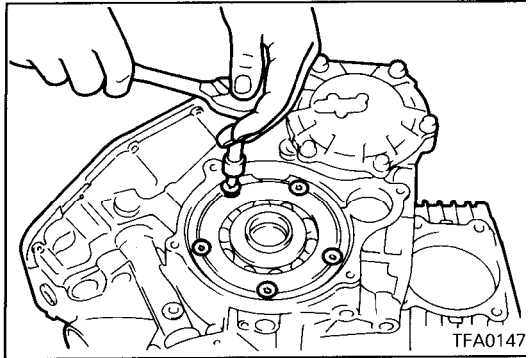

12. Install the bearing retainer using new bolts.
Bearing retainer mounting bolts: 20 Nm (15 ft.lbs.)

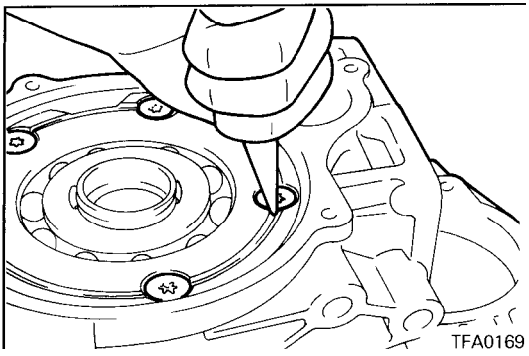

13. Caulk the heads of the bolts.

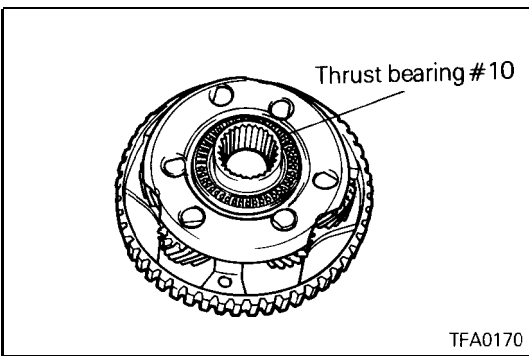

14. Apply a coating of petrolatum to thrust bearing #10 and attach to the planetary carrier.

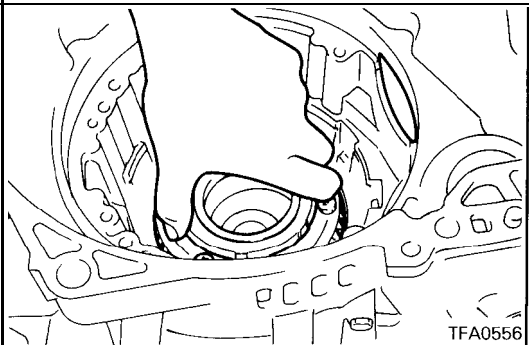

15. Assemble the planetary carrier.

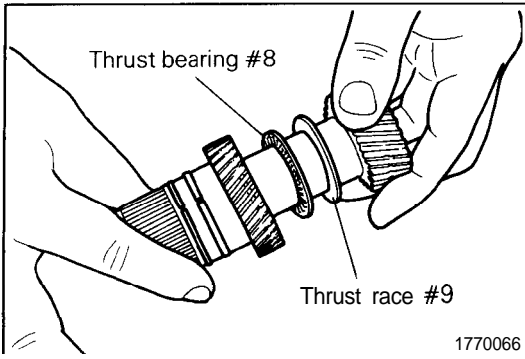

16. Assemble the forward sun gear, thrust race #9, thrust bearing #8 and reverse sun gear.

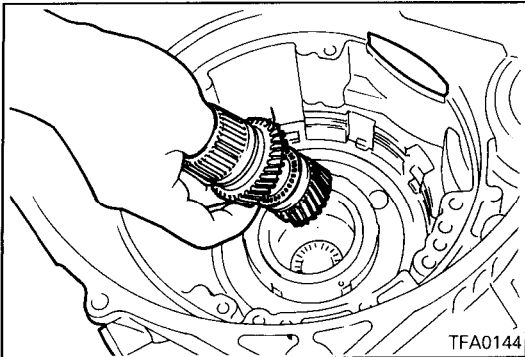

17. Install both sun gears assembled in the previous item into the planetary carrier.

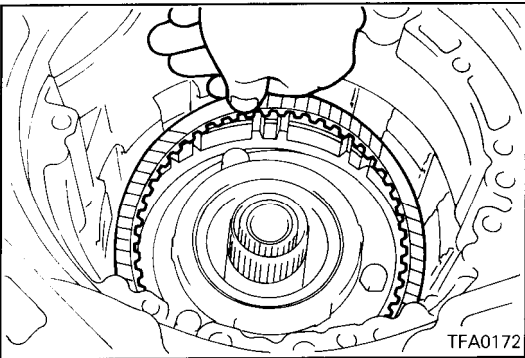

18. Assemble the reaction plate, brake disc and brake plate.

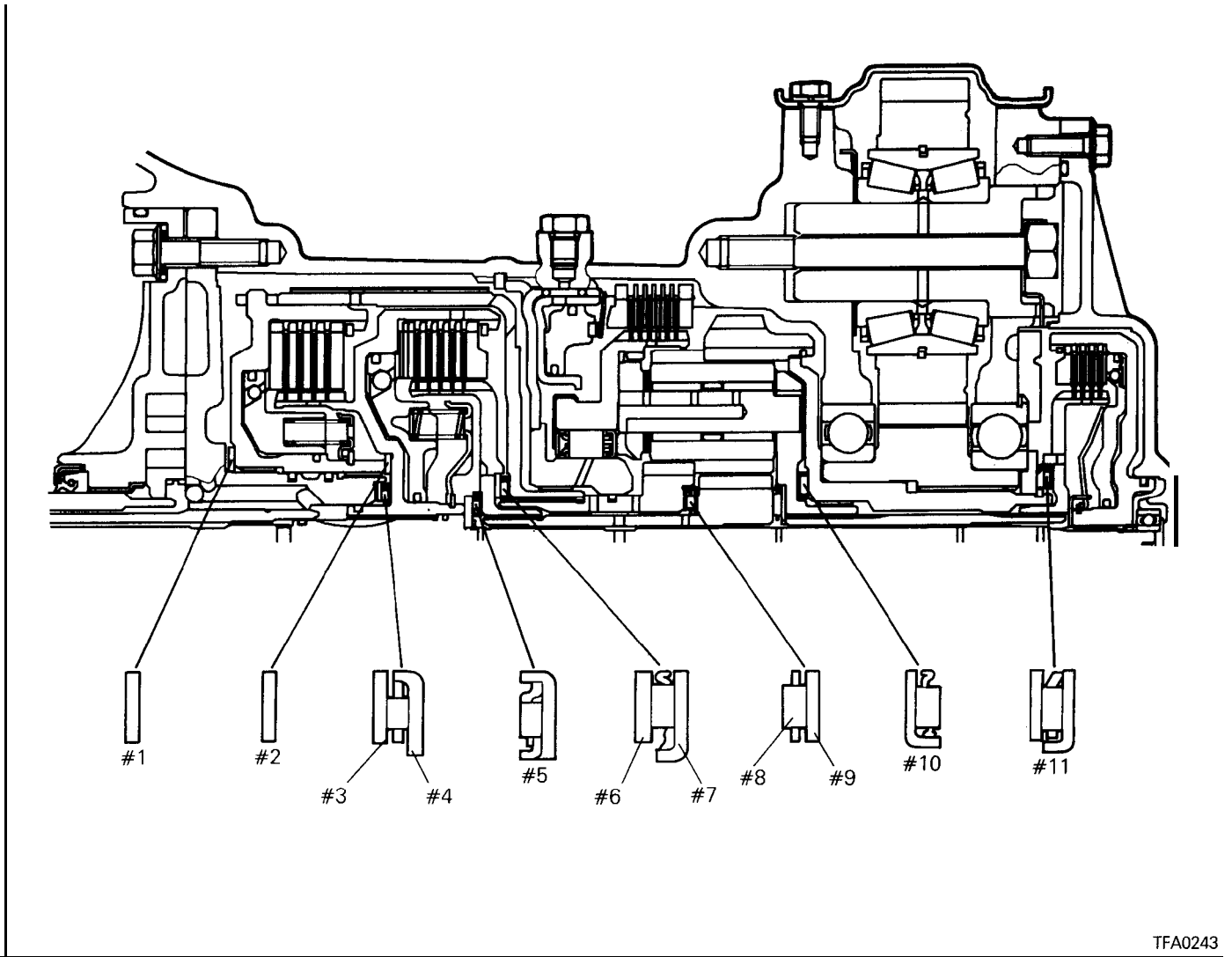

TFA0243

Identification of thrust bearings, thrust races and thrust washers

Unit: mm (in.)

D	d	t	Part No.	Sym- bol	D	d	t	Part No.	Sym- bol
70 (2.76)	55.7 (2.193)	1.4 (.055)	*1	#1	48.1 (1.894)	34.4 (1.354)	–	MD707271	#4
70 (2.76)	55.7 (2.193)	1.8 (.071)	*2		42.6 (1.677)	28 (1.10)	–	MD720753	#5
70 (2.76)	55.7 (2.193)	2.2 (.087)	*3		54 (2.13)	38.7 (1.524)	1.6 (.063)	MD704936	#6
70 (2.76)	55.7 (2.193)	2.6 (.102)	*4		52 (2.05)	36.4 (1.433)	–	MD720010	#7
66 (2.60)	54 (2.13)	1.8 (.071)	MD731212	#2	45 (1.77)	28 (1.10)	–	MD735062	#8
48.9 (1.925)	37 (1.46)	1.0 (.039)	MD997854 (incl. *1	#3	46 (1.81)	31 (1.22)	0.8 (.031)	MD735063	#9
48.9 (1.925)	37 (1.46)	1.2 (.047)	MD997847 (incl. *1		52 (2.05)	36.4 (1.433)	–	MD720010	#10
48.9 (1.925)	37 (1.46)	1.4 (.055)	MD997848 (incl. *2		58 (2.28)	44 (1.73)	–	MD724206	#11
48.9 (1.925)	37 (1.46)	1.6 (.063)	MD997849 (incl. *2						
48.9 (1.925)	37 (1.46)	1.8 (.071)	MD997850 (incl. *3						
48.9 (1.925)	37 (1.46)	2.0 (.079)	MD997851 (incl. *3						
48.9 (1.925)	37 (1.46)	2.2 (.087)	MD997852 (incl. *4						
48.9 (1.925)	37 (1.46)	2.4 (.094)	MD997853 (incl. *4						

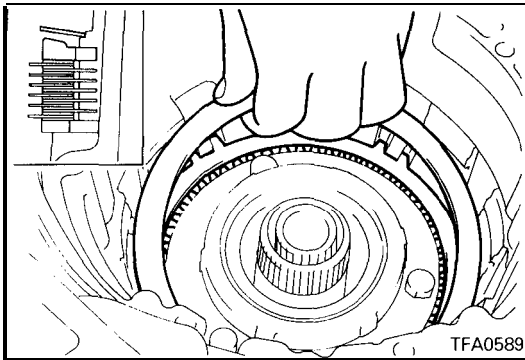

19. Assemble the pressure plate used in disassembly and install the return spring.

Caution

Position the return spring correctly when installing.

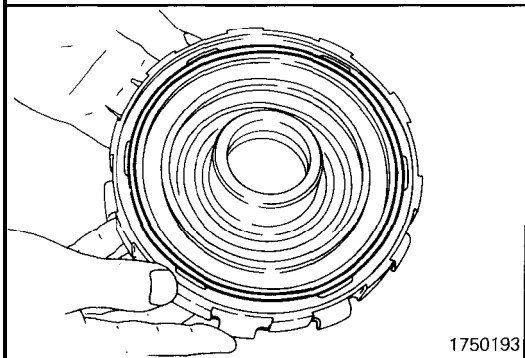

20. Apply a coating of petrolatum jelly to the wave spring and attach it to the center support.

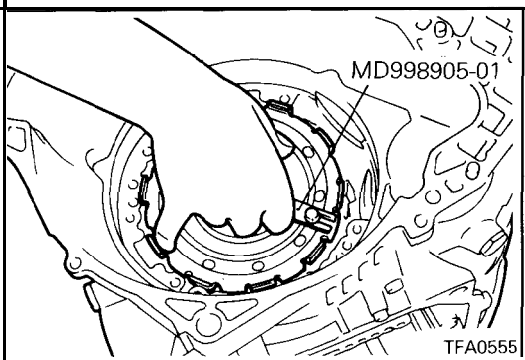

21. Mount the special tool on the center support, install 2 new O-rings and push into the transaxle case.

Caution

1. **Coat the O-rings with automatic transmission fluid and align the oil holes.**
2. **Do not move the wave spring out of position when installing.**

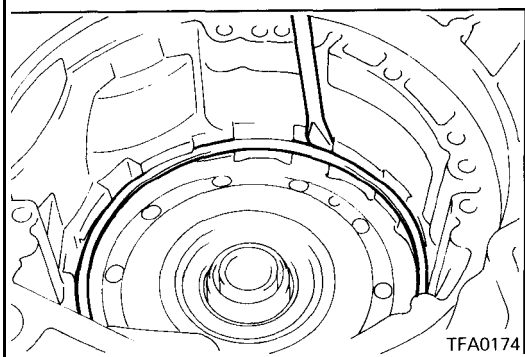

22. Install the snap ring.

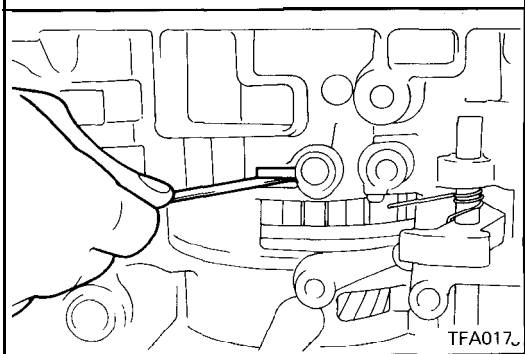

23. Use a thickness gauge and measure the end play of the low/reverse brake. Adjust to the standard value by selecting the proper pressure plate.

Standard value: 1.0 – 1.2 mm (.039 – .047 in.)

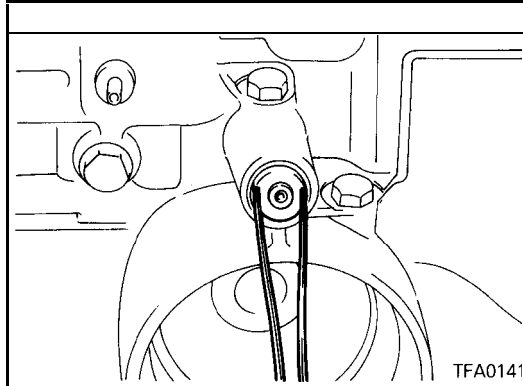

24. Install the air exhaust plug, and then install the plug.
Air exhaust plug: 33 Nm (24 ft.lbs.)

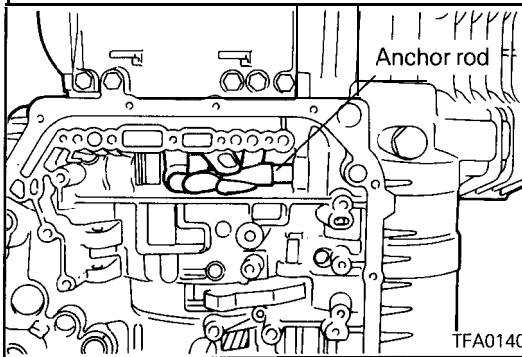

25. Install the anchor rod.

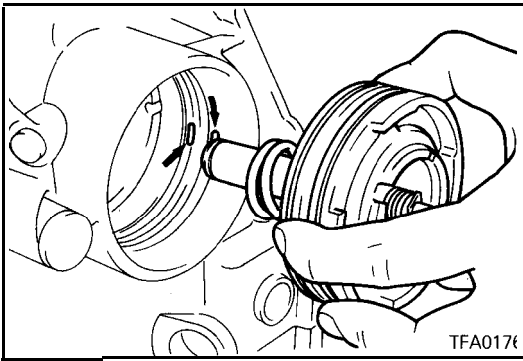

26. Install the kickdown servo spring, piston and sleeve.

Caution

The seal ring alignment hole of the **kickdown servo piston** must not overlap the oil filler port (indicated by the arrow in the diagram).

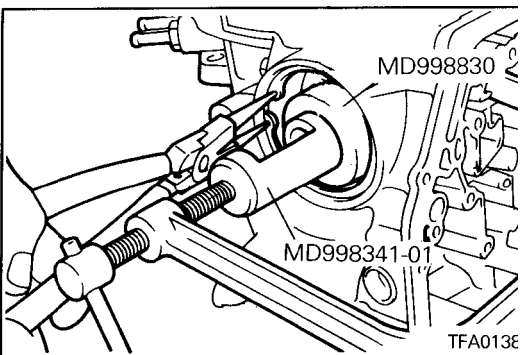

27. Use the special tool to push in the kickdown servo piston and sleeve, and then install a snap ring.

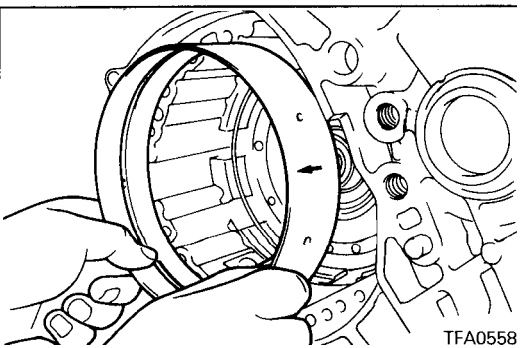

28. Install the kickdown band.

Caution

Install so the arrow mark is facing toward the front.

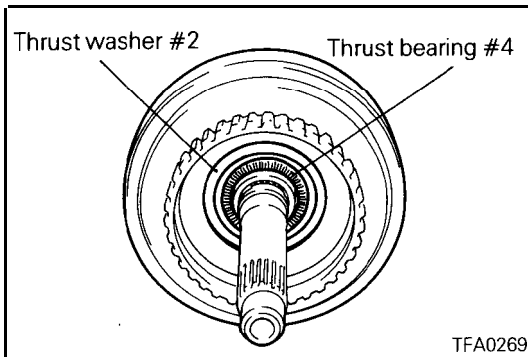

29. Install thrust bearing #4 and thrust washer #2 on the rear clutch.

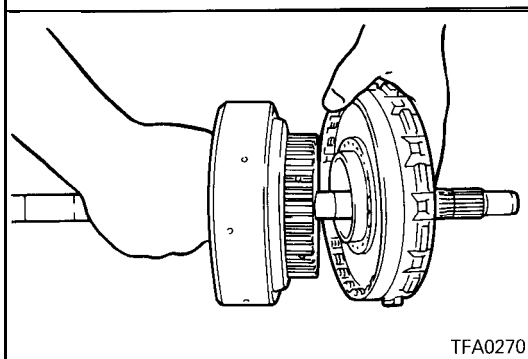

30. Combine the rear clutch assembly and the front clutch assembly.

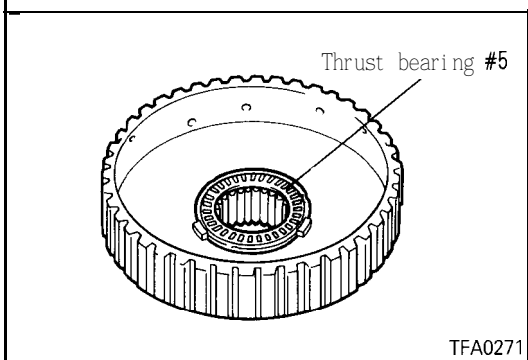

31. Install thrust bearing #5 on the rear clutch hub.

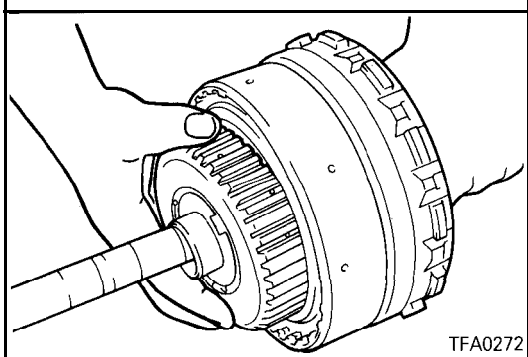

32. Install the rear clutch hub on the rear clutch.

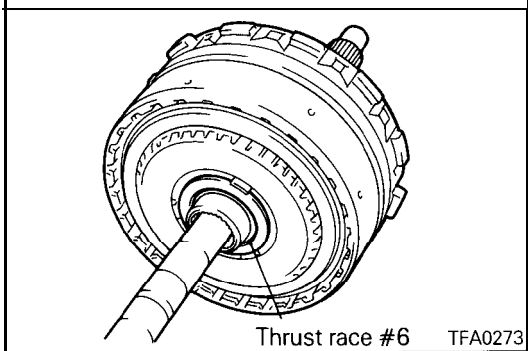

33. Install thrust race #6 on the end of the rear clutch hub.

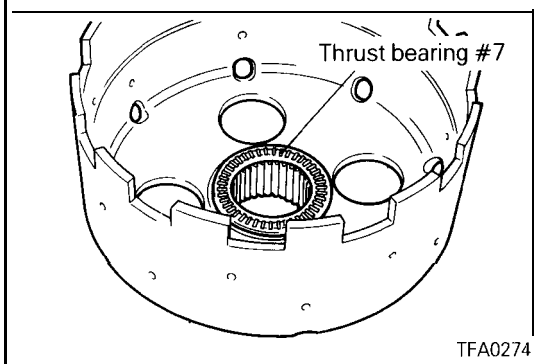

34. Install thrust bearing #7 in the kickdown drum.

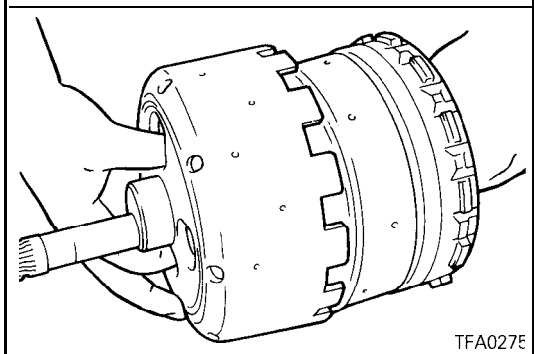

35. Install the clutch assembly in the kickdown drum

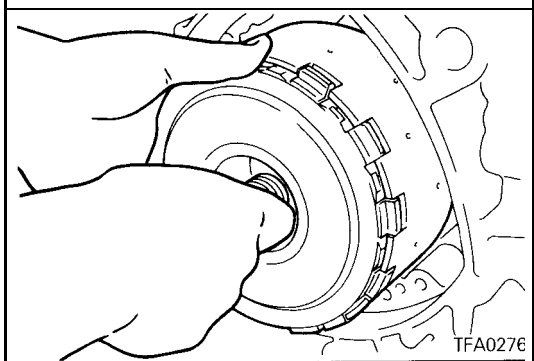

36. Install the clutch assembly and kickdown drum into the transaxle case at the same time.

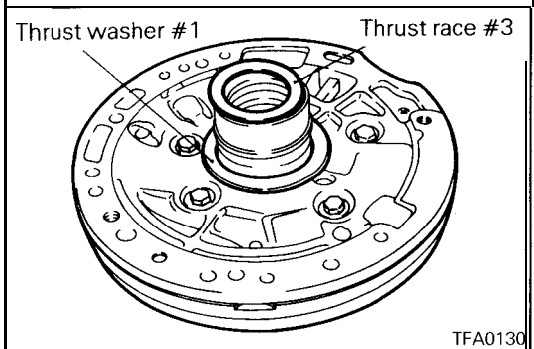

37. Adhere thrust race #3 and thrust washer #1 to the back of the oil pump with petrolatum.

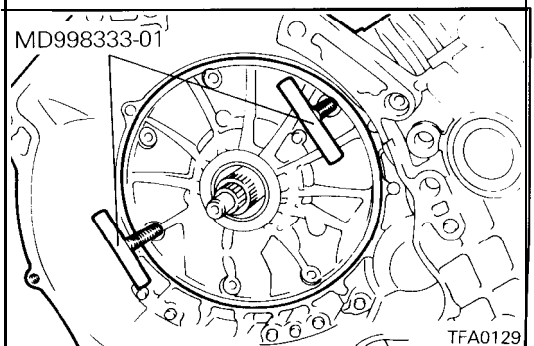

38. Use the special tool to install a new oil pump gasket and oil pump assembly.

Oil pump assembly mounting bolts: 21 Nm (16 ft.lbs.)

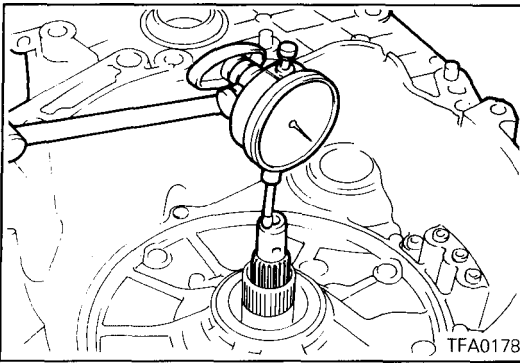

39. Measure the end play of the input shaft. If not the standard value, replace thrust race #3 and thrust washer #1 and adjust to the standard value.

Standard value: 0.3 – 1.0 mm (.012 – .039 in.)

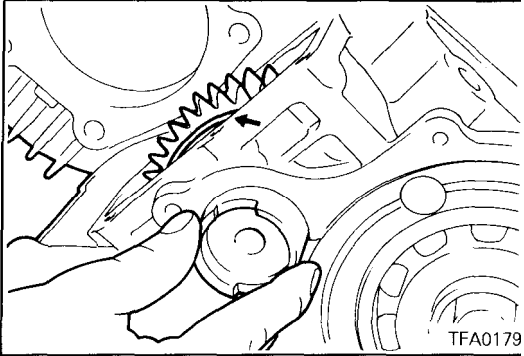

40. Install the spacer, idler gear and bearing and then insert the idler shaft.

Caution

Assemble so that the identification groove on the idler gear faces the rear.

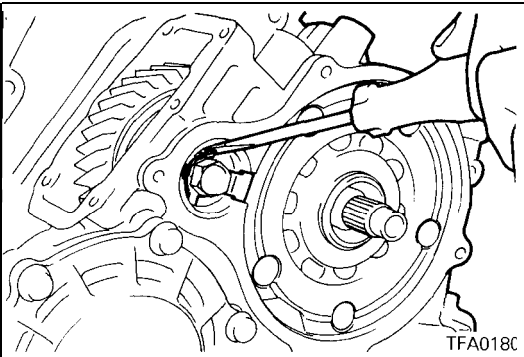

41. Tighten the idler shaft lock bolt together with the new lock plat to the specified torque. Bend the three fingers of the lock plate to prevent turning.

Idler shaft lock bolt: 38 Nm (28 ft.lbs.)

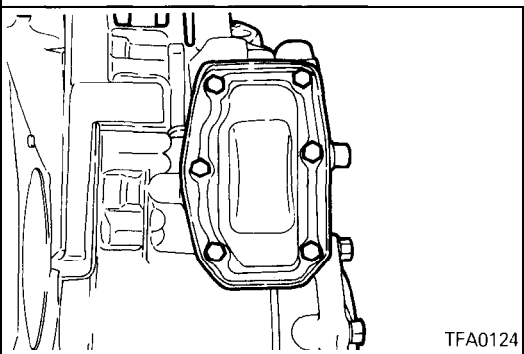

42. Install the idler gear cover and a new gasket.

Idler gear cover mounting bolt: 11 Nm (8 ft.lbs.)

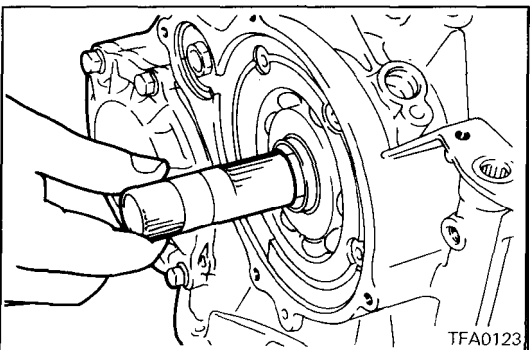

43. Insert the end clutch shaft from the end with the long spline.

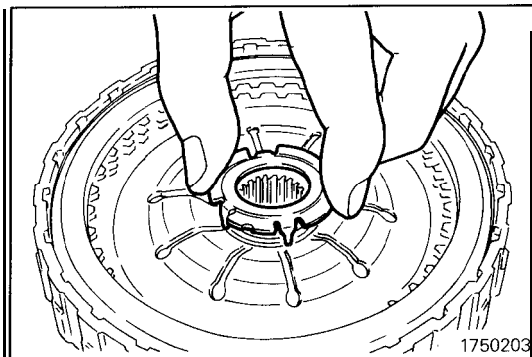

44. Fit the thrust washer on the return spring of the end clutch.

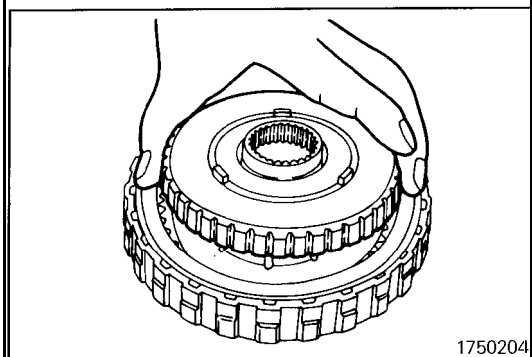

45. Install the end clutch hub on the end clutch assembly.

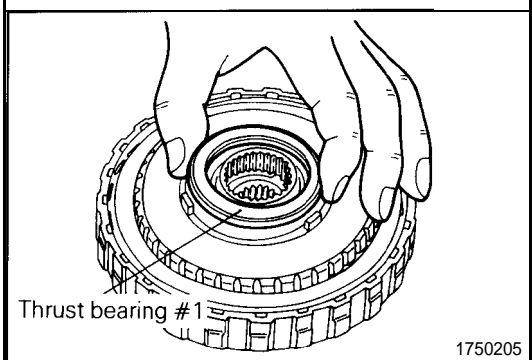

46. Adhere thrust bearing #1 to the end of the clutch hub with petrolatum.

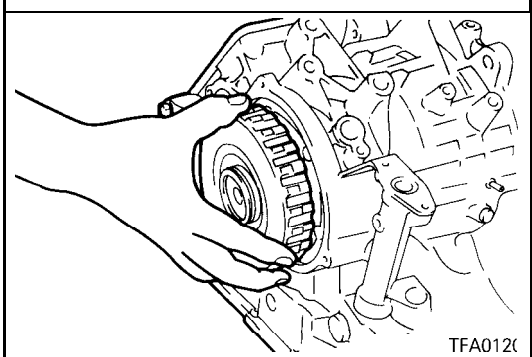

47. Install end clutch assembly.

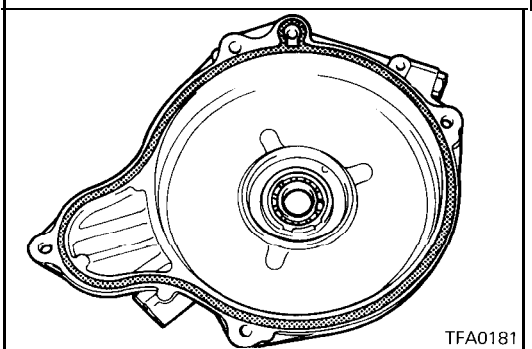

48. Attach a new O-ring to the end clutch cover

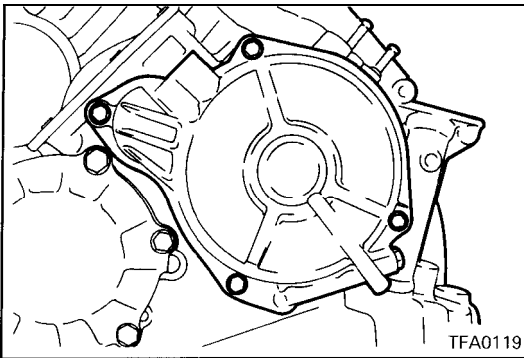

49. Install the end clutch cover and tighten the bolts to the specified torque.

End clutch cover mounting bolts: 11 Nm (8 ft.lbs.)

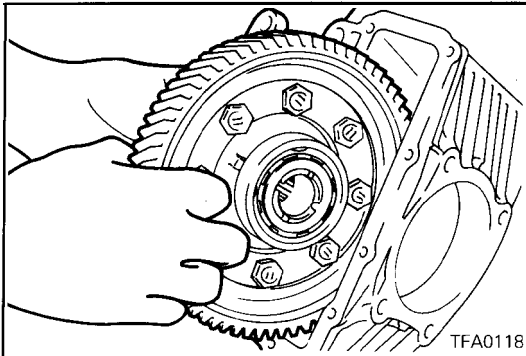

50. Install the differential assembly.

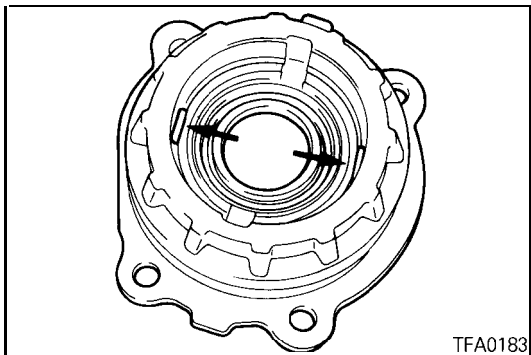

51. Place solder with a length of approximately 10 mm (.39 in.) and diameter of 1.6 mm (.06 in.) on the differential rear bearing retainer at the position shown in the diagram and install the outer race.

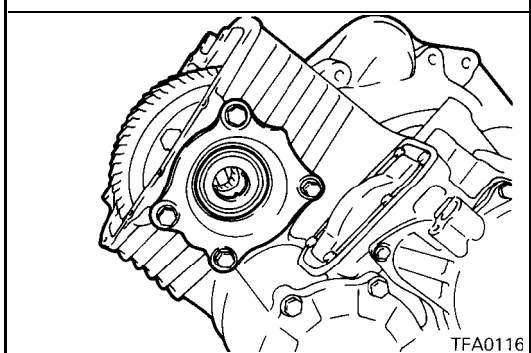

52. Install the differential rear bearing retainer and tighten the bolts to the specified torque.

53. Loosen the bolts, remove the differential rear bearing retainer and remove the solder. If the solder is not crushed, repeat steps (51) – (53). using the solder with the diameter of 3 mm.

**Differential rear bearing retainer mounting bolts:
35 Nm (26 ft.lbs.)**

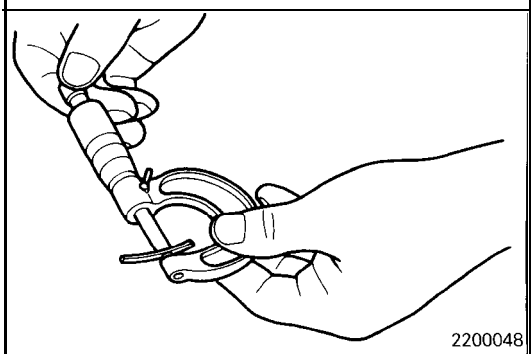

54. Measure the thickness of the crushed solder with a micrometer and adjust by selecting a spacer with a thickness that will provide the standard value for the end play and preload.

Standard value: 0.075 – 0.135 mm (.003 – .0053 in.)

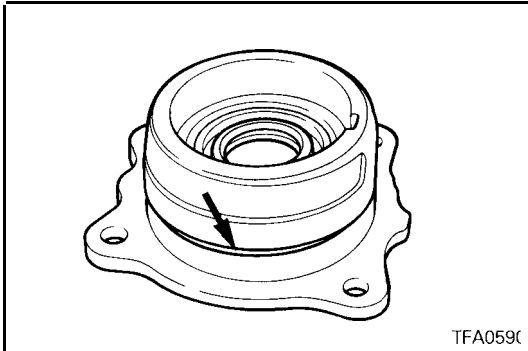

TFA059C

55. Install a new O-ring on the differential rear bearing retainer, coat the O-ring with automatic transmission fluid; then install in the transaxle case and tighten the mounting bolts to the specified torque.

**Differential rear bearing retainer mounting bolts:
35 Nm (26 ft.lbs.)**

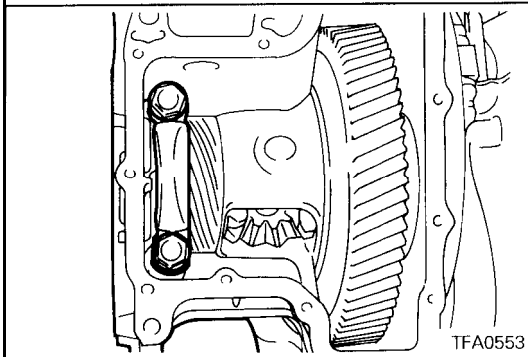

TFA0553

56. Install the front bearing cap and tighten the bolts to the specified torque.

**Differential front bearing cap mounting bolts:
70 Nm (51 ft.lbs.)**

57. Install the differential cover and a new gasket.

Differential cover mounting bolts: 11 Nm (8 ft.lbs.)

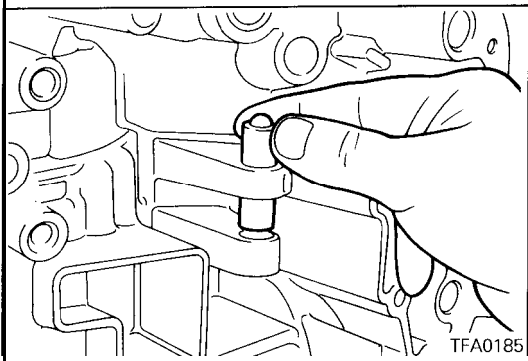

TFA0185

58. Install the detent assembly.

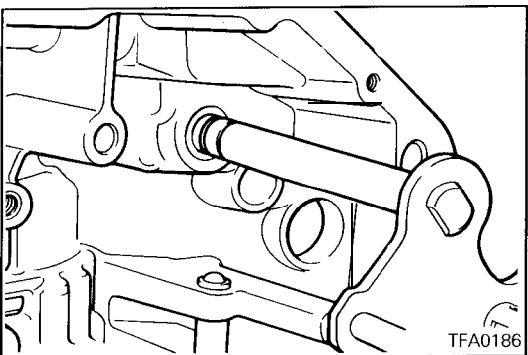

TFA0186

59. Install a new O-ring on the manual control shaft assembly, coat the O-ring with automatic transaxle fluid and then insert into the transaxle case.

60. Align the groove in the manual control shaft and the set screw hole; then install the set screw.

Manual control shaft set screw: 9 Nm (7 **ft.lbs.**)

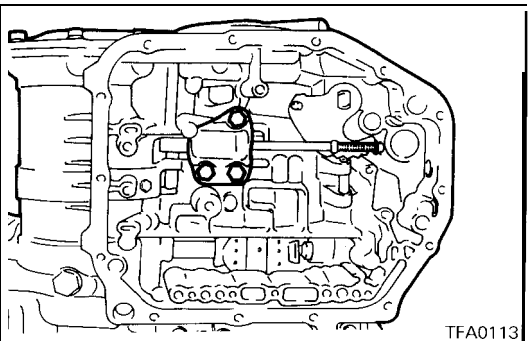

TFA0113

61. Install the parking roller support.

Parking roller support bolts: 24 Nm (18 ft.lbs.)

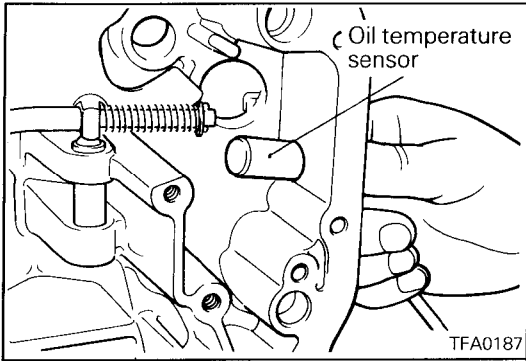

62. Insert the oil temperature sensor into the case.

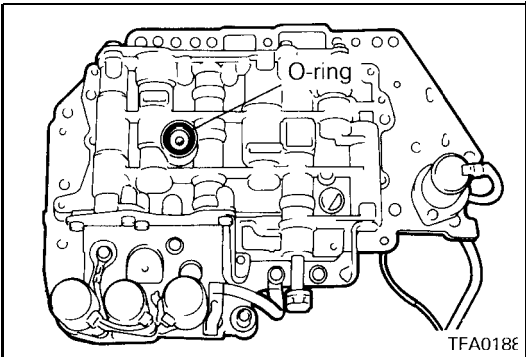

63. Install an O-ring in the O-ring groove at the top of the valve body assembly.

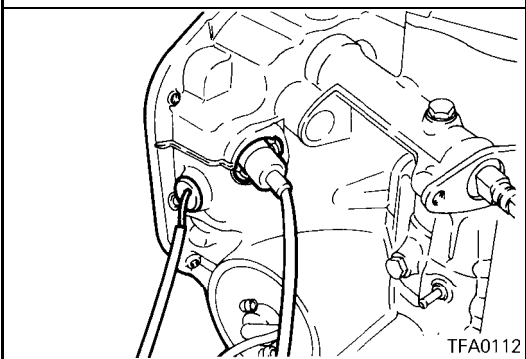

- 64. Replace the solenoid valve harness grommet O-ring with a new one.
- 65. Pass the solenoid valve connector through the transaxle case hole from the inside.
- 66. Push the solenoid valve harness grommet into the case hole.

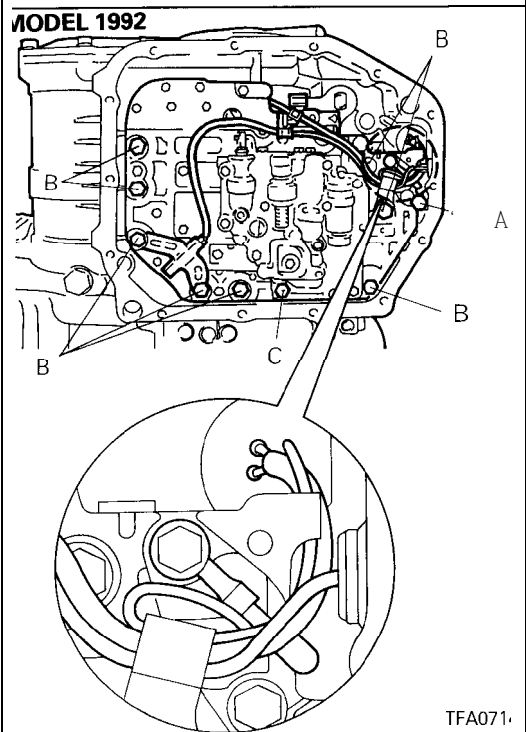

67. Insert the knock pin of the valve body into the case, keeping the detent plate pin in the manual valve groove. Temporarily install the valve body, install the oil temperature sensor and holder; then tighten the mounting bolts to the specified torque.

A bolt: 18 mm (.709 in.)

B bolt: 25 mm (.984 in.)

C bolt: 40 mm (1.575 in.)

Valve body assembly mounting bolts: 11 Nm (8 ft.lbs.)

Caution

Firmly fasten the solenoid valve and oil temperature sensor harness at the position shown in the diagram. Especially, be sure to route the pressure control solenoid valve (PCSV) harness, which is separated from other harness, as shown in the diagram and fasten the harness with a clamp, Failure to fasten it may result in contact with the detent plate or parking rod.

MODEL 1993

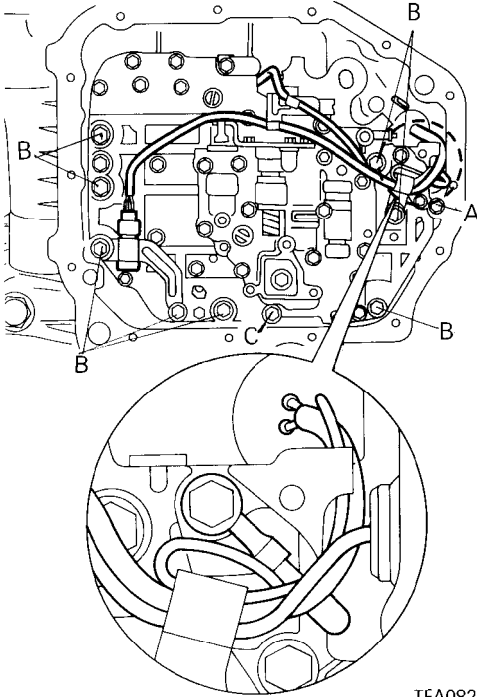

TFA0824

68. Install the oil screen.

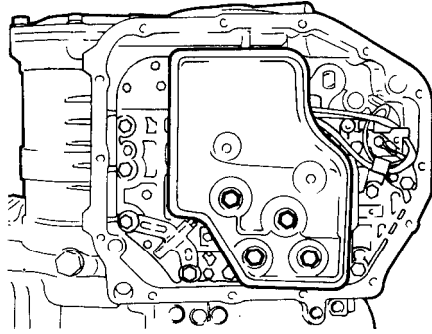
Oil filter mounting bolts: 6 Nm (5 ft.lbs.)

TFA0106

69. Install the magnets in the oil pan and install the oil pan.

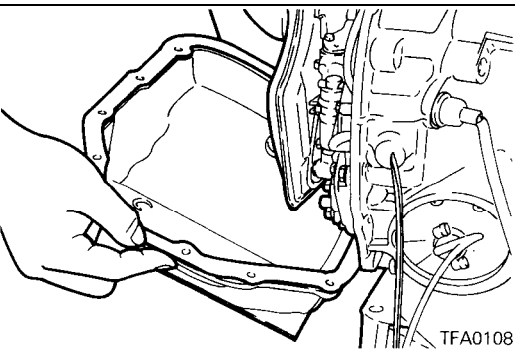
Oil pan mounting bolts: 11 Nm (8 ft.lbs.)

TFA0108

MODEL 1992

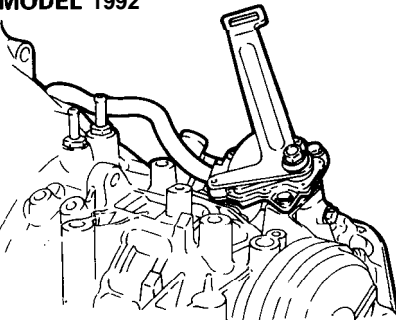

TFA0107

70. Install park/neutral position switch (PNP switch) and manual control lever.

Park/neutral position switch mounting bolts:**11 Nm (8 ft.lbs.)****Manual control lever mounting bolt: 19 Nm (14 ft.lbs.)**

71. Install the speedometer gear assembly.

Speedometer gear locking plate mounting bolt:

5 Nm (4 ft.lbs.)

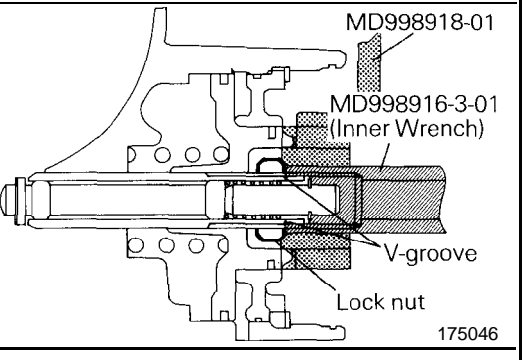
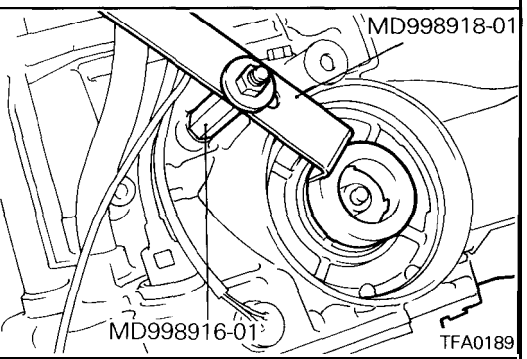
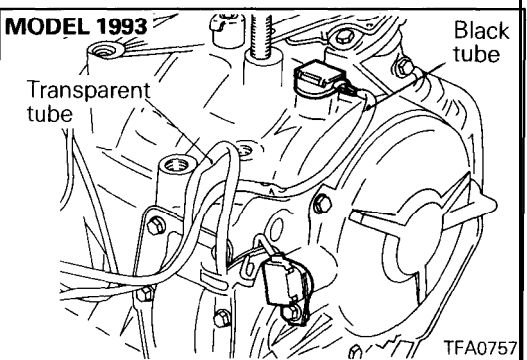
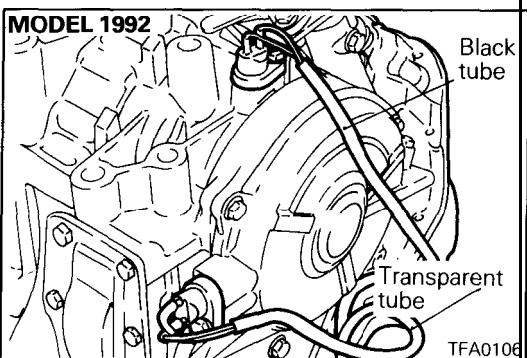
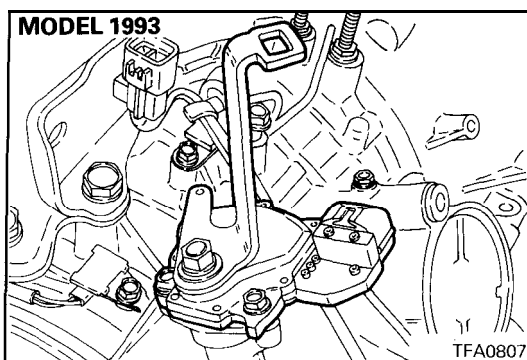

72. Install the pulse generator A and B.

Pulse generator mounting bolts: 11 Nm (8 ft.lbs.)

Caution

Install the black tube on the output gear side and the transparent tube on the end clutch side.

73. Install the oil filler tube and insert the level gauge.

Oil filter tube mounting bolt: 24 Nm (18 ft.lbs.)

74. Install the brackets.

Transaxle mounting bracket bolts: 70 Nm (51 ft.lbs.)

75. Adjust the kickdown servo.

76. Adjust the kickdown servo by the following procedure:

- (a) Fit the claw of the special tool in the notch of the piston to prevent the piston from turning, and use adapter to secure it as illustrated at left.

Caution

- 1. Do not push in the piston with the special tool.
- 2. **When the adapter is installed to the transaxle case, do not apply excessive torque but tighten with a hand.**

- (b) Loosen the lock nut until it is about to reach the V groove in the adjusting rod. Tighten the special tool (inner) until it touches the lock nut.

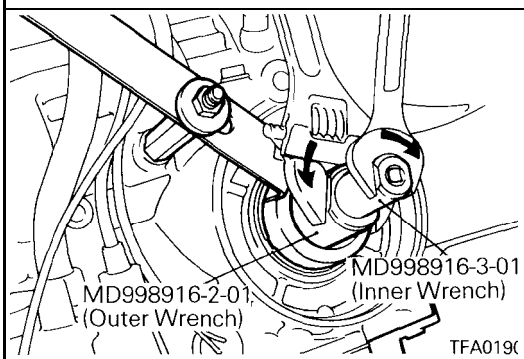

- (c) Fit the special tool (outer) to the lock nut. Turn the outer cylinder counterclockwise and the inner cylinder clockwise to lock the lock nut and the special tool (inner).

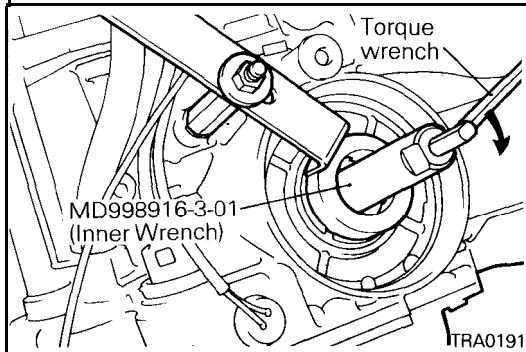

- (d) Fit torque wrench to the special tool (inner) to tighten it to a torque of 10 Nm (7.2 ft.lbs.) and loosen. Repeat this sequence two times before tightening the special tool (inner) to 5 Nm (3.6 ft.lbs.) torque. Then back off the special tool (outer) 2 to 2¼ turns.

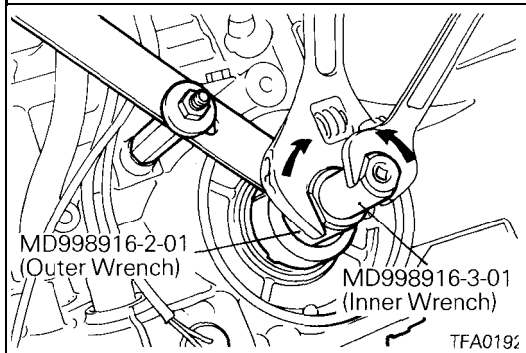

- (e) Fit the special tool (outer) to the lock nut. Turn the outer cylinder clockwise and the inner cylinder counterclockwise to unlock the lock nut and the special tool (inner).

Caution

When unlocking is carried out, apply equal force to both special tools to loosen.

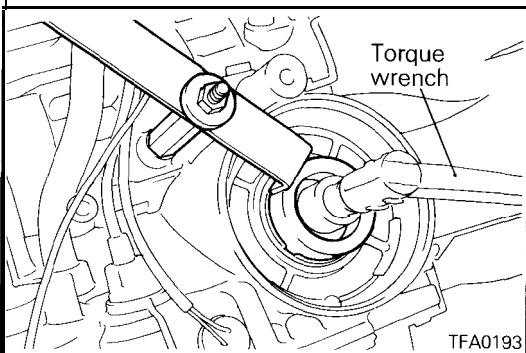

- (f) Tighten the lock nut with a hand until it touches the piston. Then, use torque wrench to tighten the lock nut to specified torque.

Lock nut: 29 Nm (21 ft.lbs.)

Caution

The lock nut may turn with the adjusting rod if tightened quickly with socket wrench or torque wrench.

- (g) Remove the special tool for securing the piston. Install the plug to the Low/Reverse pressure outlet and tighten to specified torque.

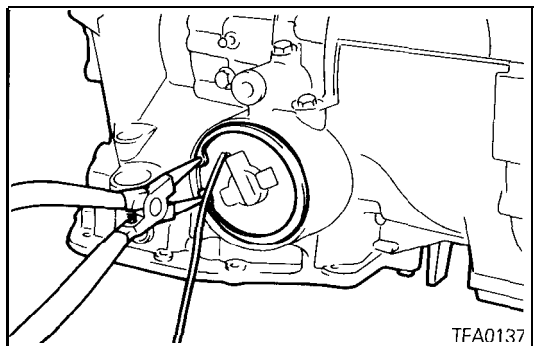

77. Install the kickdown servo switch and fasten with a snap ring.

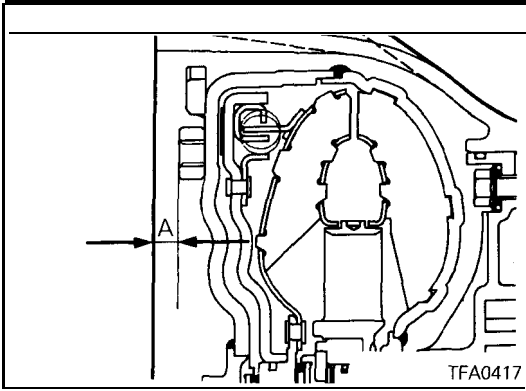

78. Coat the oil pump drive hub with automatic transmission fluid and install the torque converter. Push in firmly so that dimension A in the diagram is the standard value.

Standard value: approx. 16.3 mm (.642 in.)

**TRANSAXLE (4WD)
COMPONENTS**

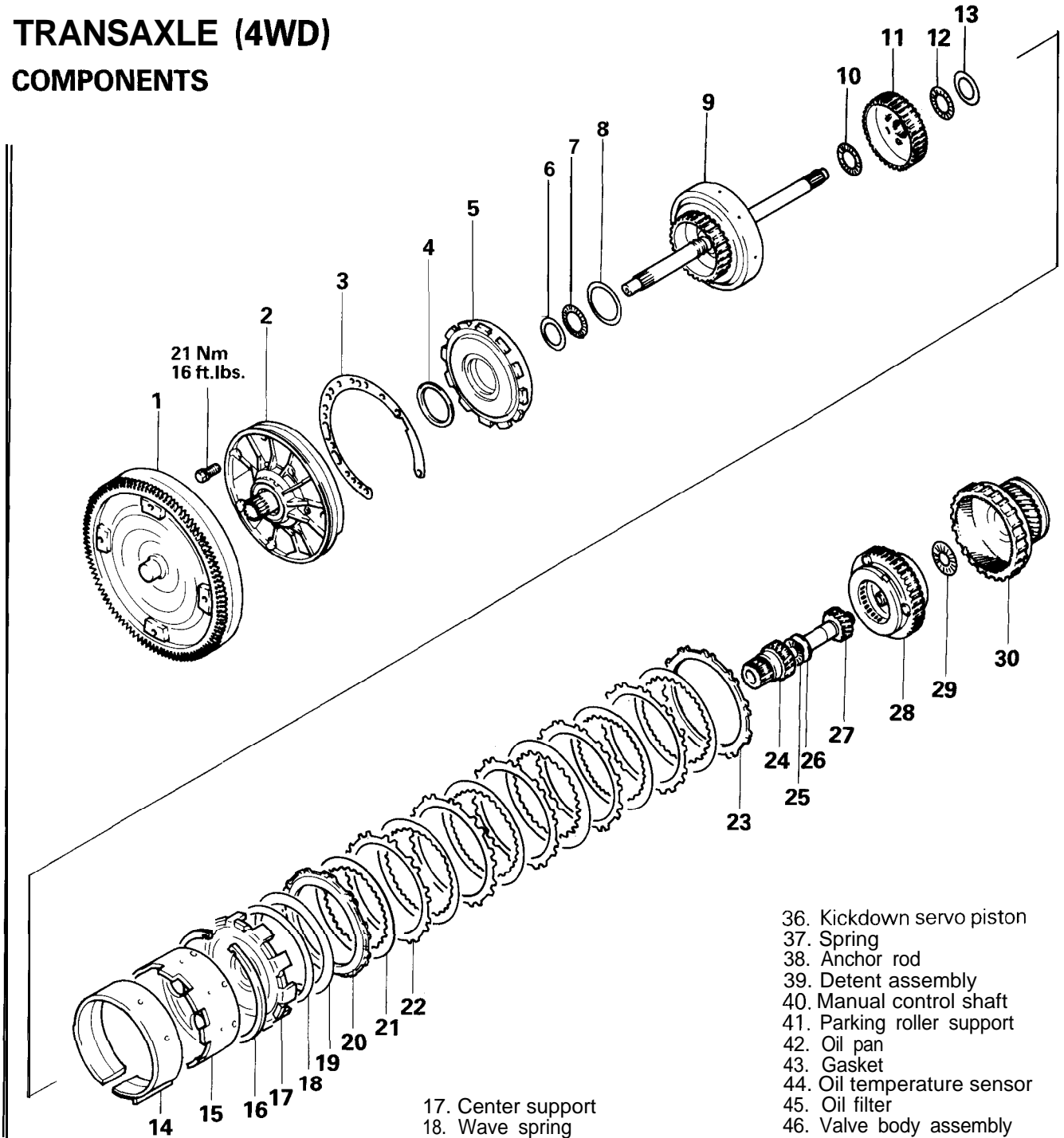

- 1. Torque converter
- 2. Oil pump assembly
- 3. Gasket
- 4. Thrust washer #1
- 5. Front clutch assembly
- 6. Thrust race #3
- 7. Thrust bearing #4
- 8. Thrust washer #2
- 9. Rear clutch assembly
- 10. Thrust bearing #5
- 11. Rear clutch hub
- 12. Thrust bearing #7
- 13. Thrust race #6
- 14. Kickdown band
- 15. Kickdown drum
- 16. Snap ring

- 17. Center support
- 18. Wave spring
- 19. Return spring
- 20. Pressure plate
- 21. Brake disc
- 22. Brake plate
- 23. Reaction plate
- 24. Reverse sun gear
- 25. Thrust bearing #8
- 26. Thrust race #9
- 27. Forward sun gear
- 28. Planetary carrier assembly
- 29. Thrust bearing #10
- 30. Output flange
- 31. Oil level gauge
- 32. Oil filler tube
- 33. Snap ring
- 34. Kickdown servo switch
- 35. Snap ring

- 36. Kickdown servo piston
- 37. Spring
- 38. Anchor rod
- 39. Detent assembly
- 40. Manual control shaft
- 41. Parking roller support
- 42. Oil pan
- 43. Gasket
- 44. Oil temperature sensor
- 45. Oil filter
- 46. Valve body assembly
- 47. Manual control lever
- 48. Park/neutral position switch (PNP switch)
- 49. End clutch shaft
- 50. Bearing retainer
- 51. Thrust bearing #11
- 52. End clutch hub
- 53. Thrust washer
- 54. End clutch assembly
- 55. O-ring
- 56. End clutch cover
- 57. Pulse generator
- 58. Lock bolt
- 59. Idler shaft
- 60. Idler gear
- 61. Spacer
- 62. Gasket

TSB Revision

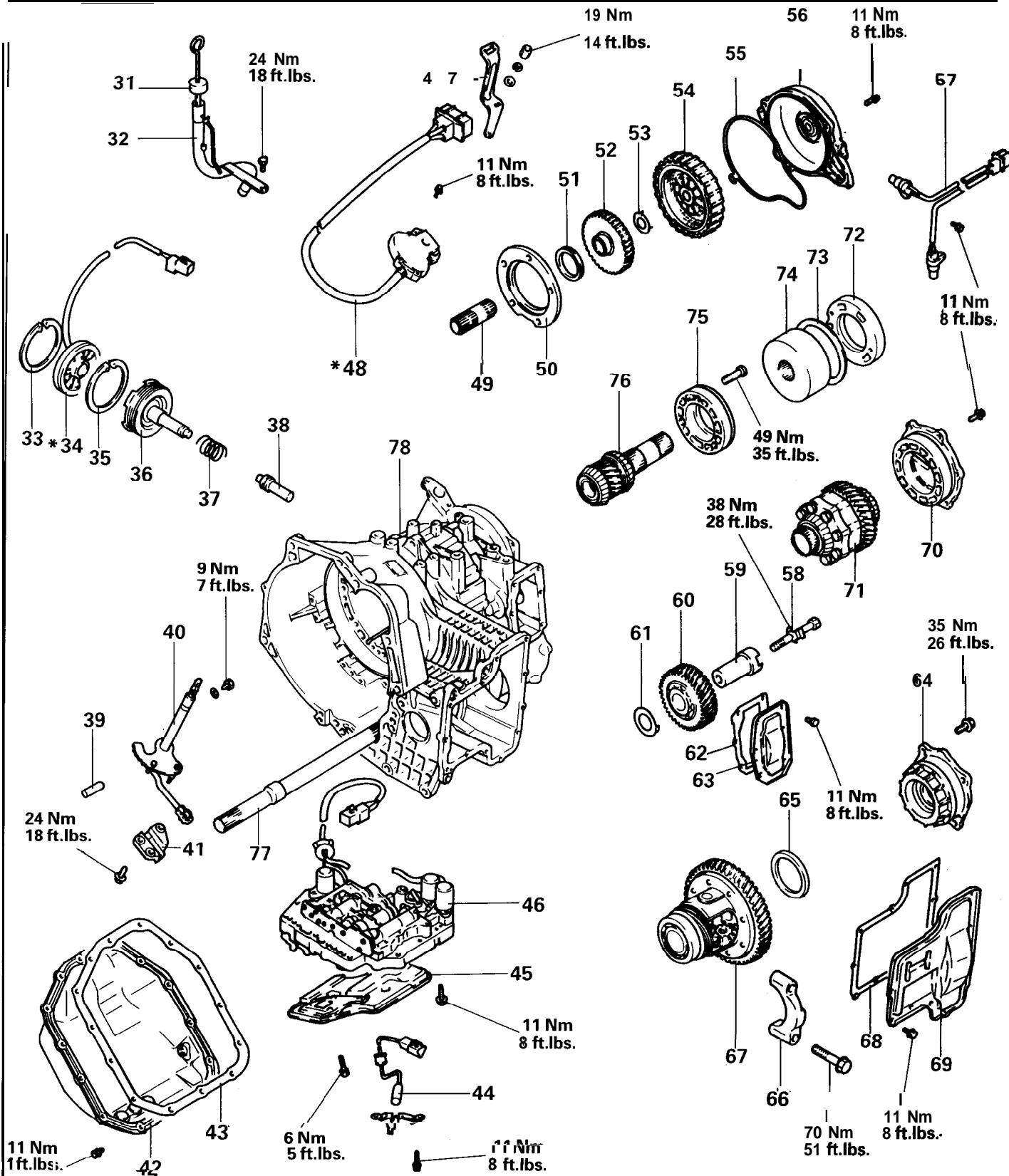

- 68. Idler gear cover
- 69. Differential cover
- 70. Output bearing retainer
- 71. Center differential assembly
- 72. Center bearing retainer
- 73. Stopper ring
- 74. Viscous coupling unit
- 75. Center bearing retainer
- 76. Front output shaft
- 77. Rear output shaft
- 78. Transaxle case

NOTE:
On 1993 and subsequent models, *-marked parts have the connector directly attached, not via a harness.

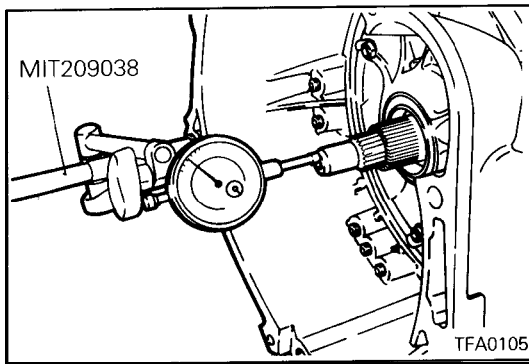
**DISASSEMBLY**

1. Clean away any sand, mud, etc. adhered around the transaxle.
2. Place the transaxle assembly on the workbench with the oil pan down.
3. Remove the torque converter.
4. Use the special tool to mount the dial gauge on the transaxle case and measure the end play of the input shaft.

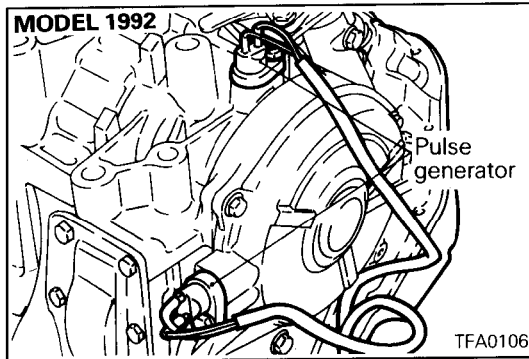

5. Remove the pulse generator "A" and "B"

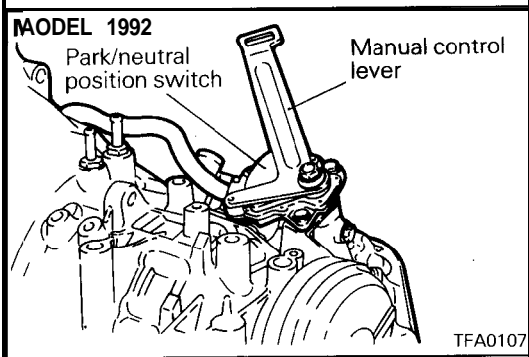
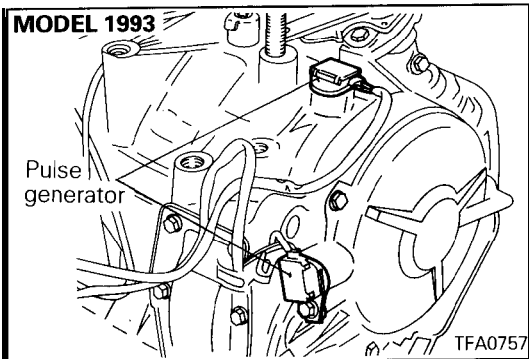

6. Remove manual control lever then remove park/neutral position switch (PNP switch).

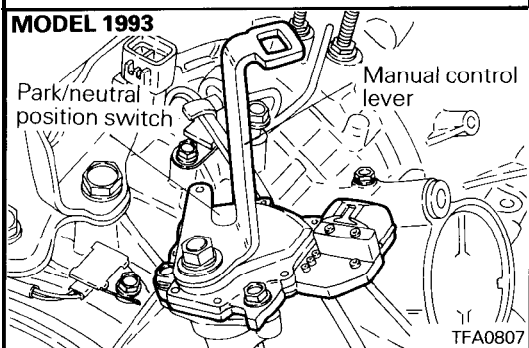

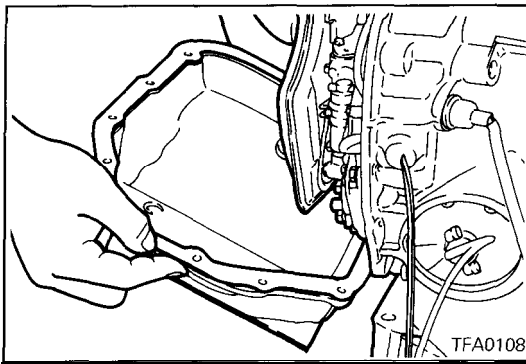

7. Remove the oil pan, magnets and gasket,

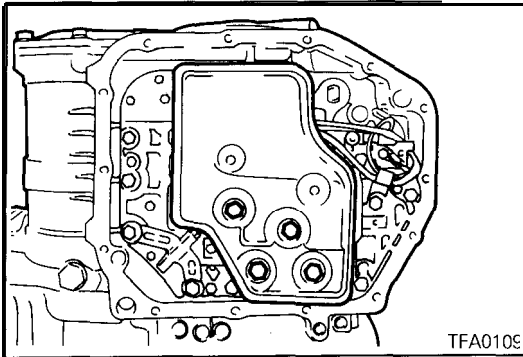

8. Remove the oil filter from the valve body.

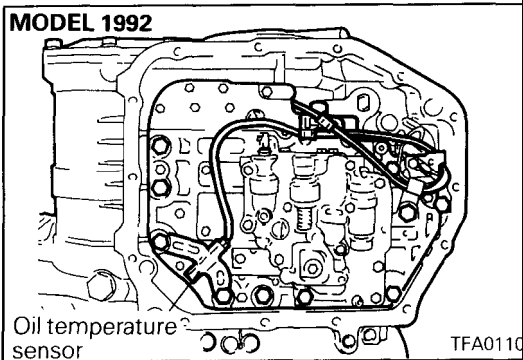

9. Remove the 10 valve body mounting bolts.

10. Remove the oil temperature sensor holder and remove the oil temperature sensor harness from the clamp.

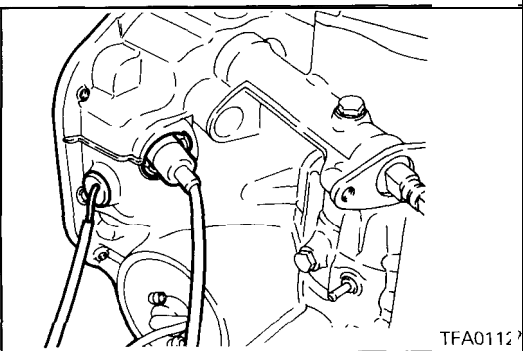
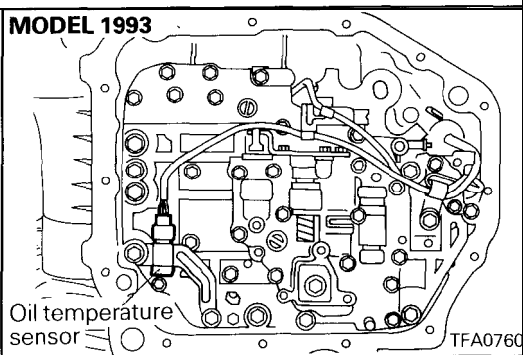

11. Press the finger of the solenoid valve harness grommet, push the grommet into the case and remove the valve body assembly.

12. Pull out the oil temperature sensor.

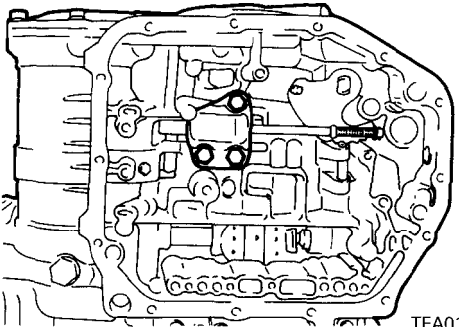

13. Remove the parking roller support.

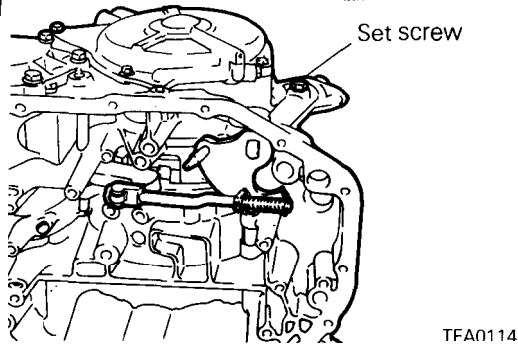

14. Remove the set screw of the manual control shaft and remove the manual control shaft assembly.

15. Remove the detent assembly.

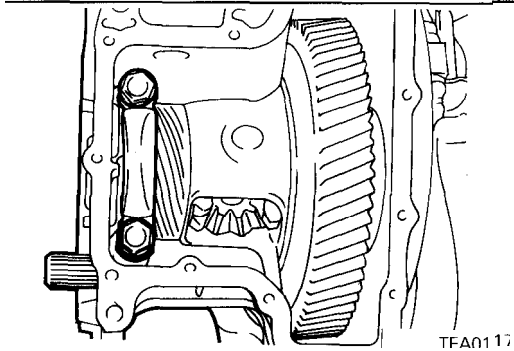

16. Remove the differential cover and gasket.

17. Remove the differential front bearing cap.

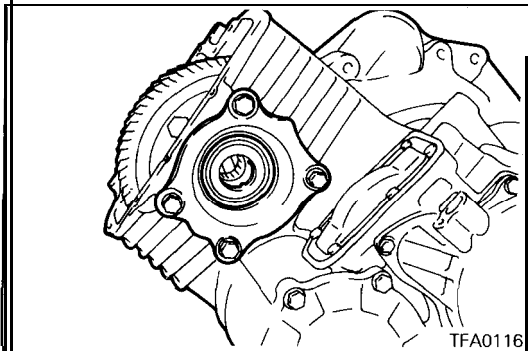

18. Remove the differential bearing retainer, spacer and outer race.

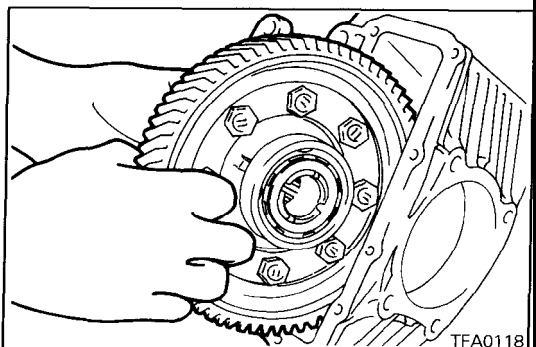

19. Remove the differential assembly.

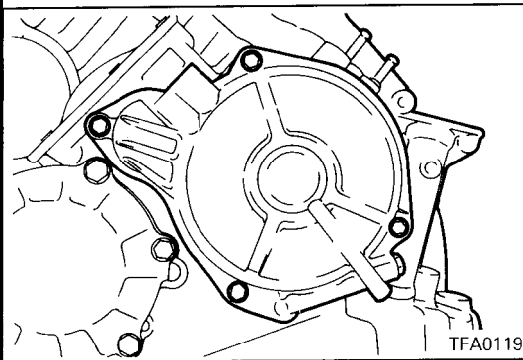

20. Take out the end clutch cover installation bolts, then remove the cover holder and end clutch cover.

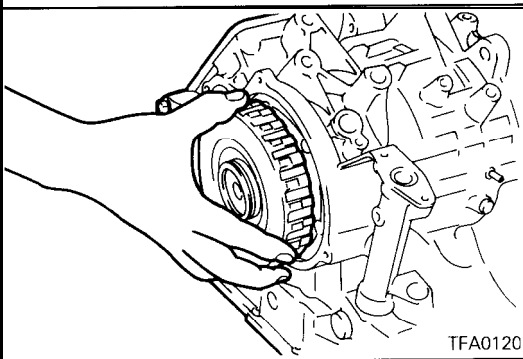

21. Remove the end clutch assembly.

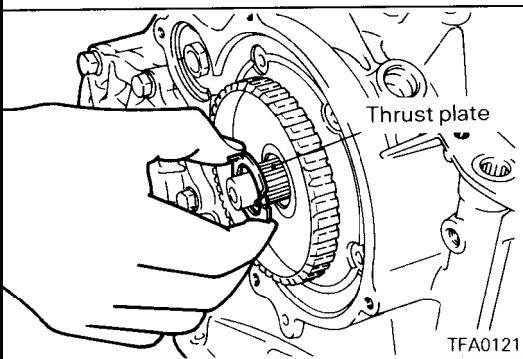

22. Remove the thrust plate.

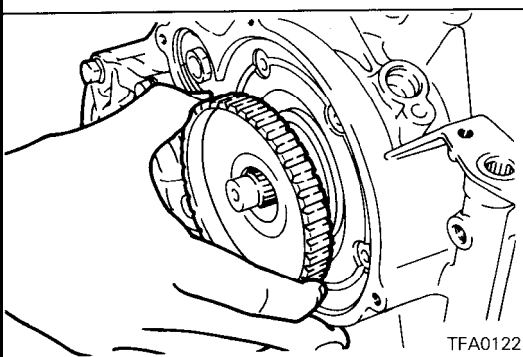

23. Remove the end clutch hub.

24. Remove the thrust bearing #11.

NOTE

It may be stuck to the end clutch hub.

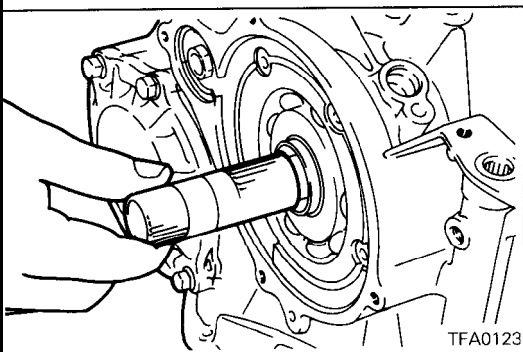

25. Pull out the end clutch shaft

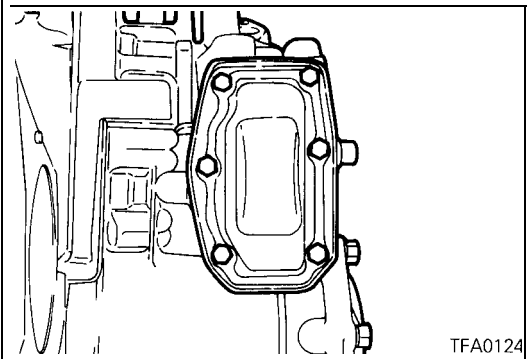

26. Remove the idler gear cover mounting bolts, then remove the idler gear cover and gasket.

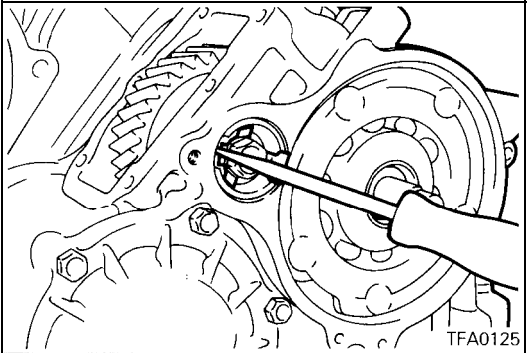

27. Disengage the bolt stopper and remove the bolt.

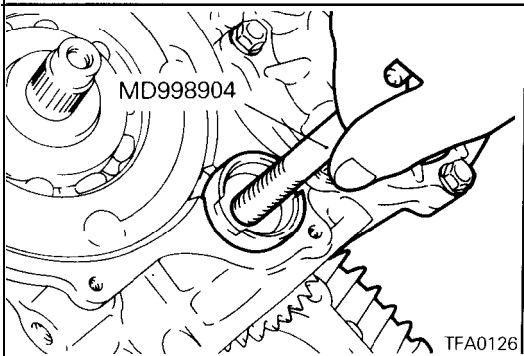

28. Using the special tool, pull out the idler shaft and then remove the idler gear and bearing inner race.

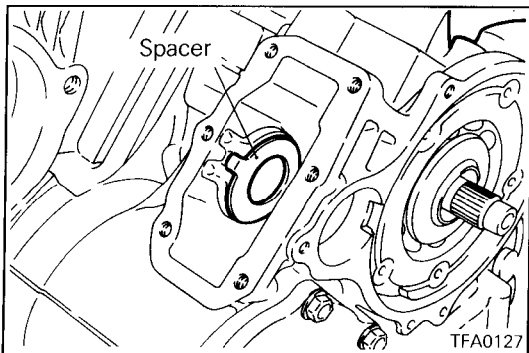

29. Remove the spacer

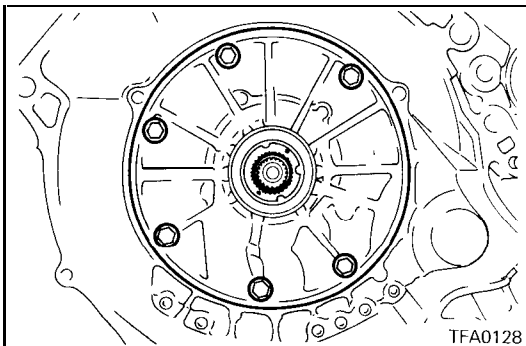

30. Remove oil pump installation bolts.

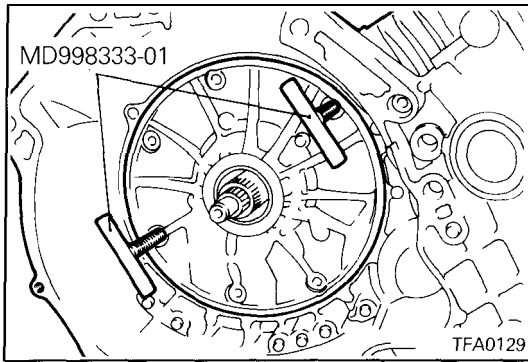

31. Use the special tool and remove the oil pump.

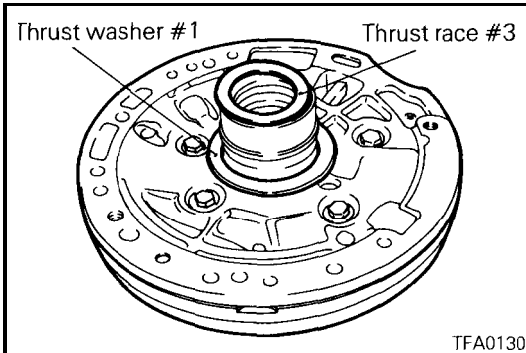

32. Remove thrust washer #1 and thrust race #3.

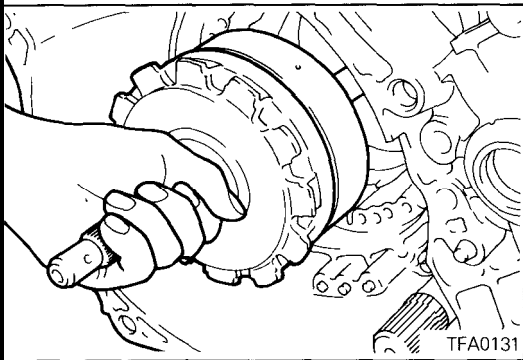

33. Hold the input shaft and remove the front clutch assembly and rear clutch assembly together.

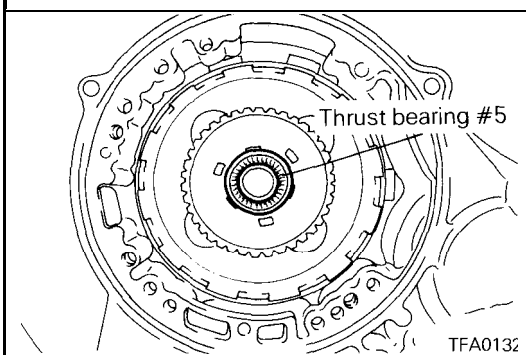

34. Remove the thrust bearing #5

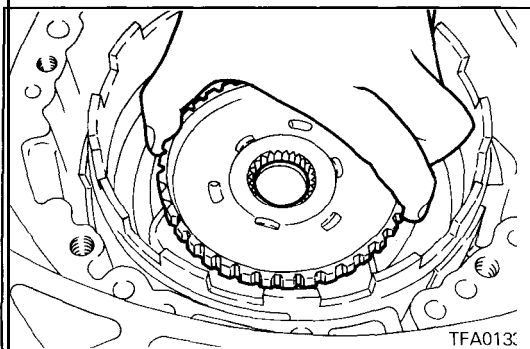

35. Remove the clutch hub.

NOTE

The thrust race may be stuck to the clutch hub.

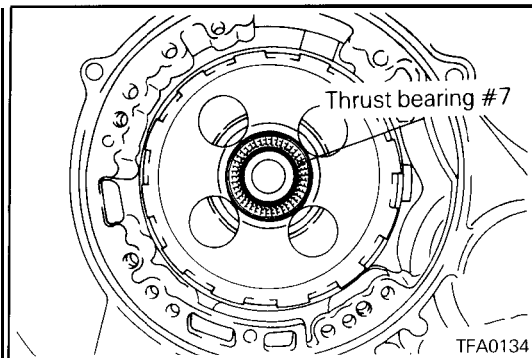

36. Remove the thrust bearing #7

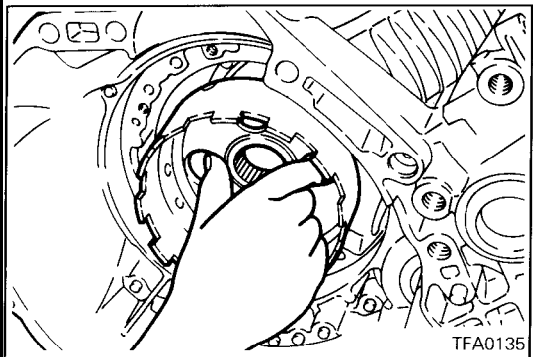

37. Remove the kickdown drum.

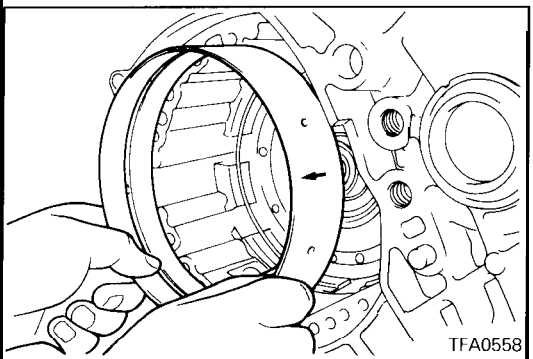

38. Remove the kickdown band.

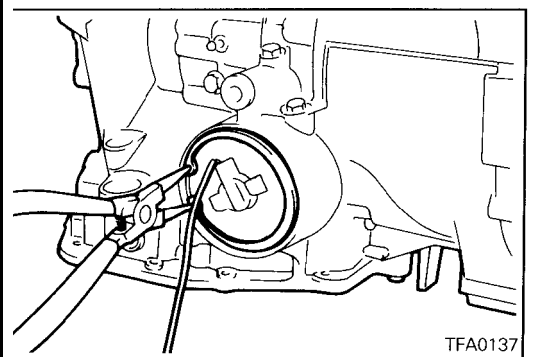

39. Remove the kickdown servo cover snap ring. Then remove the kickdown servo switch.

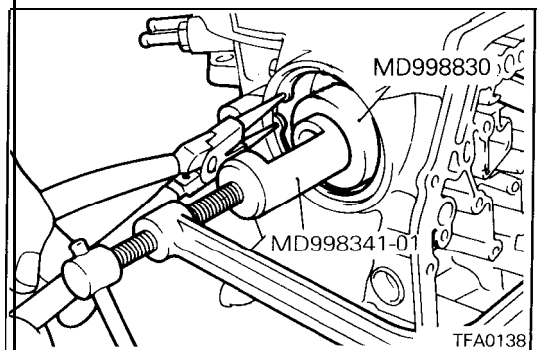

40. Using the special tool, push in the kickdown servo and remove the snap ring.

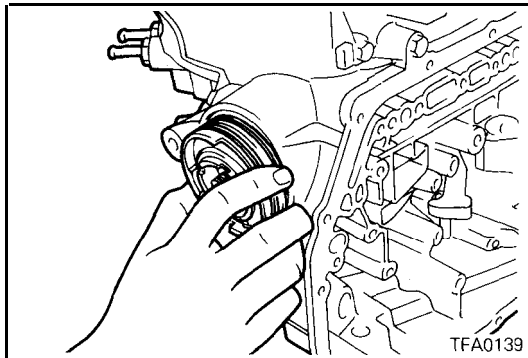

41. Remove the kickdown servo piston.

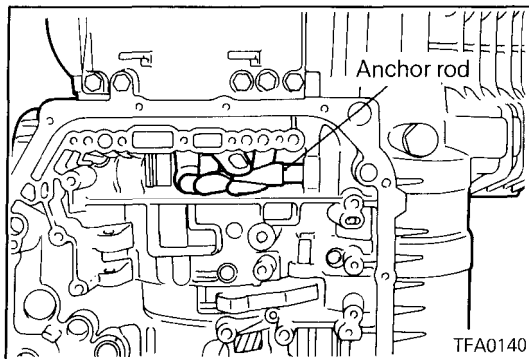

42. Remove the anchor rod.

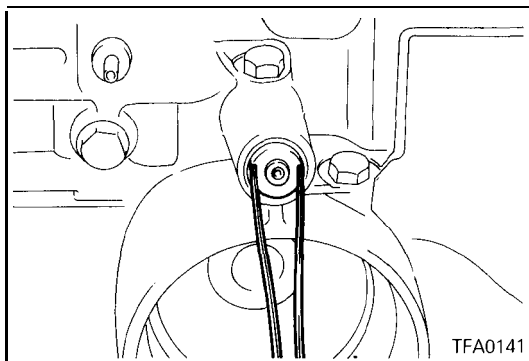

43. Remove the plug, then remove the air exhaust plug.

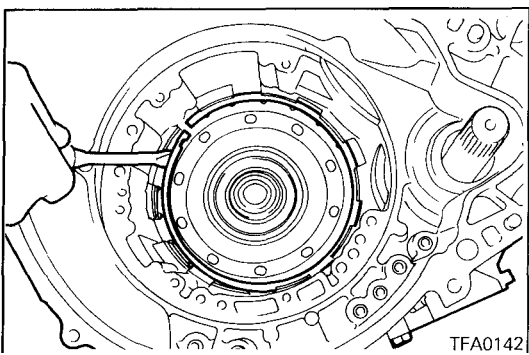

44. Remove the snap ring.

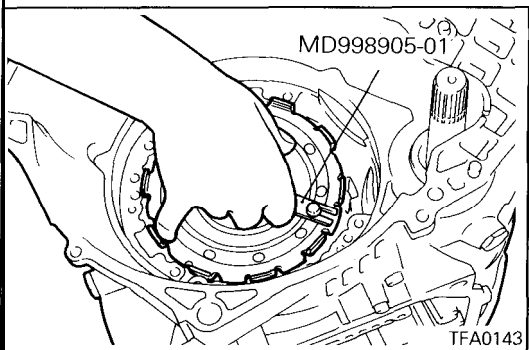

45. Using the special tool, remove the center support.

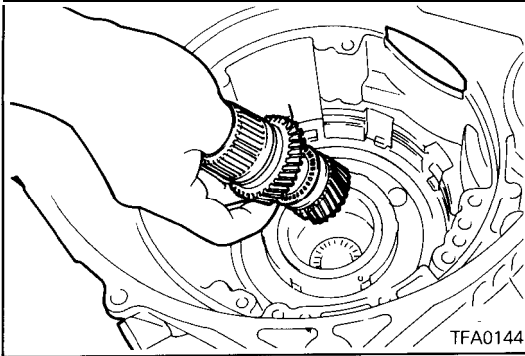

46. Remove reverse sun gear and forward sun gear together.

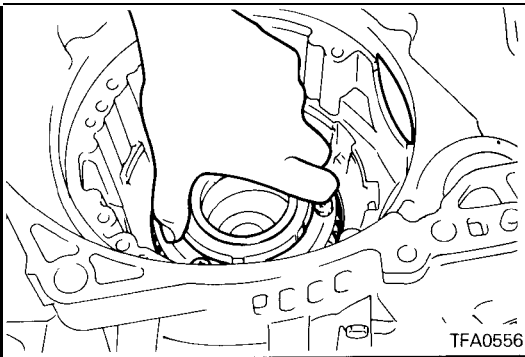

47. Remove planet carrier assembly.

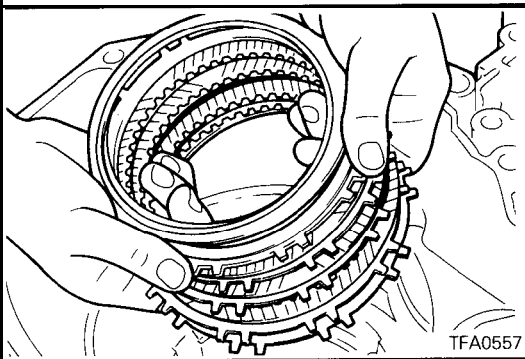

48. Remove the wave spring, return spring, reaction plate, brake discs, and brake plates.

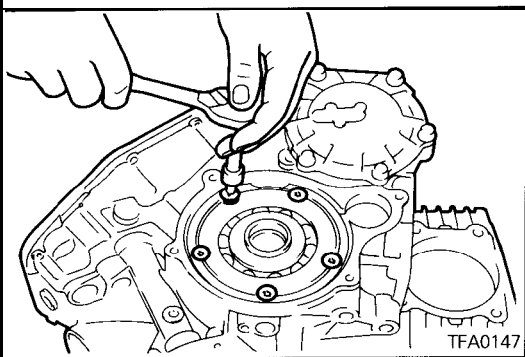

49. Remove the screws and the rear bearing retainer.

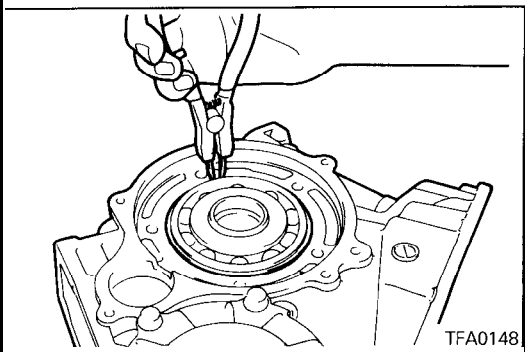

50. Remove the snap ring and then remove the output flange assembly.

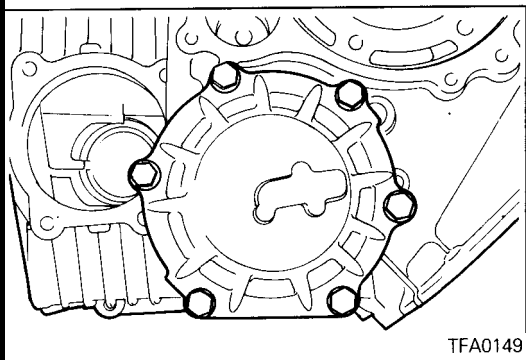

51. Remove the output bearing retainer mounting bolts and then remove the output bearing retainer and outer race.

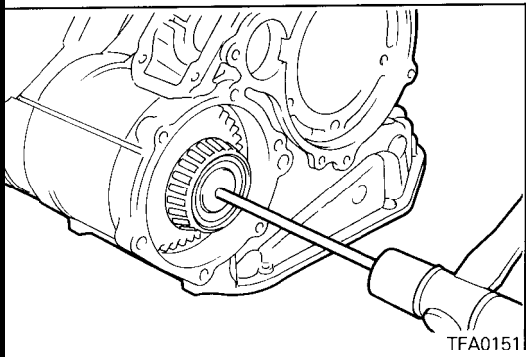

52. Insert a rod 8 mm (.31 in.) in diameter and 200 mm (7.87 in.) in length from the hole shown in the figure and punch out the rear output shaft.

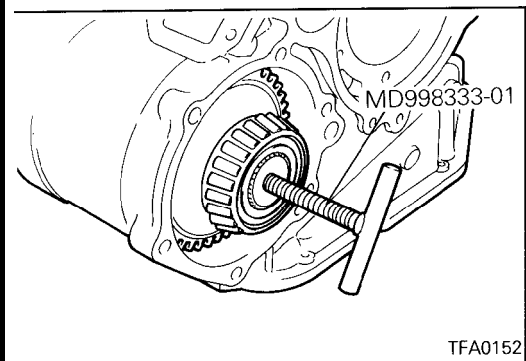

53. Using the special tool, remove the center differential.

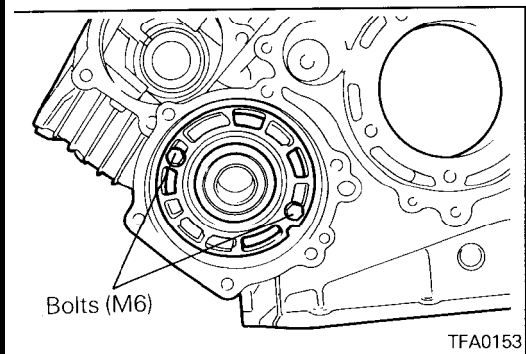

54. Put a bolt (M6) into the center bearing retainer and, holding that bolt, remove the center bearing retainer and outer race.

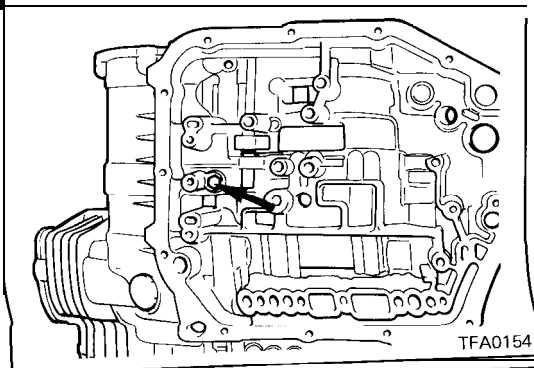

55. Remove the center bearing retainer stopper bolt.

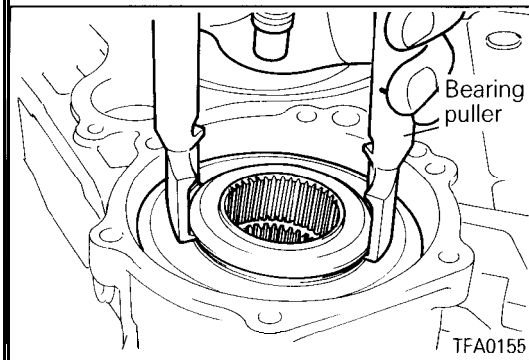

56. First remove the stopper ring and then put a bearing puller or similar tool in the viscous coupling groove and pull out the viscous coupling.

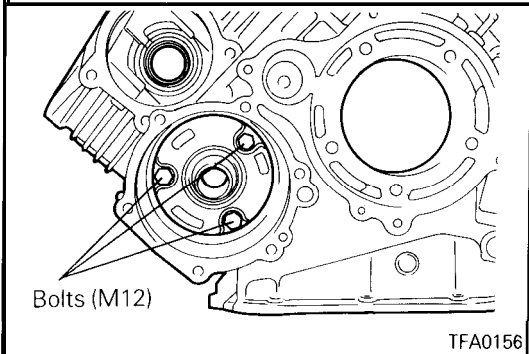

57. Remove the front bearing retainer mounting bolt (M10). Then, screw a bolt (M12) into the threaded hole of the front bearing retainer and, holding that bolt, remove the front bearing retainer and outer race.

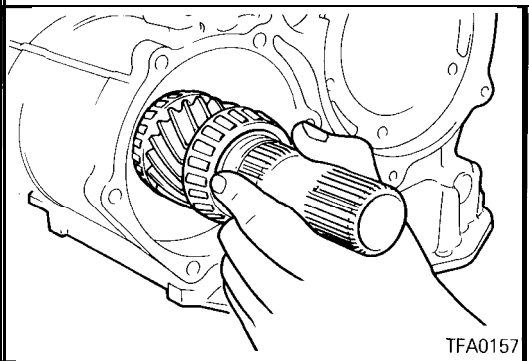

58. Remove the front output shaft.

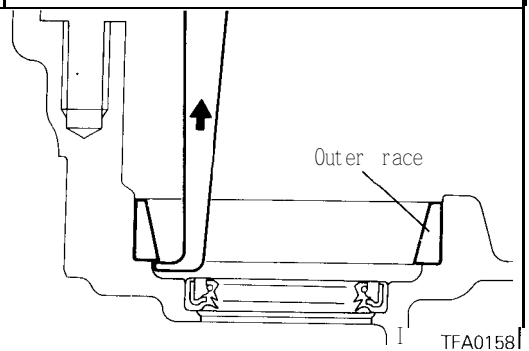

59. Using a sliding hammer or similar tool, remove the outer race.

60. Remove the oil seals.

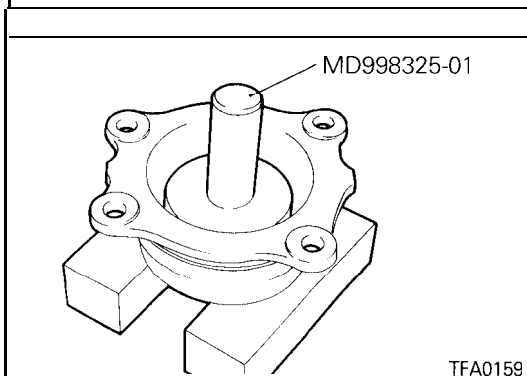

REASSEMBLY

1. Using the special tool, install the oil seals to the differential bearing retainer and transaxle case.

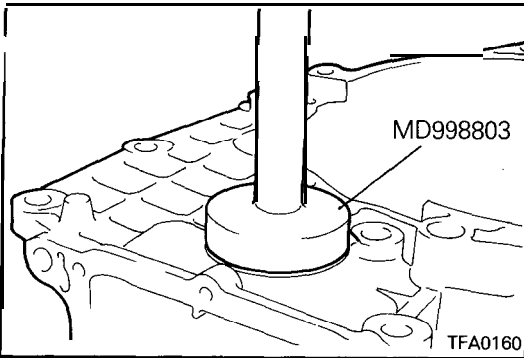

- Using the special tool, install the rear output shaft oil seal.

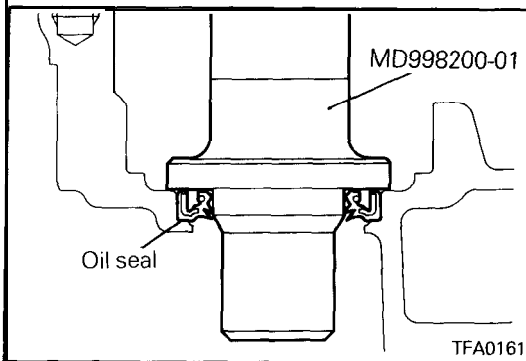

- Using the special tool, press-fit the outer race in the transaxle case.

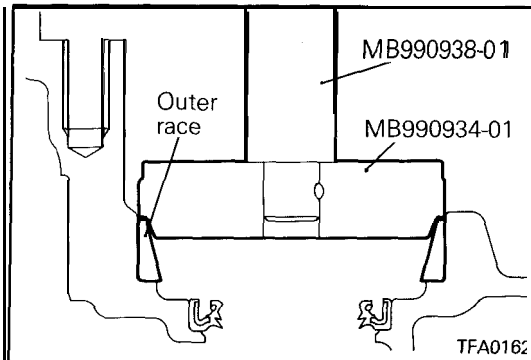

- Install the front output shaft assembly.

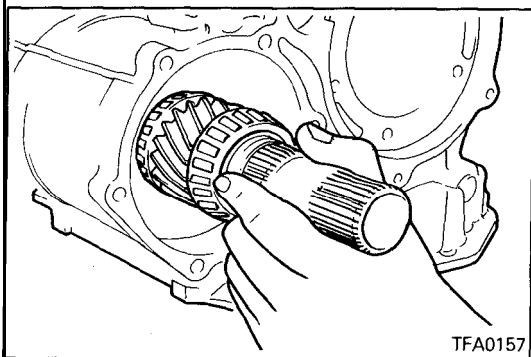

- Position the solder approx. 10 mm (40 in.) long by 1.6 mm (.06 in.) in diameter in the front bearing retainer in the position shown in the figure and then install the outer race.

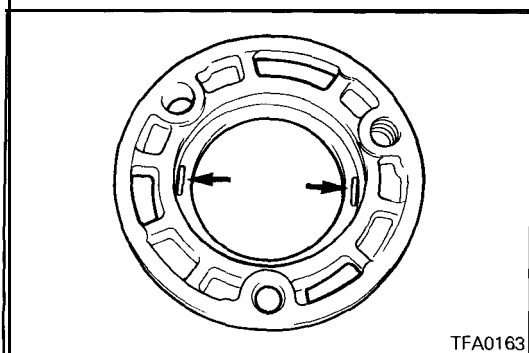

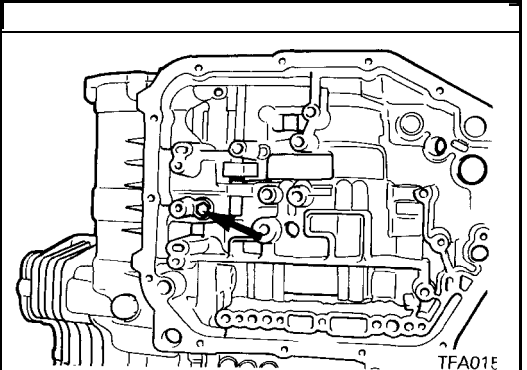
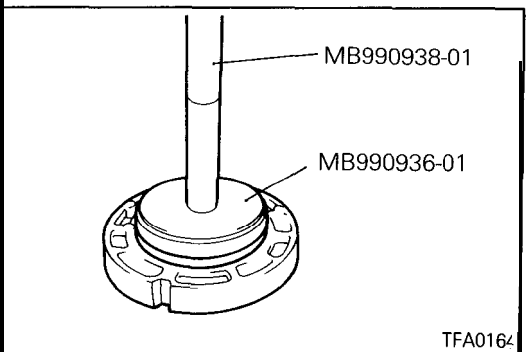
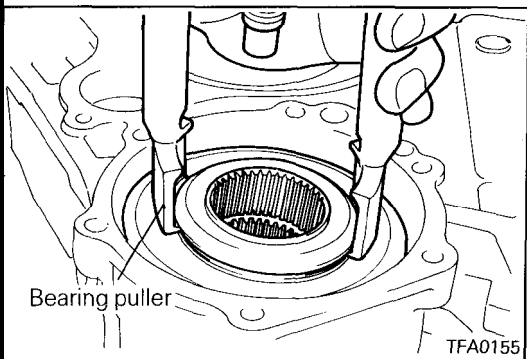
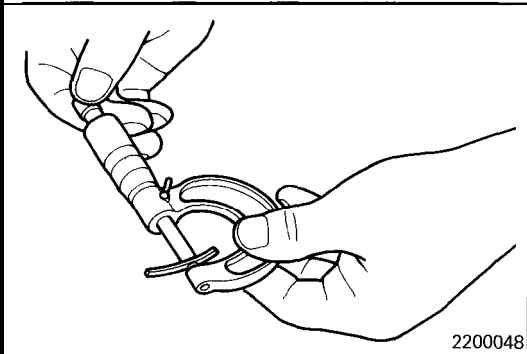
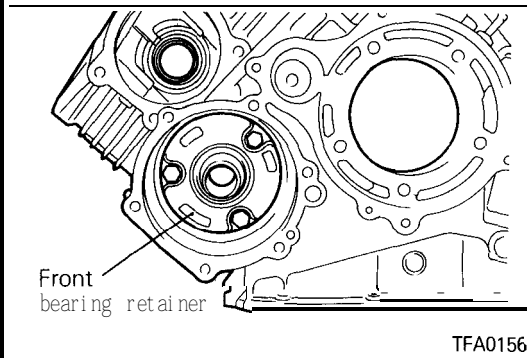

6. Install the front bearing retainer and tighten the bolt with the specified torque.

**Front bearing retainer mounting bolts:
49 Nm (35 ft.lbs.)**

7. Loosen the bolts and remove the front bearing retainer.
8. Remove the outer race from the front bearing retainer and remove the solder. If the solder does not break, perform the work in steps 5 – 8 with large diameter solder. Measure the thickness of the crushed solder with a micrometer and select a spacer with the correct thickness so the preload reaches the standard value.

Standard value: 0.055 – 0.115 mm (.0022 – .0045 in.)

9. Install the spacer selected in the previous step and the outer race in the front bearing retainer.
10. First install the front bearing retainer and apply sealant to the bolts and then tighten with the specified torque.

Specified sealant:

**3M Stud Locking Part No. 4170 or equivalent
Front bearing retainer mounting bolts:
49 Nm (35 ft.lbs.)**

11. Using a bearing puller, support the viscous coupling and insert in the case. Then, install the stopper ring.

12. Using the special tool, install the outer race in the center bearing retainer.

13. Install the center bearing retainer stopper bolt.

Center bearing retainer stopper bolt: 5 Nm (4 ft.lbs.)

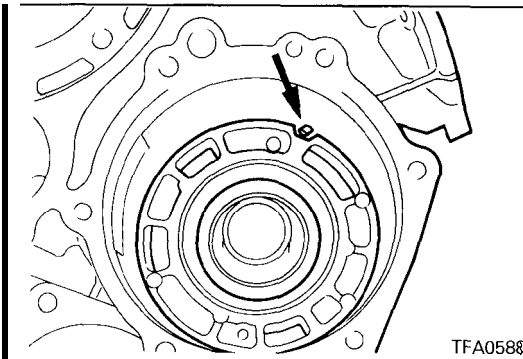

14. Install the center bearing retainer so the projection of the stopper bolt fits in the groove of the center bearing retainer.

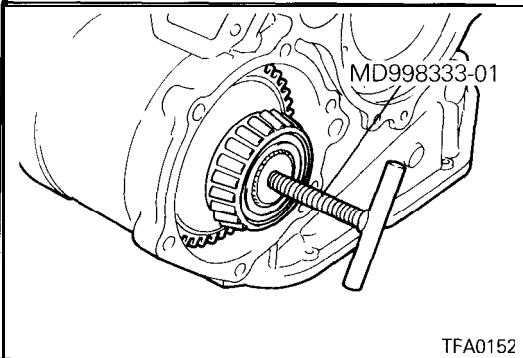

15. Install the special tool in the center differential and install the center differential in the transaxle case.

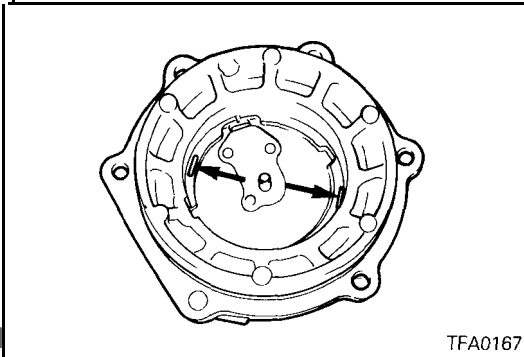

16. Place solder with a length approximately 10 mm (.39 in.) and diameter of 1.6 mm (.06 in.) on the output bearing retainer at the position shown in the diagram and install the outer race.

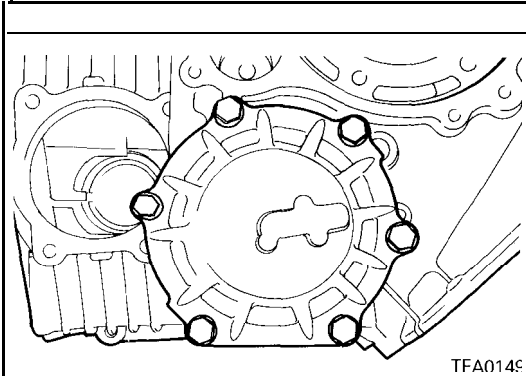

17. Install the output bearing retainer and tighten the bolts to the specified torque.

**Output bearing retainer mounting bolts:
24 Nm (18 ft.lbs.)**

18. Loosen the bolts and remove the output bearing retainer.

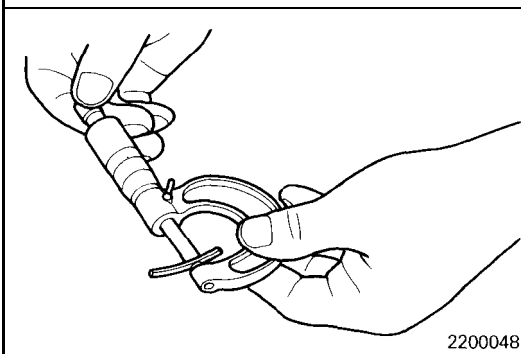

19. Remove the outer race from the output bearing retainer and remove the solder. If the solder is not crushed, repeat steps (4) – (6), using the solder with diameter of 3 mm (.12 in.). Measure the thickness of the crushed solder with a micrometer and select a spacer with a thickness that will provide the standard value for the preload.

Standard value: 0.075 – 0.135 mm (.003 – .0053 in.)

20. Install the spacer selected in the previous item and the outer race on the output bearing retainer.

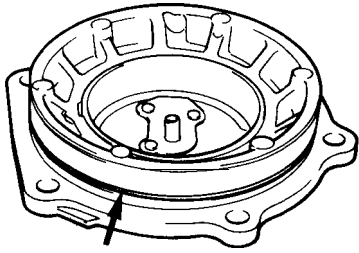

TFA0168

21. Install a new O-ring around the outer circumference of the outer bearing retainer.
22. Coat the O-ring with automatic transmission fluid and tighten the output bearing retainer mounting bolts to the specified torque.

**Output bearing retainer mounting bolts:
24 Nm (18 ft.lbs.)**

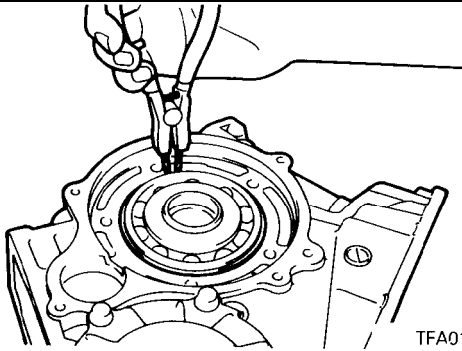

TFA0148

23. Insert the output flange into the case and install a snap ring around the bearing.

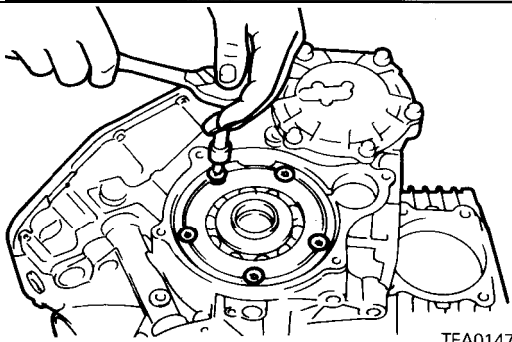

TFA0147

24. Install the bearing retainer using new bolts.
Bearing retainer mounting bolts: 20 Nm (15 ft.lbs.)

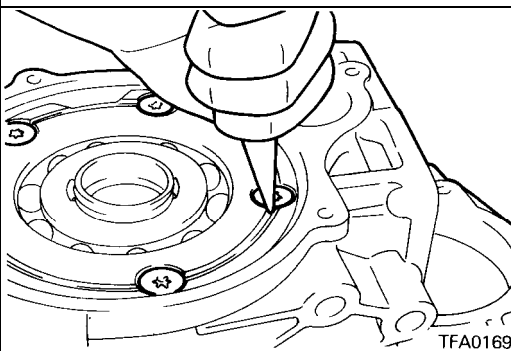

TFA0169

25. Caulk the heads of the bolts.

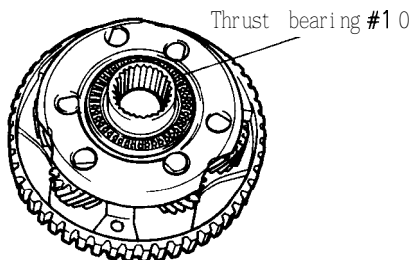

TFA0170

26. Apply a coating of petrolatum to thrust bearing #10 and attach to the planetary carrier.

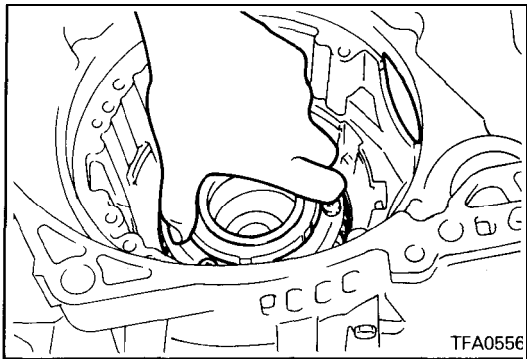

27. Assemble the planetary carrier.

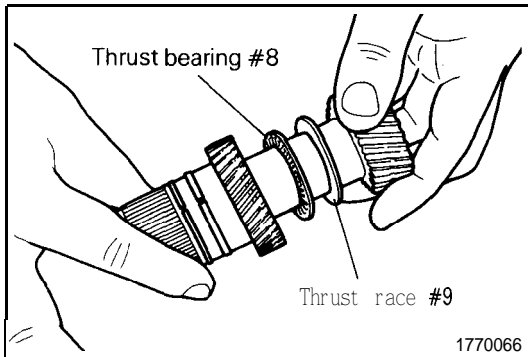

28. Assemble the forward sun gear, thrust race #9, thrust bearing #8 and reverse sun gear.

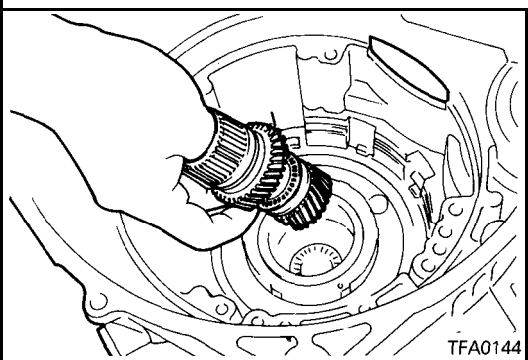

29. Install both sun gears assembled in the previous item into the planetary carrier.

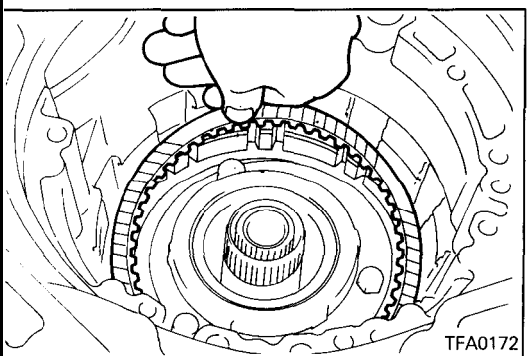

30. Assemble the reaction plate, brake disc and brake plate.

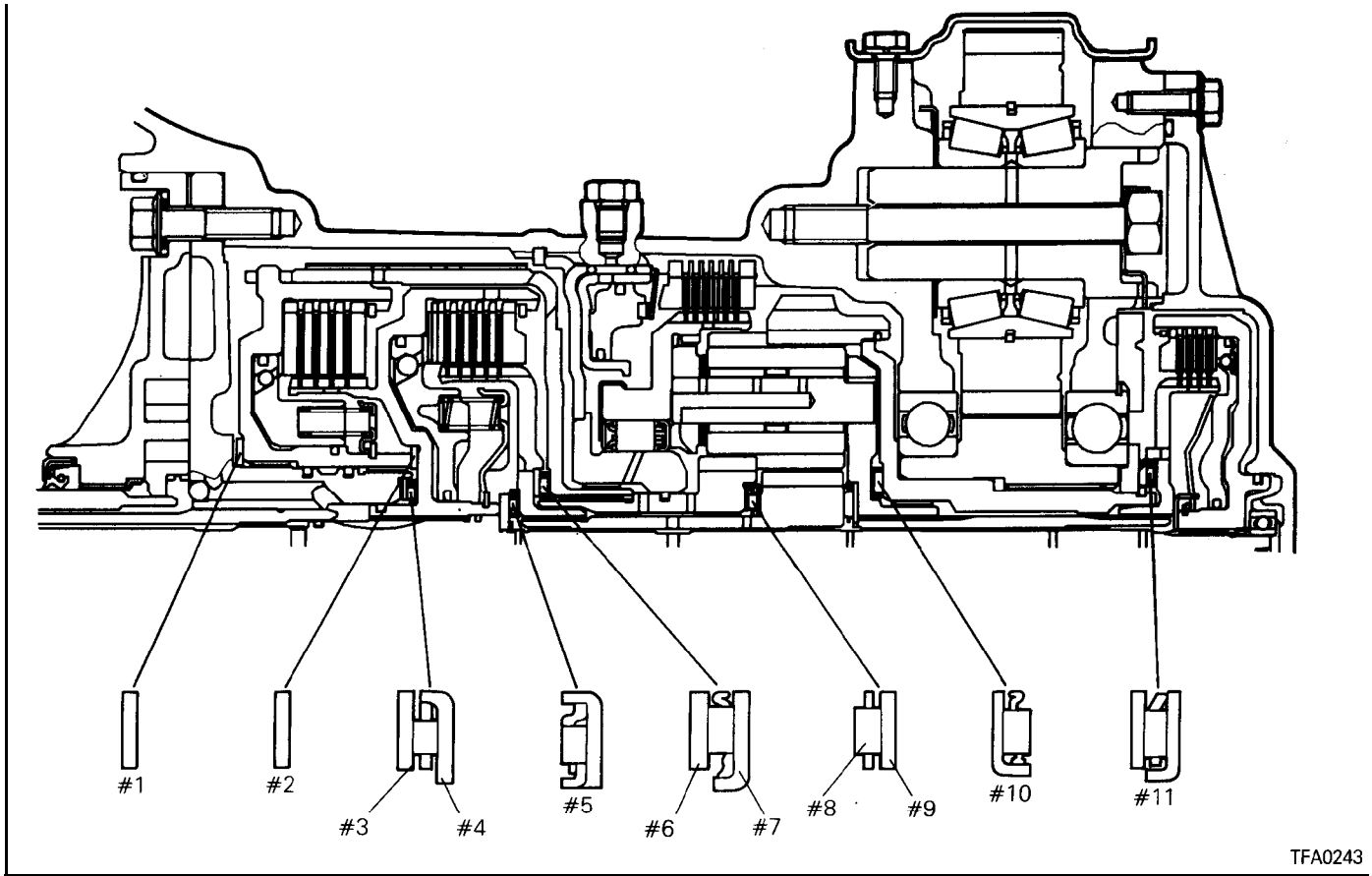

TFA0243

Identification of thrust bearings, thrust races and thrust washers

mm (in.)

Outer diameter	Inner diameter	Thickness	Part No.	Code No.	Outer diameter	Inner diameter	Thickness	Part No.	Code No.
70 (2.7559)	55.7 (2.1929)	1.4 (.0551)	*1	#1	48.1 (1.8937)	34.4 (1.3543)	-	MD707271	#4
70 (2.7559)	55.7 (2.1929)	1.8 (.0709)	*2		42.6 (1.6772)	28 (1.1024)	-	MD720753	#5
70 (2.7559)	55.7 (2.1929)	2.2 (.0866)	*3		54 (2.1260)	38.7 (1.5236)	1.6 (.0630)	MD704936	#6
70 (2.7559)	55.7 (2.1929)	2.6 (.1024)	*4		52 (2.0472)	36.4 (1.4331)	-	MD720010	#7
70 (2.7559)	55.7 (2.1929)	1.8 (.0709)	MD729336 (W4A32) MD731212 (W4A33)	#2	41 (1.6142)	28 (1.1024)	1.2 (.0472)	MD728763 (W4A32)	#8
48.9 (1.9252)	37 (1.4567)	1.0 (.0394)	MD997854 (incl *1)	#3	45 (1.7717)	28 (1.1024)	-	MD735062 (W4A33)	
48.9 (1.9252)	37 (1.4567)	1.2 (.0472)	MD997847 (incl *1)		39 (1.5354)	28 (1.1024)	-	MD728764 (W4A32)	#9
48.9 (1.9252)	37 (1.4567)	1.4 (.0551)	MD997848 (incl *2)		46 (1.8110)	31 (1.2205)	0.8 (.0315)	MD735063 (W4A33)	
48.9 (1.9252)	37 (1.4567)	1.6 (.0630)	MD997849 (incl *2)		52 (2.0472)	36.4 (1.4331)	-	MD720010	#10
48.9 (1.9252)	37 (1.4567)	1.8 (.0709)	MD997850 (incl *3)		58 (2.2835)	44 (1.7323)	-	MD724206	#11
48.9 (1.9252)	37 (1.4567)	2.0 (.0787)	MD997851 (incl *3)						
48.9 (1.9252)	37 (1.4567)	2.2 (.0866)	MD997852 (incl *4)						
48.9 (1.9252)	37 (1.4567)	2.4 (.0945)	MD997853 (incl *4)						

TSB Revision

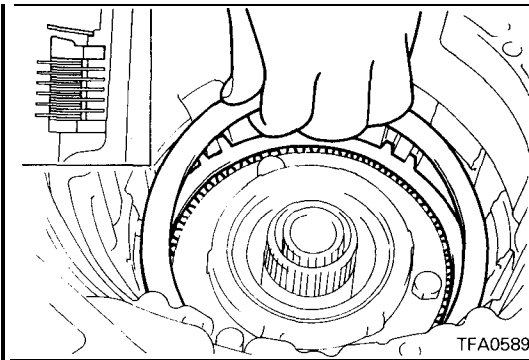

31. Assemble the pressure plate used in disassembly and install the return spring.

Caution

Position the return spring correctly when installing.

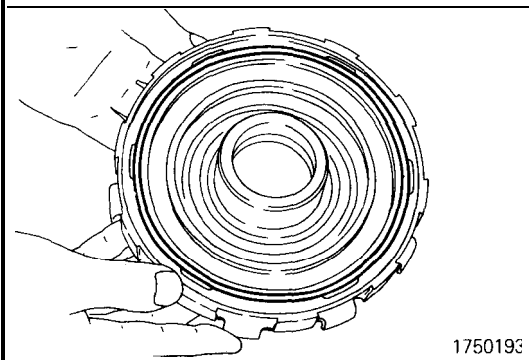

32. Apply a coating of petrolatum jelly to the wave spring and attach it to the center support.

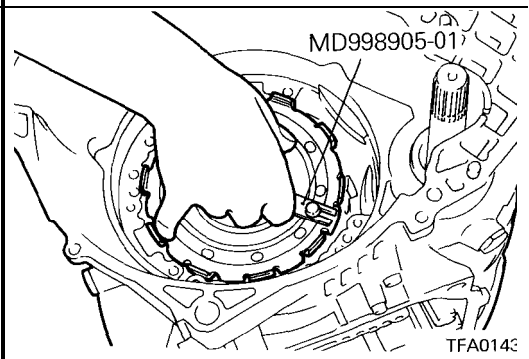

33. Mount the special tool on the center support, install 2 new O-rings and push into the transaxle case.

Caution

1. Coat the O-rings with automatic transmission fluid and align the oil holes.
2. Do not move the wave spring out of position when installing.

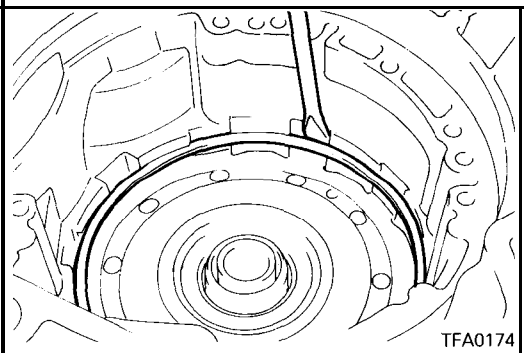

34. Install the snap ring.

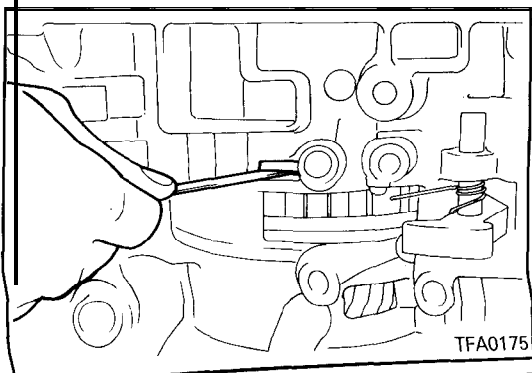

35. Use a thickness gauge and measure the end play of the low/reverse brake. Adjust to the standard value by selecting the proper pressure plate.

Standard value: 1.0 – 1.2 mm (.039 – .047 in.)

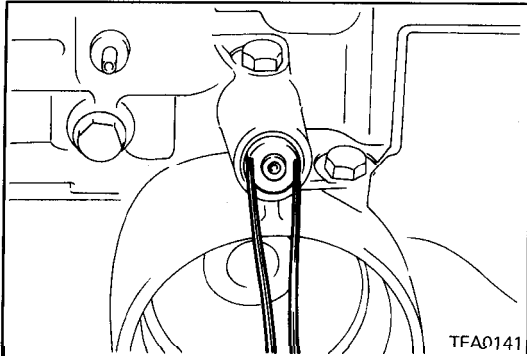

36. Install the air exhaust plug, and then install the plug.
Air exhaust plug: 33 Nm (24 ft.lbs.)

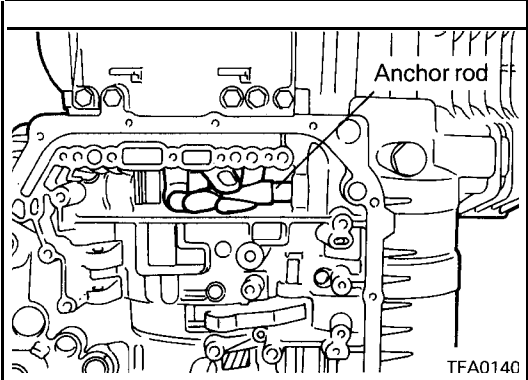

37. Install the anchor rod.

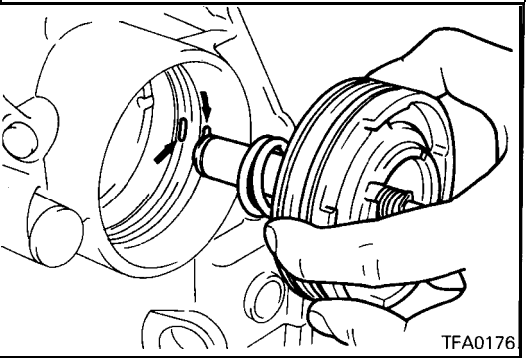

38. Install the kickdown servo spring, piston and sleeve.

Caution

The seal ring alignment hole of the kickdown servo piston must not overlap the oil filler port (indicated by the arrow in the diagram).

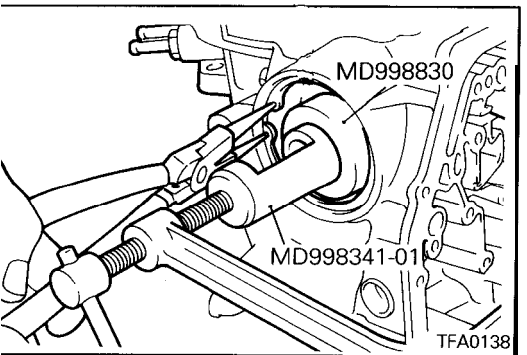

39. Use the special tool to push in the kickdown servo piston and sleeve, and then install a snap ring.

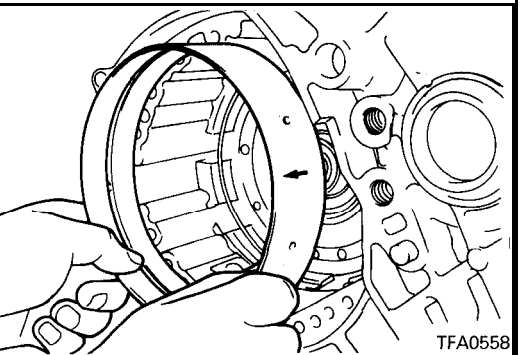

40. Install the kickdown band.

Caution

Install so the arrow mark is facing toward the front.

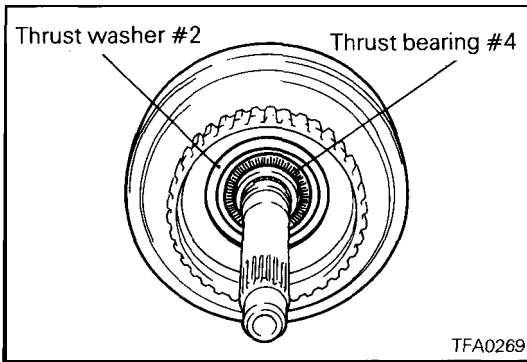

41. Install thrust bearing #4 and thrust washer #2 on the rear clutch.

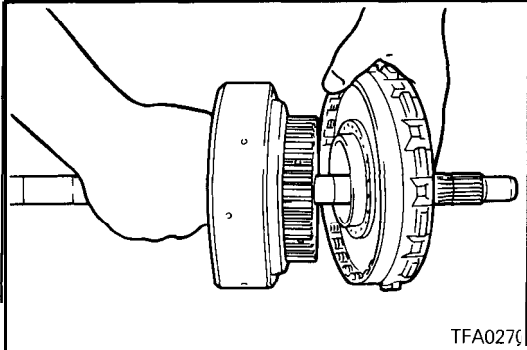

42. Combine the rear clutch assembly and the front clutch assembly.

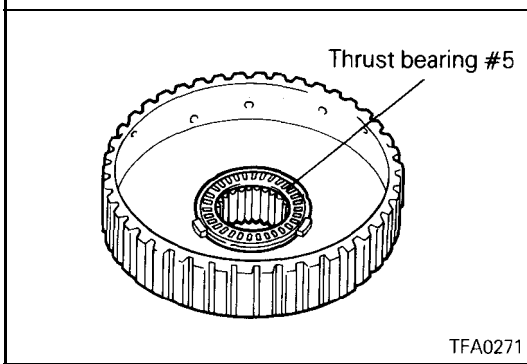

43. Install thrust bearing #5 on the rear clutch hub.

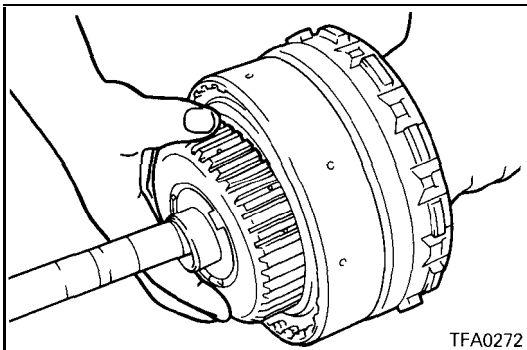

44. Install the rear clutch hub on the rear clutch.

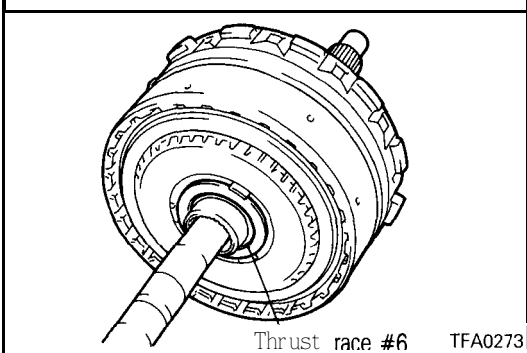

45. Install thrust race #6 on the end of the rear clutch hub.

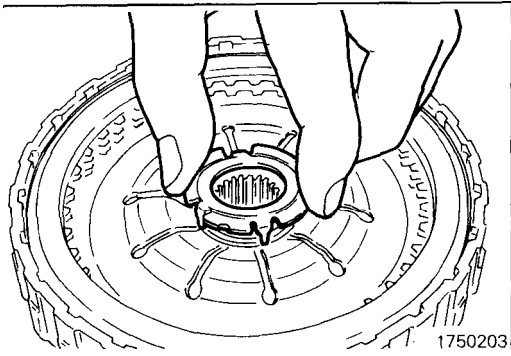

56. Fit the thrust washer on the return spring of the end clutch.

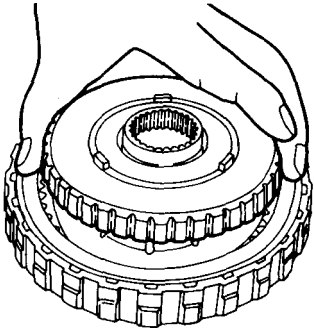

57. Install the end clutch hub on the end clutch assembly.

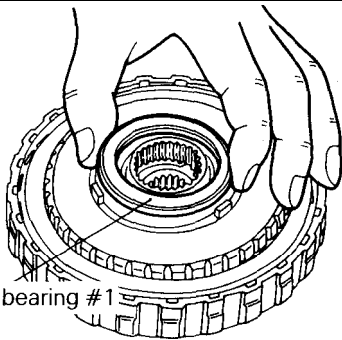

58. Adhere thrust bearing #1 to the end of the clutch hub with petrolatum.

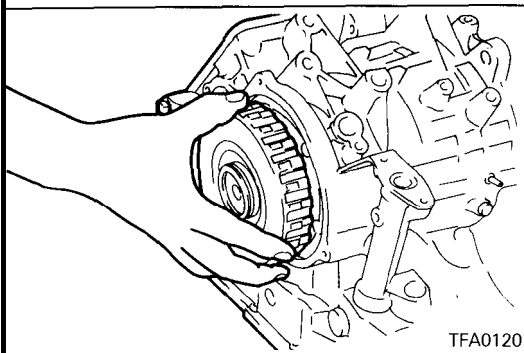

59. Install end clutch assembly.

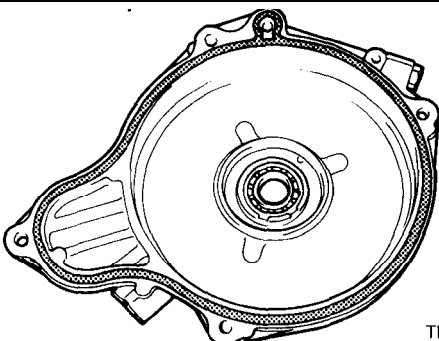

60. Attach a new O-ring to the end clutch cover.

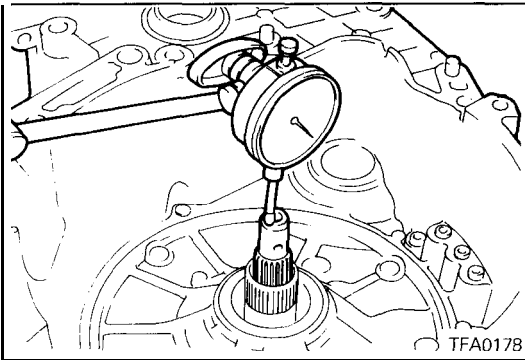

51. Measure the end play of the input shaft. If not the standard value, replace thrust race #3 and thrust washer #1 and adjust to the standard value.

Standard value: 0.3 – 1.0 mm (.012 – .039 in.)

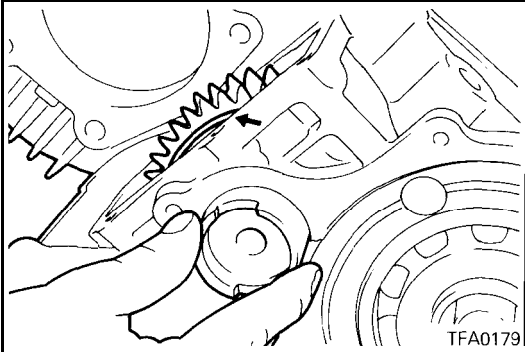

52. Install the spacer, idler gear and bearing and then insert the idler shaft.

Caution

Assemble so that the identification groove on the idler gear faces the rear.

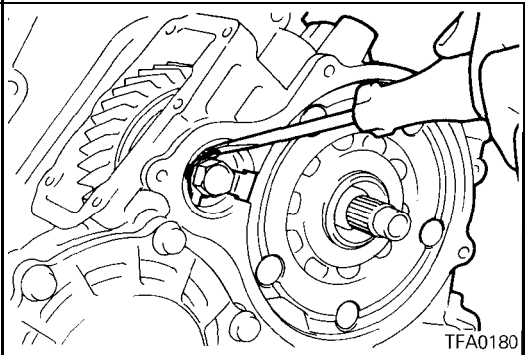

53. Tighten the idler shaft lock bolt together with the new lock plat to the specified torque. Bend the three fingers of the lock plate to prevent turning.

Idler shaft lock bolt: 38 Nm (28 ft.lbs.)

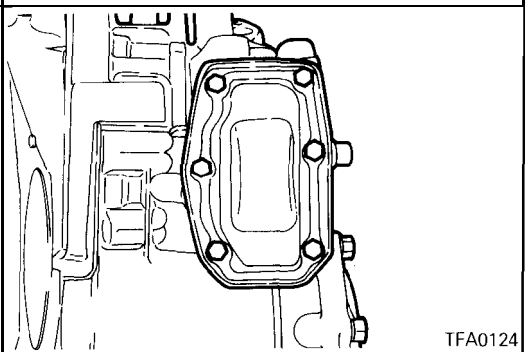

54. Install the idler gear cover and a new gasket.

Idler gear cover mounting bolt: 11 Nm (8 ft.lbs.)

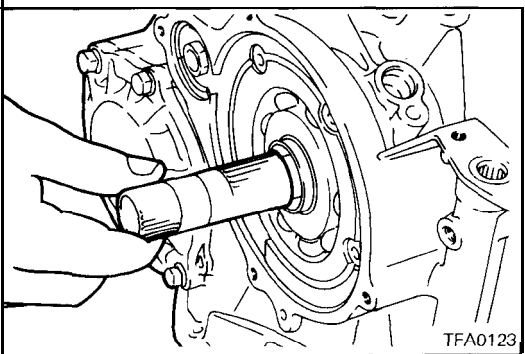

55. Insert the end clutch shaft from the end with the long spline.

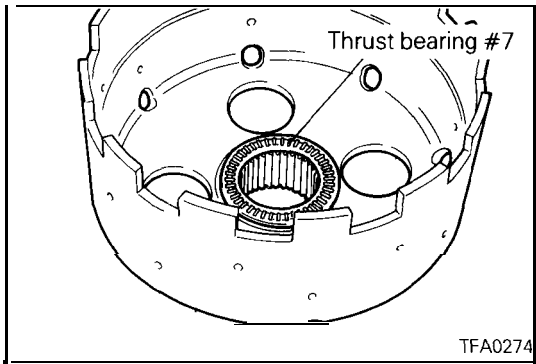

46. Install thrust bearing #7 in the kickdown drum.

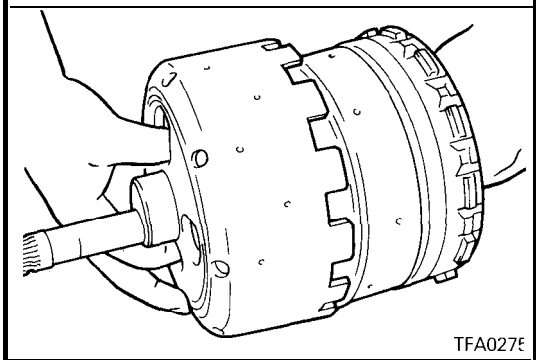

47. Install the clutch assembly in the kickdown drum.

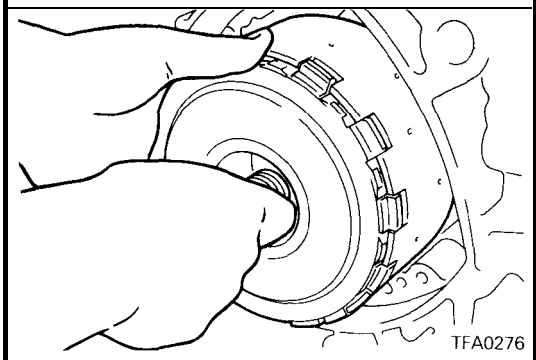

48. Install the clutch assembly and kickdown drum into the transaxle case at the same time.

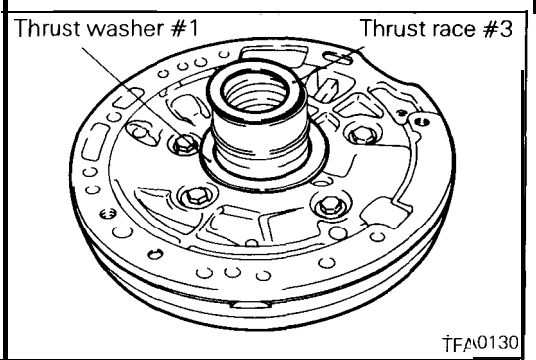

49. Adhere thrust race #3 and thrust washer #1 to the back of the oil pump with petrolatum.

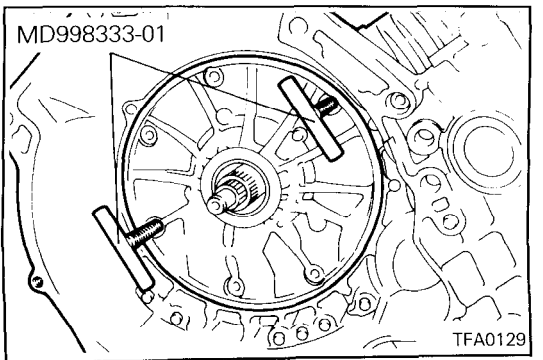

50. Use the special tool to install a new oil pump gasket and oil pump assembly.

Oil pump assembly mounting bolts: 21 Nm (16 ft.lbs.)

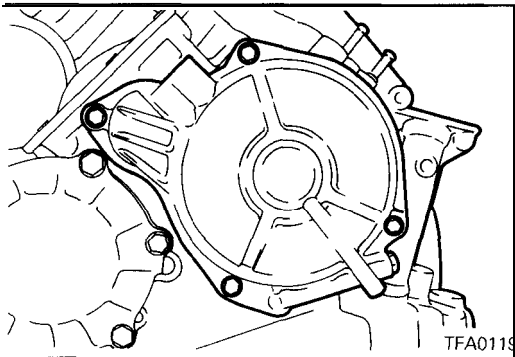

61. Install the end clutch cover and tighten the bolts to the specified torque.

End clutch cover mounting bolts: 11 Nm (8 ft.lbs.)

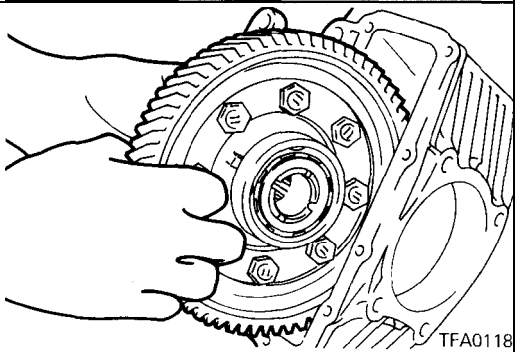

62. Install the differential assembly.

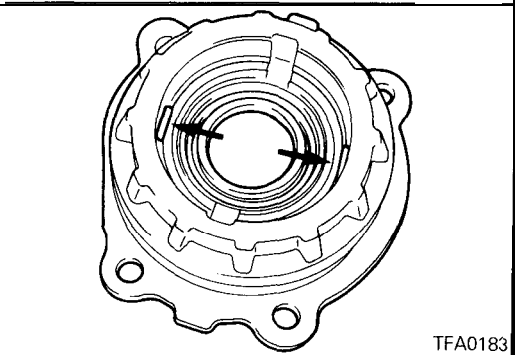

63. Place solder with a length of approximately 10 mm (.39 in.) and diameter of 1.6 mm (.06 in.) on the differential rear bearing retainer at the position shown in the diagram and install the outer race.

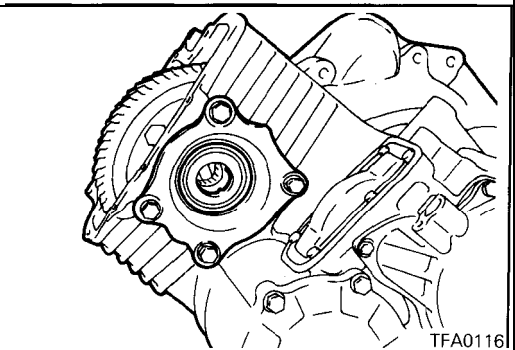

64. Install the differential rear bearing retainer and tighten the bolts to the specified torque.

65. Loosen the bolts, remove the differential rear bearing retainer and remove the solder. If the solder is not crushed, repeat steps (51) – (53). using the solder with the diameter of 3 mm.

**Differential rear bearing retainer mounting bolts:
35 Nm (26 ft.lbs.)**

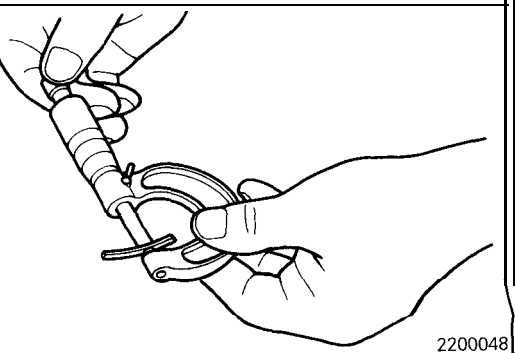

66. Measure the thickness of the crushed solder with a micrometer and adjust by selecting a spacer with a thickness that will provide the standard value for the end play and preload.

Standard value: 0.075 – 0.135 mm (.003 – .0053 in.)

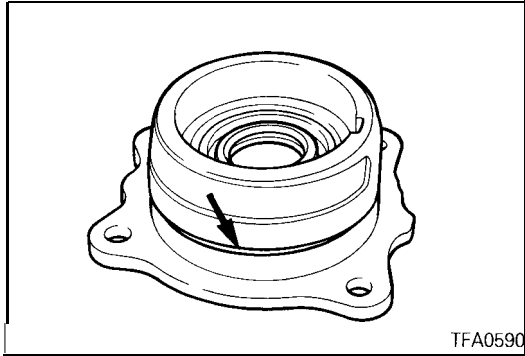

67. Install a new O-ring on the differential rear bearing retainer, coat the O-ring with automatic transmission fluid; then install in the transaxle case and tighten the mounting bolts to the specified torque.

Differential rear bearing retainer mounting bolts:
 35 Nm (26 ft.lbs.)

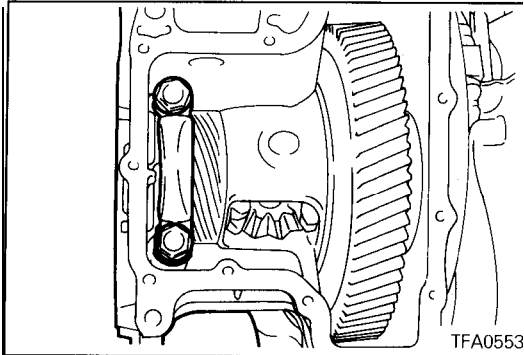

68. Install the front bearing cap and tighten the bolts to the specified torque.

Differential front bearing cap mounting bolts:
 70 Nm (51 ft.lbs.)

69. Install the differential cover and a new gasket.

Differential cover mounting bolts: 11 Nm (8 ft.lbs.)

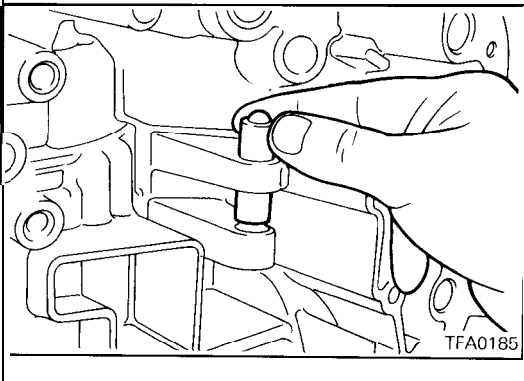

70. Install the detent assembly.

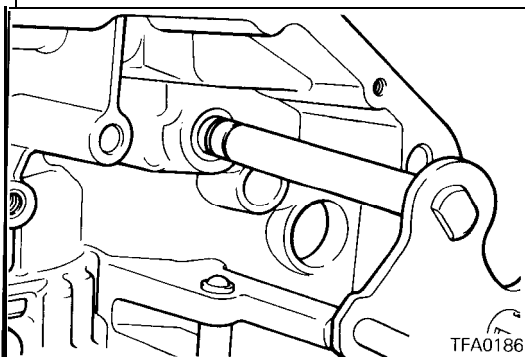

71. Install a new O-ring on the manual control shaft assembly, coat the O-ring with automatic transmission fluid and then insert into the transaxle case.

72. Align the groove in the manual control shaft and the set screw hole; then install the set screw.

Manual **control** shaft set screw: 9 Nm (7 ft.lbs.)

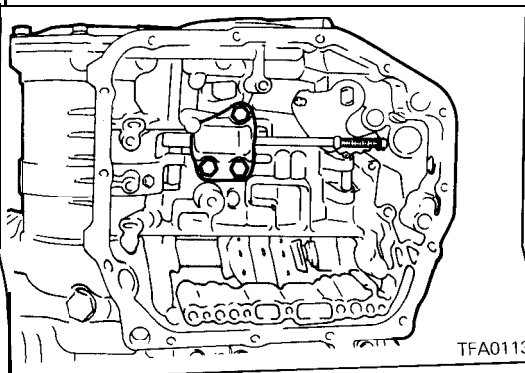

73. Install the parking roller support.

Parking roller support mounting bolts:
 24 Nm (18 ft.lbs.)

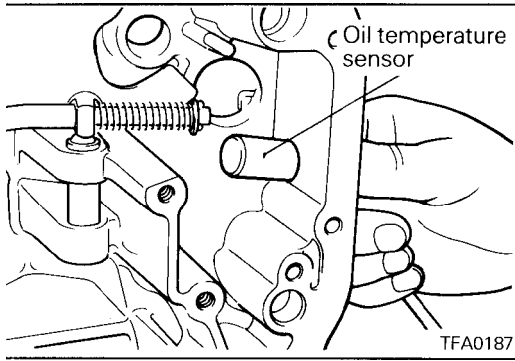

74. Insert the oil temperature sensor into the case.

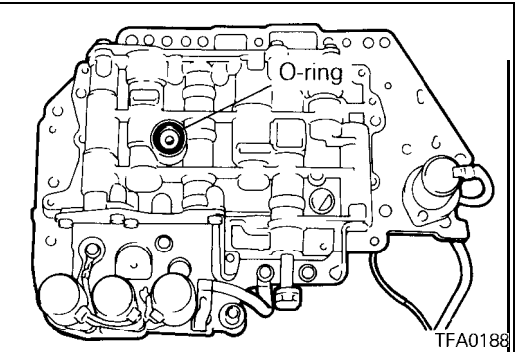

75. Install an O-ring in the O-ring groove at the top of the valve body assembly.

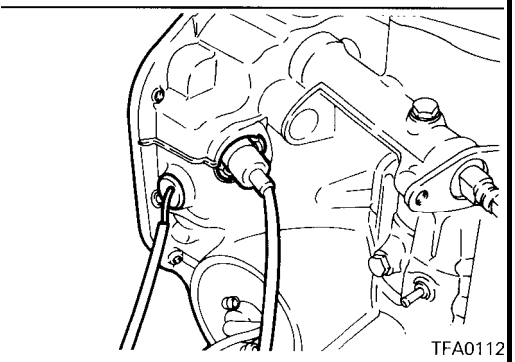

76. Replace the solenoid valve harness grommet O-ring with a new one.

77. Pass the solenoid valve connector through the transaxle case hole from the inside.

78. Push the solenoid valve harness grommet into the case hole.

MODEL 1992

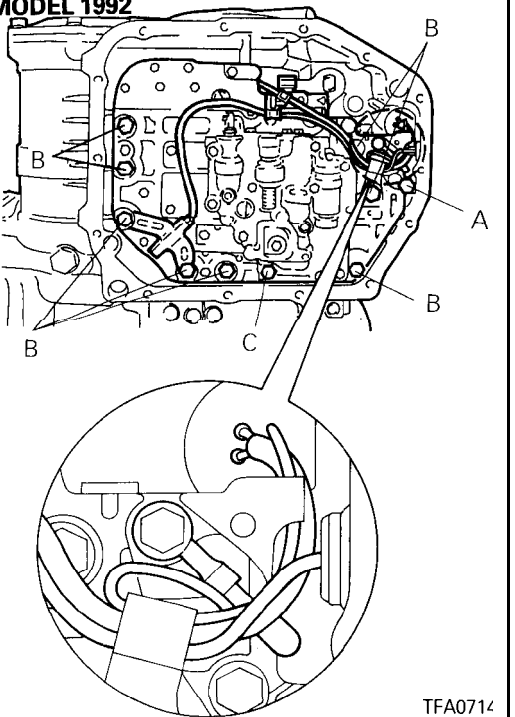

79. Insert the knock pin of the valve body into the case, keeping the detent plate pin in the manual valve groove. Temporarily install the valve body, install the oil temperature sensor and holder; then tighten the mounting bolts to the specified torque.

A bolt: 18 mm (.709 in.)

B bolt: 25 mm (.984 in.)

C bolt: 40 mm (1.575 in.)

Valve body assembly mounting bolts: 11 Nm (8 ft.lbs.)

Caution

Firmly fasten the solenoid valve and oil temperature sensor harness at the position shown in the diagram. Especially, be sure to route the pressure control solenoid valve (PCSV) harness, which is separated from other harness, as shown in the diagram and fasten the harness with a clamp. Failure to fasten it may result in contact with the detent plate or parking rod.

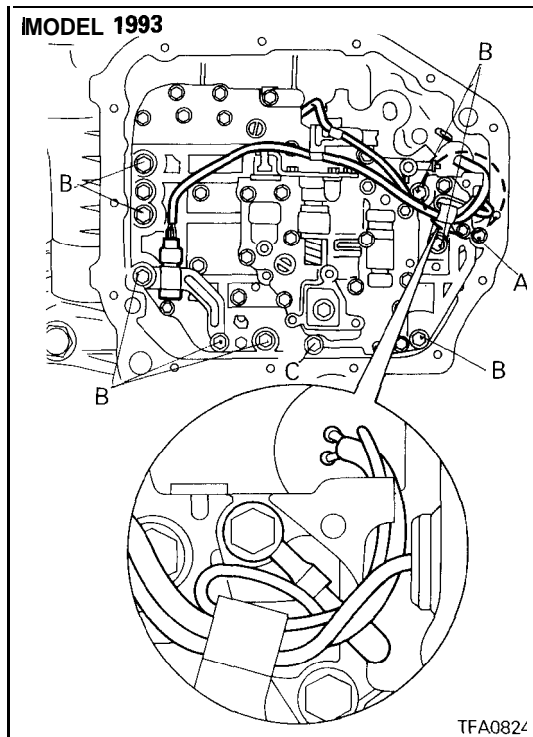

80. Install the oil screen.

Oil filter mounting bolts: 6 Nm (5 ft.lbs.)

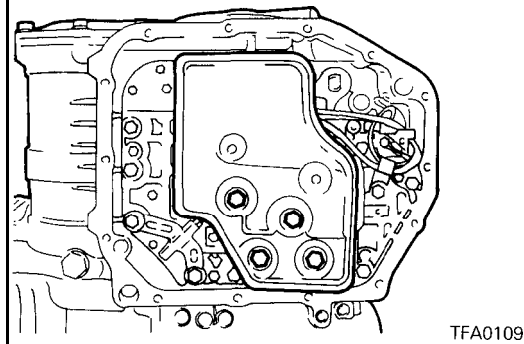

81. Install the magnets in the oil pan and install the oil pan.

Oil pan mounting bolts: 11 Nm (8 ft.lbs.)

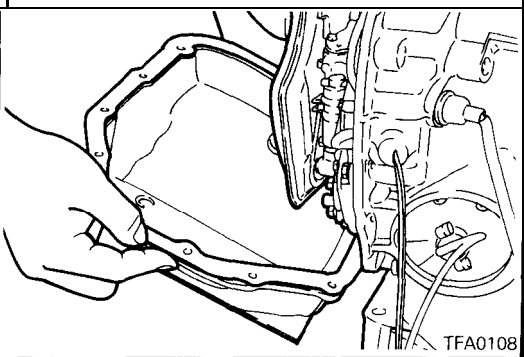

MODEL 1992

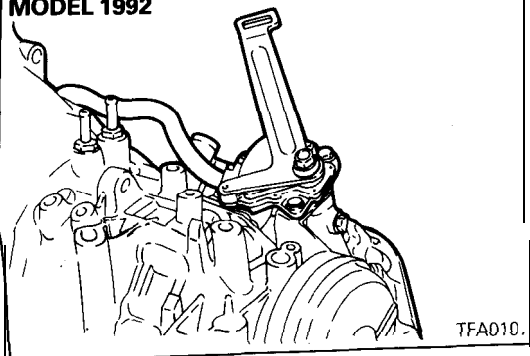

82. Install park/neutral position switch (PNP switch) and manual control lever.

**Park/neutral position switch mounting bolts:
11 Nm (8 ft.lbs.)**

**Manual control lever mounting bolt:
19 Nm (14 ft.lbs.)**

83. Install the speedometer gear assembly.

**Speedometer gear locking plate mounting bolt:
5 Nm (4 ft.lbs.)**

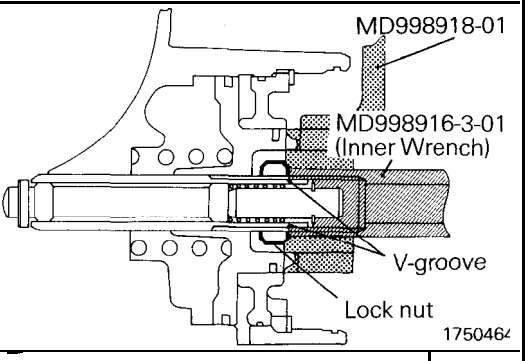
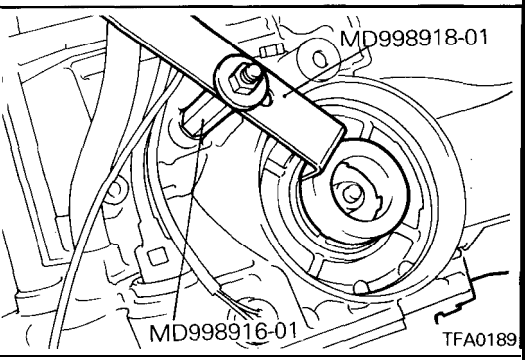
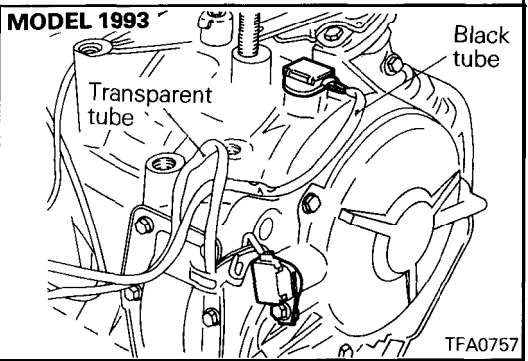
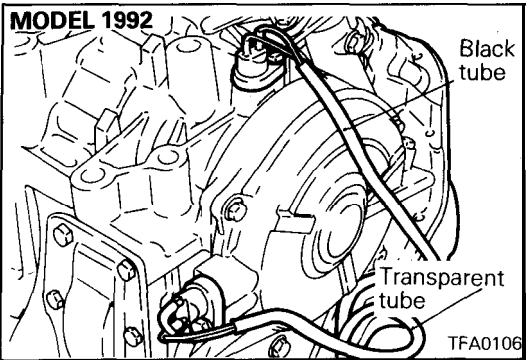
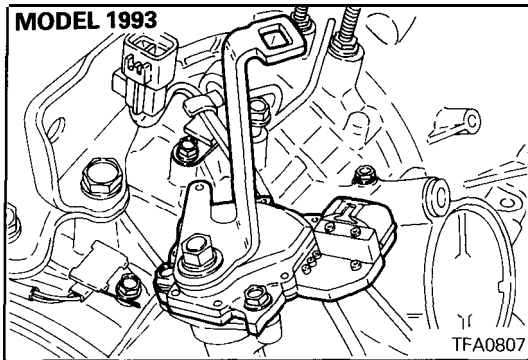

84. Install the pulse generator A and B.

Pulse generator mounting bolts: 11 Nm (8 ft.lbs.)

Caution

Install the black tube on the output gear side and the transparent tube on the end clutch side.

85. Install the oil filler tube and insert the level gauge.

Oil filler tube mounting bolt: 24 Nm (18 ft.lbs.)

86. Install the brackets.

Transaxle mounting bracket bolts: 70 Nm (51 ft.lbs.)

87. Adjust the kickdown servo.

88. Adjust the kickdown servo by the following procedure:

- (a) Fit the claw of the special tool in the notch of the piston to prevent the piston from turning, and use adapter to secure it as illustrated at left.

Caution

1. Do not push in the piston with the special tool.
2. When the adapter is installed to the transaxle case, do not apply excessive torque but tighten with a hand.

- (b) Loosen the lock nut until it is about to reach the V groove in the adjusting rod. Tighten the special tool (inner) until it touches the lock nut.

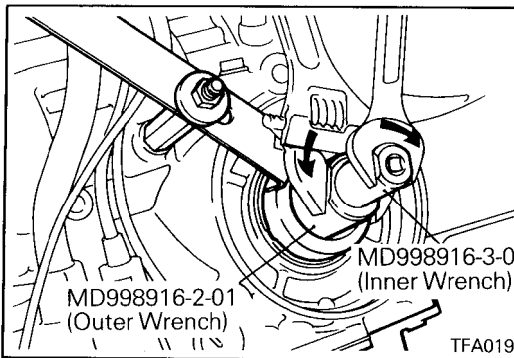

- (c) Fit the special tool (outer) to the lock nut. Turn the outer cylinder counterclockwise and the inner cylinder clockwise to lock the lock nut and the special tool (inner).

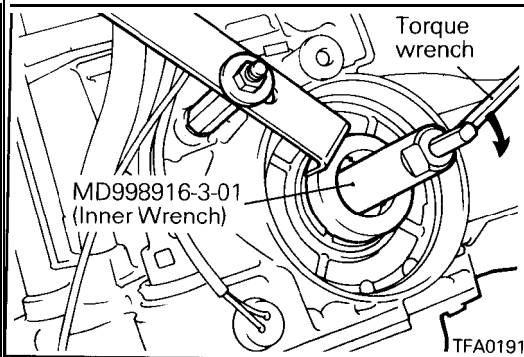

- (d) Fit torque wrench to the special tool (inner) to tighten it to a torque of 10 Nm (7.2 ft.lbs.) and loosen. Repeat this sequence two times before tightening the special tool (inner) to 5 Nm (3.6 ft.lbs.) torque. Then back off the special tool (outer) 2 to 2 1/4 turns.

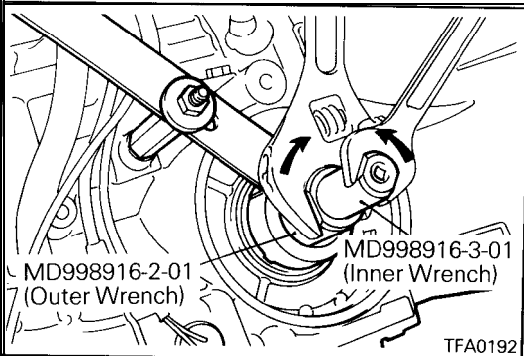

- (e) Fit the special tool (outer) to the lock nut. Turn the outer cylinder clockwise and the inner cylinder counterclockwise to unlock the lock nut and the special tool (inner).

Caution

When unlocking is carried out, apply equal force to both special tools to loosen.

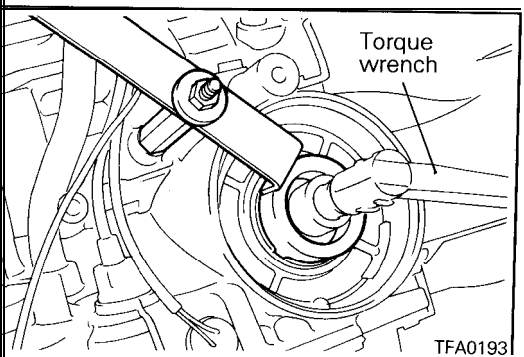

- (f) Tighten the lock nut with a hand until it touches the piston. Then, use torque wrench to tighten the lock nut to specified torque.

Lock nut: 29 Nm (21 ft.lbs.)

Caution

The lock nut may turn with the adjusting rod if tightened quickly with socket wrench or torque wrench.

- (g) Remove the special tool for securing the piston. Install the plug to the Low/Reverse pressure outlet and tighten to specified torque.

89. Install the kickdown servo switch and fasten with a snap ring.

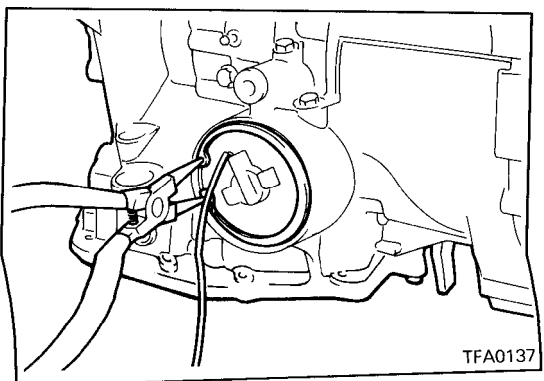

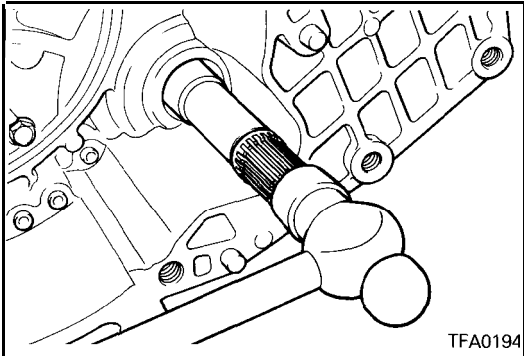

TFA0194

90. Insert the center shaft and hit it with a plastic hammer or similar instrument to install it securely.

NOTE

Apply ATF to the oil seal lip and do not scratch it.

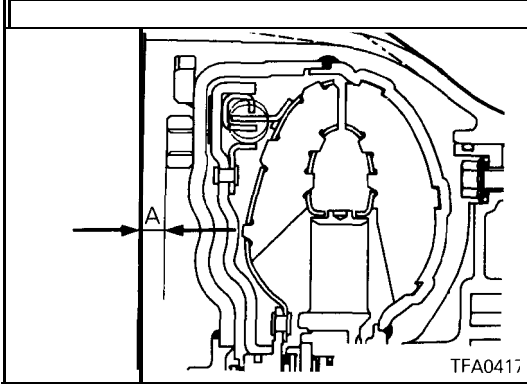

TFA0417

91. Coat the oil pump drive hub with automatic transmission fluid and install the torque converter. Push in firmly so that dimension A in the diagram is the standard value.

Standard value:

W4A33 approx. 16.3 mm (.642 in.)

W4A32 approx. 12.4 mm (.488 in.)

OIL PUMP

DISASSEMBLY AND REASSEMBLY

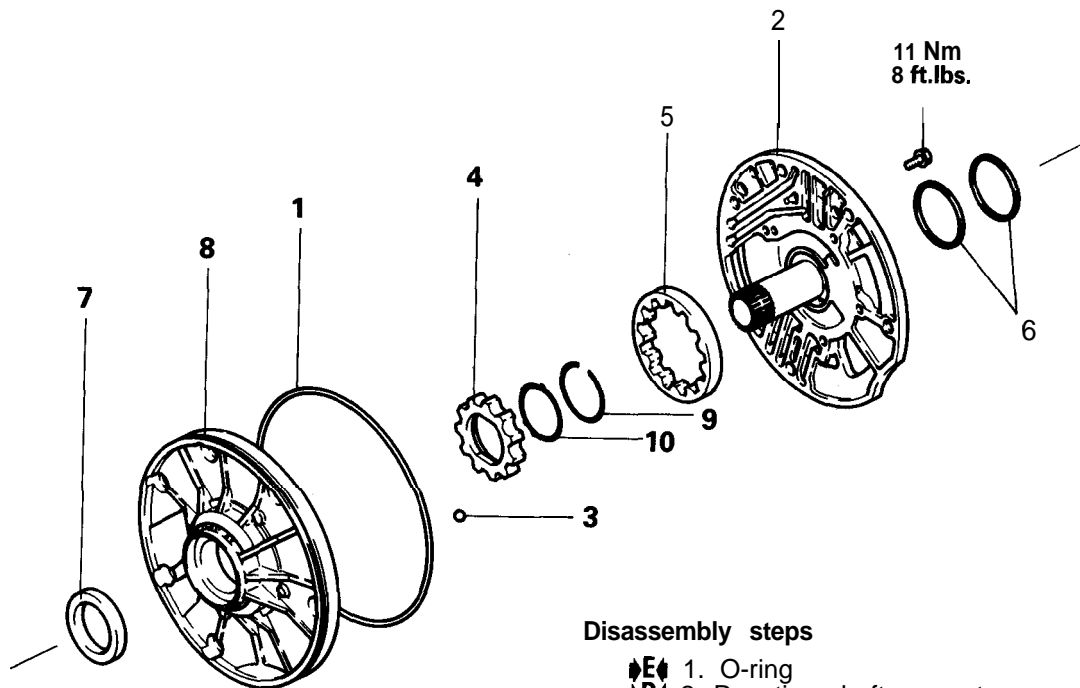

Disassembly steps

- ▶E▶ 1. O-ring
- ▶D▶ 2. Reaction shaft support
- ▶C▶ 3. Steel ball
- ◁A▶▶B▶ 4. Drivegear
- ◁A▶▶B▶ 5. Driven gear
- ▶▶ 6. Seal ring
- ▶A▶ 7. Oil seal
- ▶▶▶ 8. Oil pump housing
- ▶▶▶▶ 9. Snap ring (with torque converter clutch only)
- ▶▶▶▶ 10. Oil seal (with torque converter clutch only)

TFA0245

DISASSEMBLY SERVICE POINT

◁A▶ DRIVE GEAR / DRIVEN GEAR REMOVAL

(1) Make reassembly alignment marks on the drive and driven gears.

REASSEMBLY SERVICE POINTS

▶A▶ OIL SEAL INSTALLATION

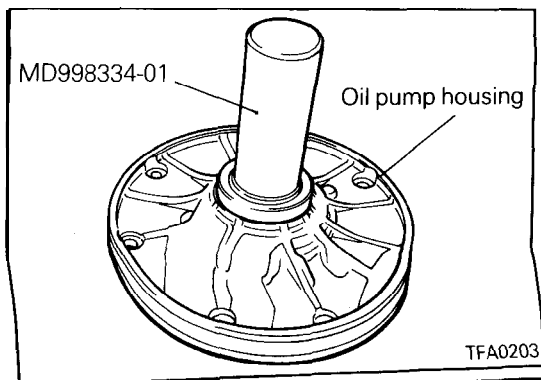

TFA0203

TSB Revision

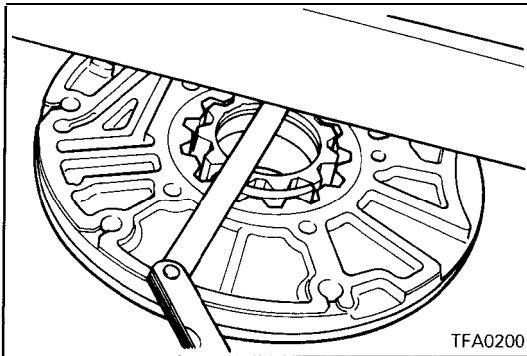

◆B◆ DRIVEN GEAR / DRIVE GEAR SIDE CLEARANCE MEASUREMENT

Standard value: 0.03 – 0.05 mm (.001 – .002 in.)

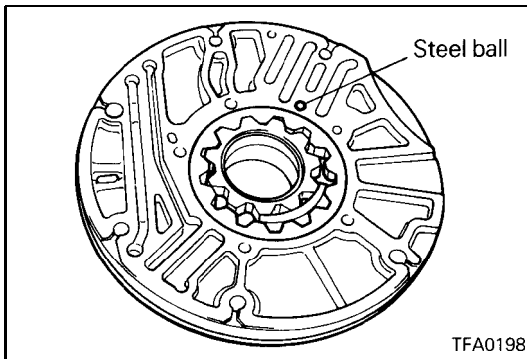

◆C◆ STEEL BALL LOCATION

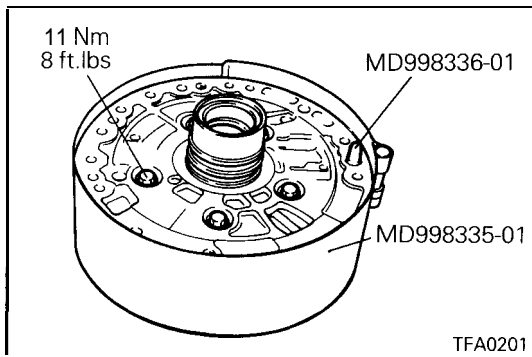

◆D◆ REACTION SHAFT SUPPORT INSTALLATION

- (1) Assemble the reaction shaft support and the pump housing, and tighten the five bolts by fingers.
- (2) Insert the special tool, Guide Pin MD998336-01, in the oil pump bolt hole and tighten the peripheries of the support and housing with the special tool, Band MD998335-01, to locate the support and housing.
- (3) Tighten the five bolts to the specified torque.
- (4) Make sure that the oil pump gear turns freely.

◆E◆ O-RING INSTALLATION

- (1) Install a new O-ring in the groove of the pump housing and apply petrolatum jelly to the O-ring.

FRONT CLUTCH

DISASSEMBLY AND REASSEMBLY – W4A32

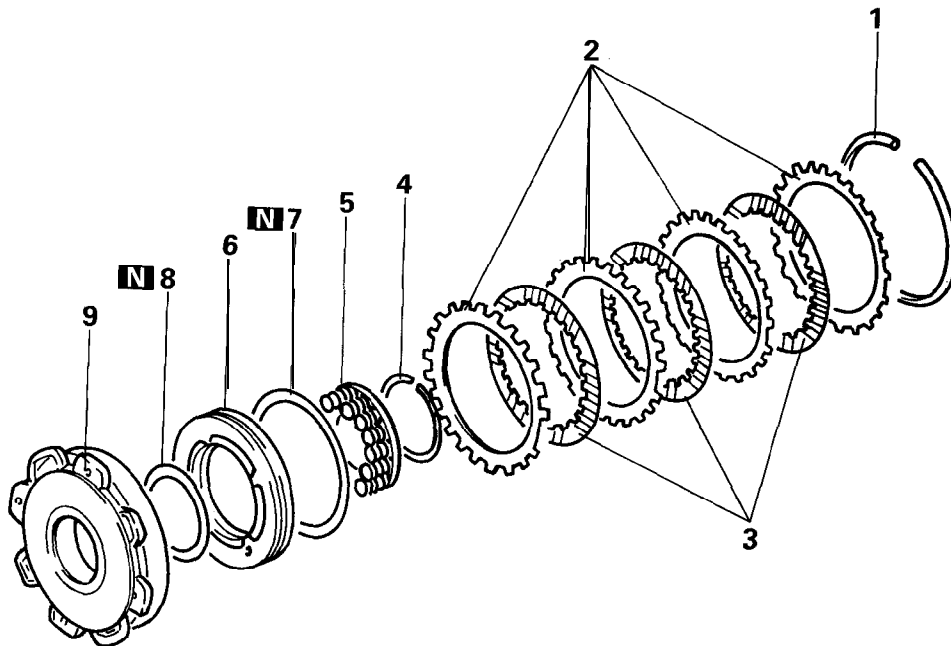

TFA0029

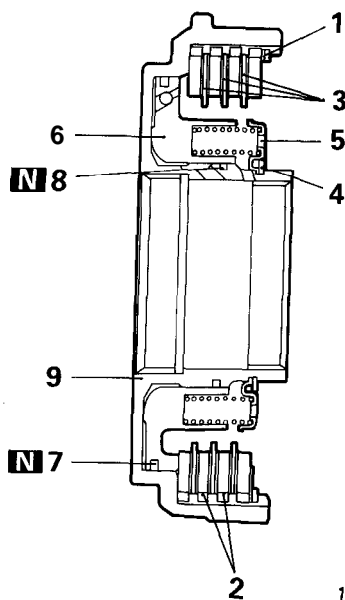

1750213

Disassembly steps

- ◆C◆ 1. Snap ring
- ◆B◆ 2. Clutch reaction plate
- 3. Clutch disc
- ◁A◆ ◆A◆ 4. Snap ring
- 5. Return spring
- 6. Front clutch piston
- 7. D-ring
- 8. D-ring
- 9. Front clutch retainer

1750213

DISASSEMBLY AND REASSEMBLY – F4A33, W4A33

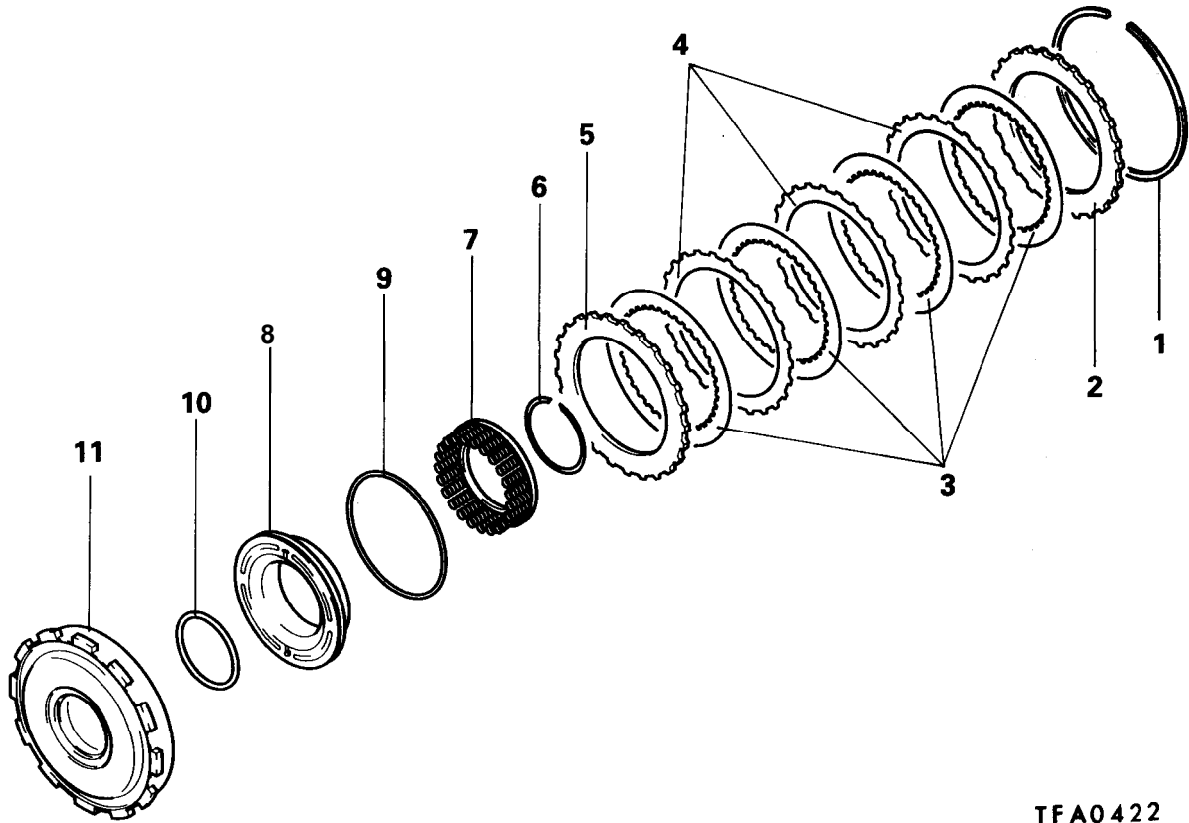

TFA0422

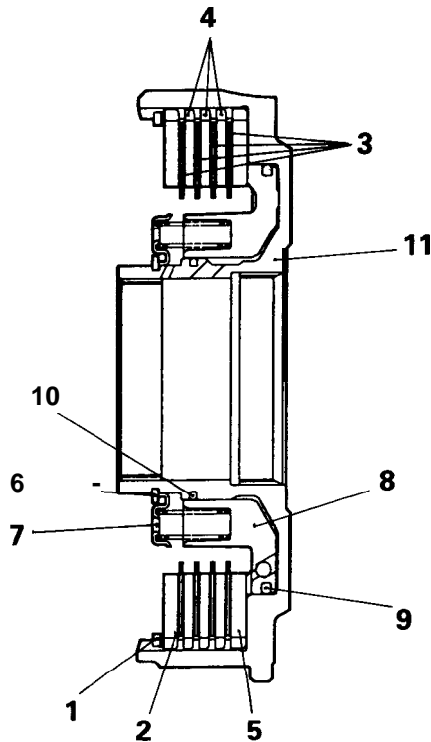

TFA0423

Disassembly steps

- ◆C◆ 1. Snap ring
- ◆B◆ 2. Clutch reaction plate
- 3. Clutch disc
- ◆B◆ 4. Clutch plate
- ◆B◆ 5. Clutch pressure plate
- ◁A▷ ◆A◆ 6. Snap ring
- 7. Return spring
- 8. Front clutch piston
- 9. D-ring
- 10. D-ring
- 11. Front clutch retainer

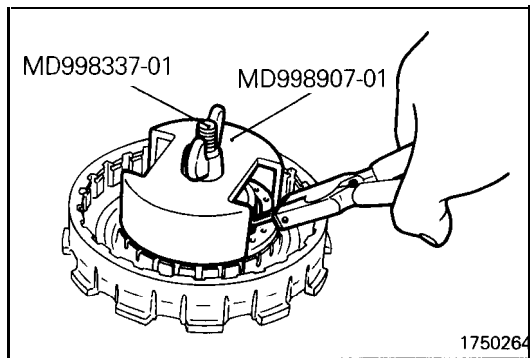

DISASSEMBLY SERVICE POINT

↔A↔ SNAP RING REMOVAL

- (1) Compress the return spring with the special tool.
- (2) Remove the snap ring.

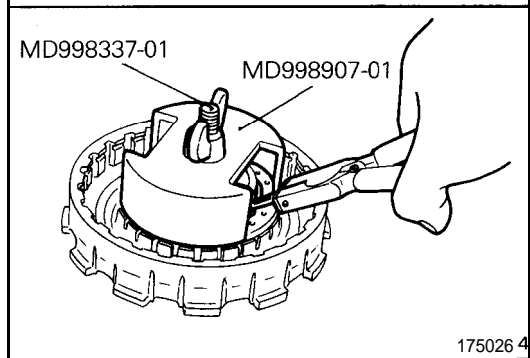

REASSEMBLY SERVICE POINTS

↔A↔ SNAP RING INSTALLATION

- (1) Compress the return spring with the special tool.
- (2) install the snap ring.

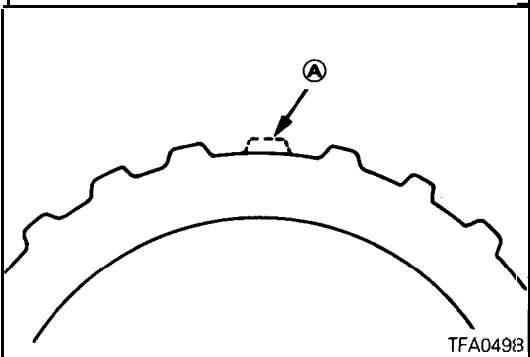

↔B↔ CLUTCH PLATE INSTALLATION

- (1) Install the clutch plate with their missing tooth portions (A in the illustration) in alignment.

NOTE

This design is to facilitate escape of automatic transmission fluid and improve the cooling efficiency of the plate and disc.

- (2) Install the innermost plate with their shear drops directed as shown in the illustration.

W4A32

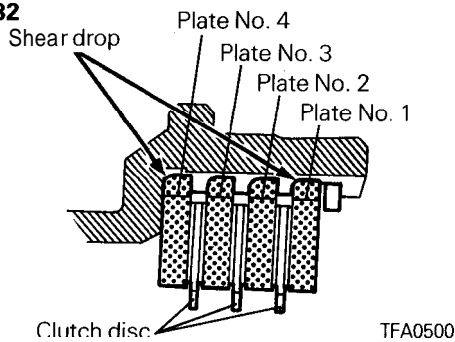

W4A32

Plate No.	Thickness mm (in.)	Identification mark
1	5.0 (.197)	A
2	3.1 (.122)	B
3	3.1 (.122)	B
4	3.7 (.146)	None

F4A33, W4A33

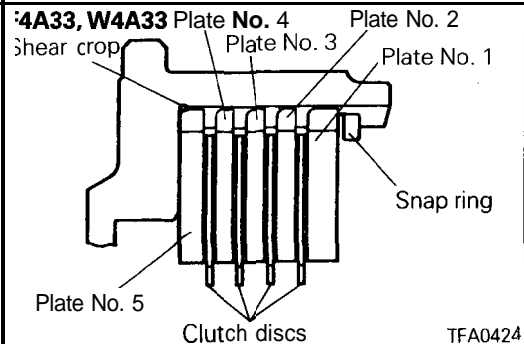

F4A33, W4A33

Plate No.	Thickness mm (in.)
1	5.0 (.197)
2	2.2 (.087)
3	2.2 (.087)
4	2.2 (.087)
5	3.8 (.150)

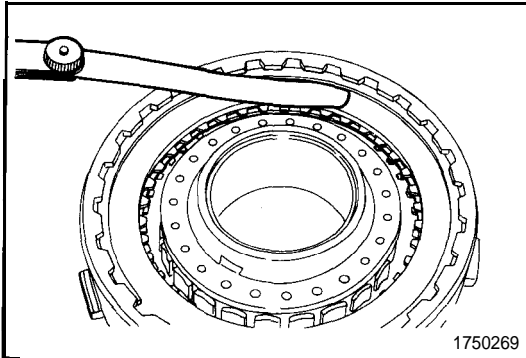
**❖C❖ SNAP RING SELECTION**

- (1) Check clearance between the snap ring and clutch reaction plate. To check the clearance, hold entire circumference of the clutch reaction plate down with 50 N (11 lbs.) force. If clearance is out of standard value, select a snap ring to obtain the standard value.

Standard value:**W4A32** 0.7 – 0.9 mm (.028 – .035 in.)**F4A33, W4A33** 0.8 – 1.0 mm (.031 – .039 in.)**NOTE**

Position the gap of the snap ring approx. 180° away from that of the return spring mounting snap ring.

REAR CLUTCH

DISASSEMBLY AND REASSEMBLY – W4A32

Disassembly steps

1. Seal ring
- ▶E▶ 2. Input shaft
3. O-ring
4. Snap ring
5. Thrust race
6. Seal ring
- ▶D▶ 7. Snap ring
- ▶C▶ 8. Clutch reaction plate
9. Clutch disc
- ▶C▶ 10. Clutch plate
- ▶C▶ 11. Clutch pressure plate
- ◊A▶▶A▶ 12. Wave spring
13. Return spring
14. Rear clutch piston
15. Rear clutch retainer
16. D-ring
17. D-ring

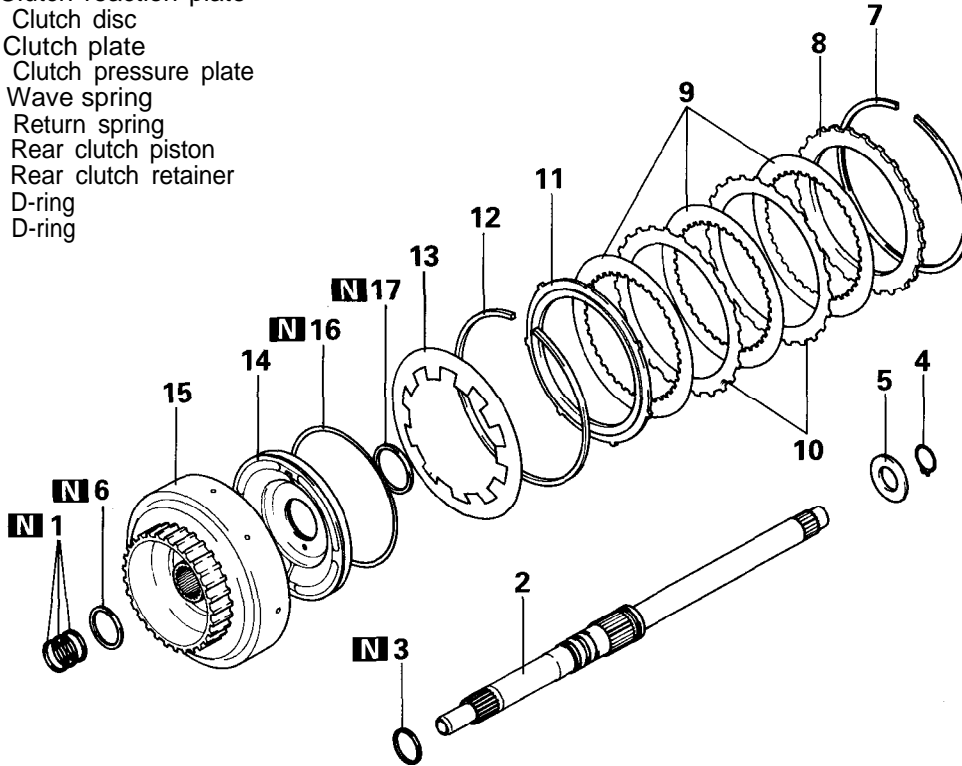

TFAO 621

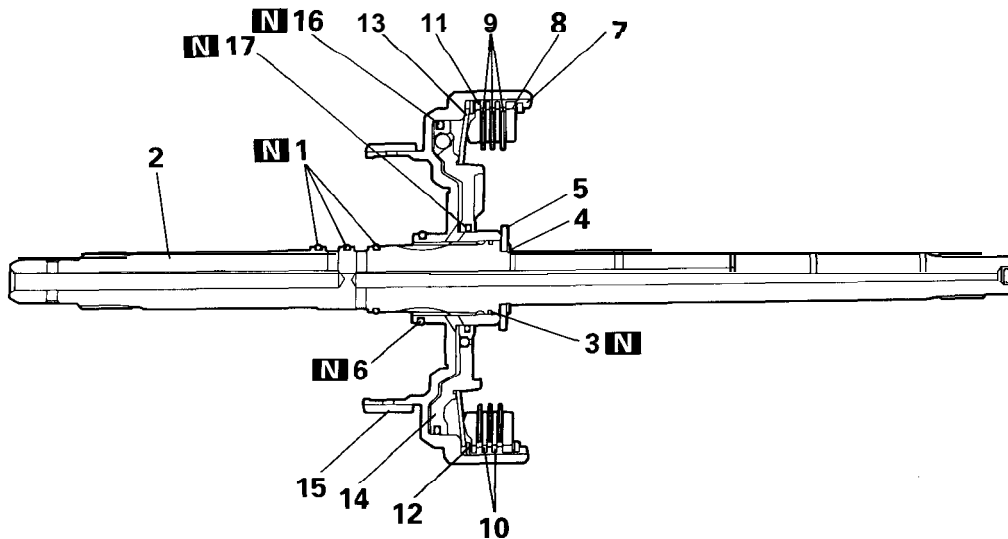

DISASSEMBLY AND REASSEMBLY – F4A33, W4A33

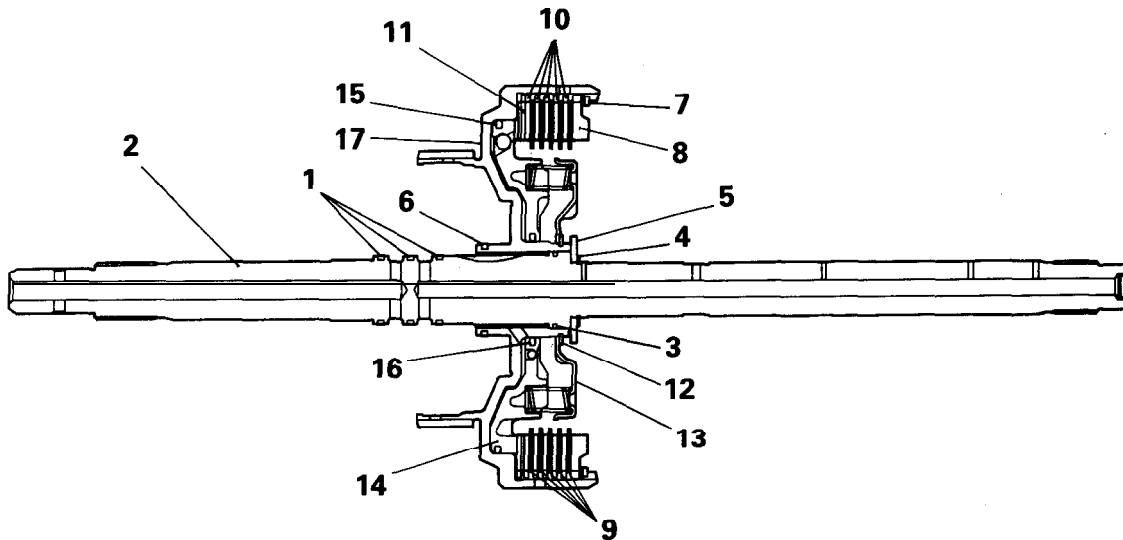
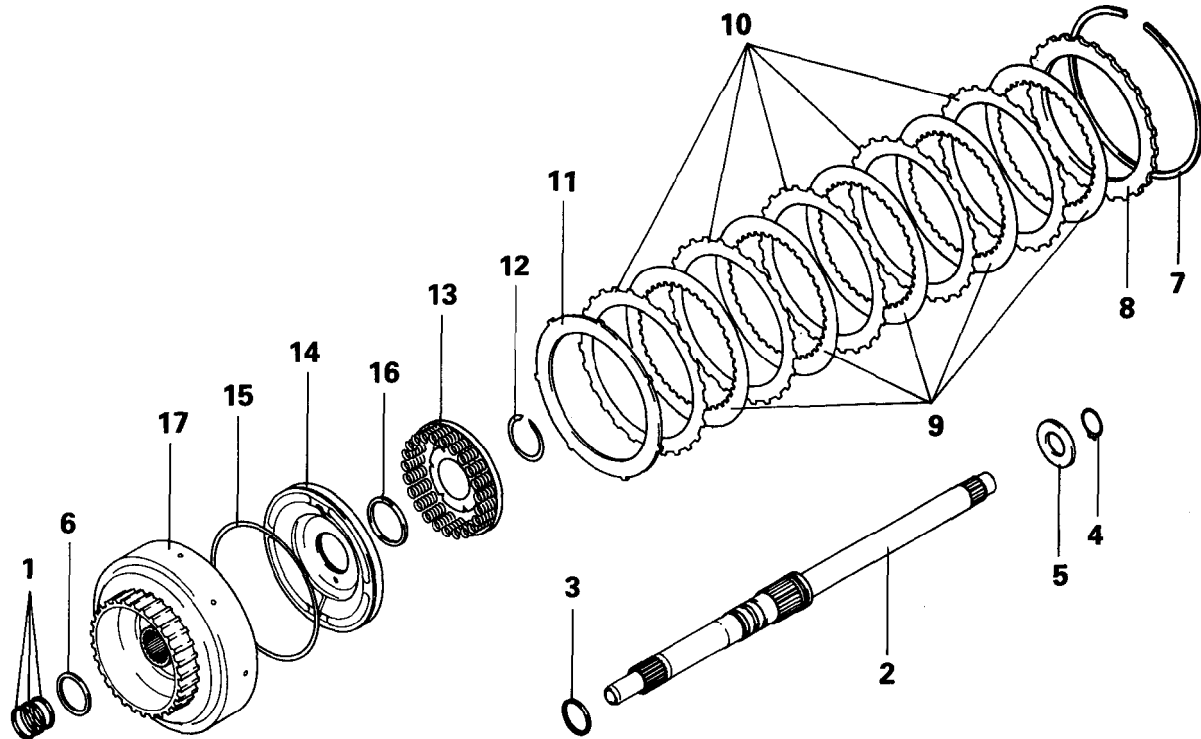

TFA0418

*: The number of seal rings varies with the transaxle model

Models with torque converter clutch	3
Models without torque converter clutch	1

TF A0490

Disassembly steps

- 1. Seal ring*
- ▶E◀ 2. Input shaft
- 3. O-ring
- 4. Snap ring
- 5. Thrust race
- 6. Seal ring
- ▶D▶ 7. Snap ring
- ▶C▶ 8. Clutch reaction plate
- 9. Clutch disc
- ▶C▶ 10. Clutch plate
- 11. Wave spring
- ◀B▶ ▶B▶ 12. Snap ring
- 13. Return spring
- 14. Rear clutch piston
- 15. D-ring
- 16. D-ring
- 17. Rear clutch retainer

TSB Revision

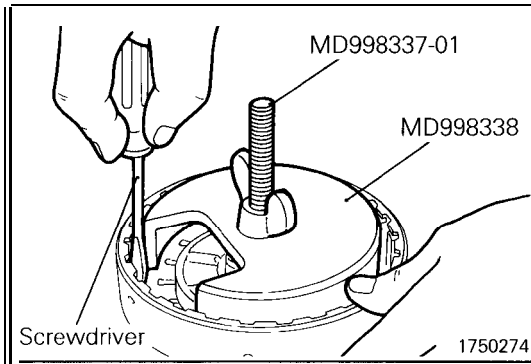
**DISASSEMBLY SERVICE POINTS****◀A▶ WAVE SPRING REMOVAL**

- (1) Compress the return spring with the special tool.
- (2) Using a screwdriver, remove the wave spring.

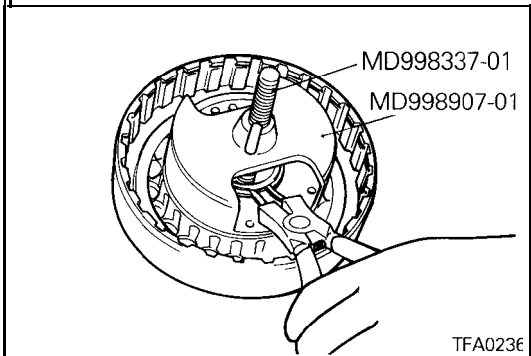
**◀B▶ SNAP RING REMOVAL**

- (1) Compress the return spring with the special tool.
- (2) Using a screwdriver, remove the snap ring.

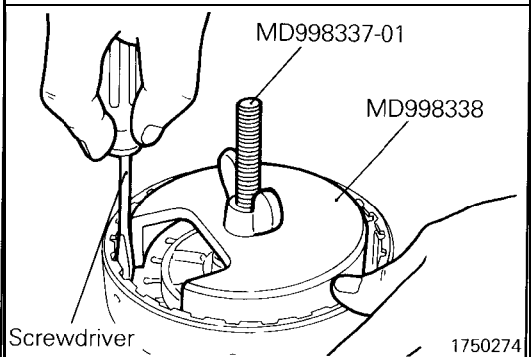
**REASSEMBLY SERVICE POINTS****▶A▶ WAVE SPRING INSTALLATION**

- (1) Compress clutch reaction plate with the special tool.
- (2) Install the wave spring.

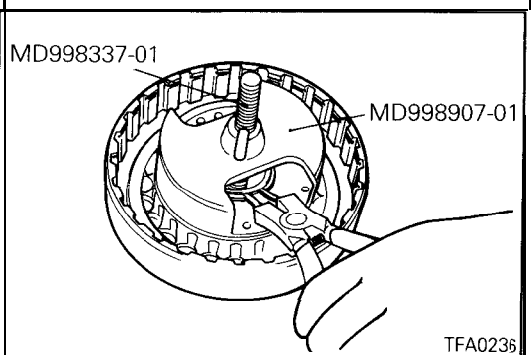
**▶B▶ SNAP RING INSTALLATION**

- (1) Compress clutch reaction plate with the special tool.
- (2) Install the snap ring.

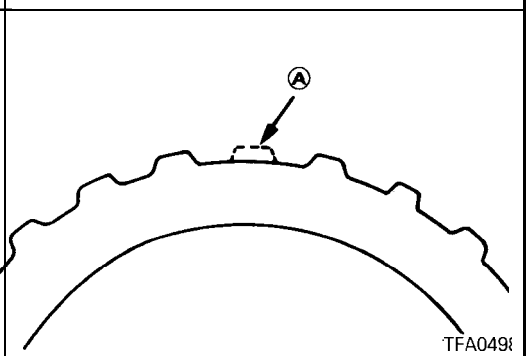
**▶C▶ CLUTCH PRESSURE PLATE / CLUTCH PLATE / CLUTCH REACTION PLATE INSTALLATION**

- (1) Install the clutch pressure plate, clutch plates and clutch reaction plate with their missing tooth portions (A) in alignment.

NOTE

This design is to facilitate escape of automatic transmission fluid and improve the cooling efficiency of the plates and disc.

W4A32

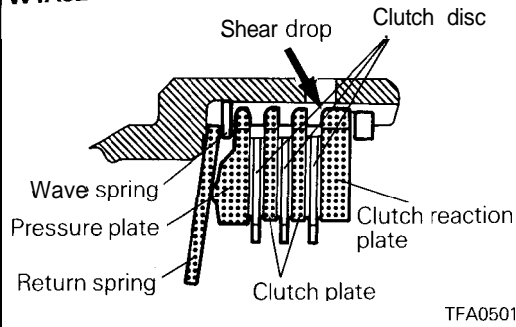

- (2) Install the clutch reaction plate with its shear drop directed as shown in the illustration.

F4A33, W4A33

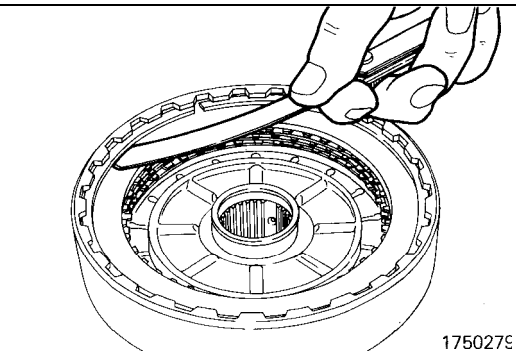
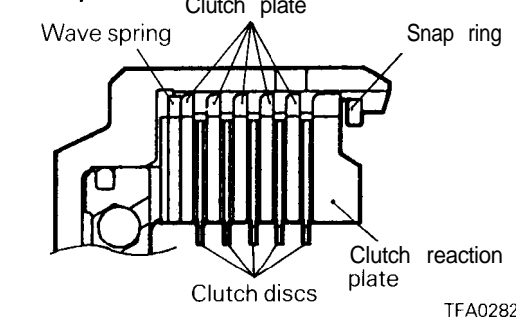

◆D◆ SNAP RING SELECTION

- (1) Check clearance between the snap ring and clutch reaction plate. To check the clearance, hold entire circumference of the clutch reaction plate down with 50 N (11lbs.) force. If clearance is out of standard value, select a snap ring to obtain the standard value.

Standard value:

W4A32 0.4 – 0.6 mm (.016 – .024 in.)

F4A33, W4A33 1.0 – 1.2 mm (.039 – .047 in.)

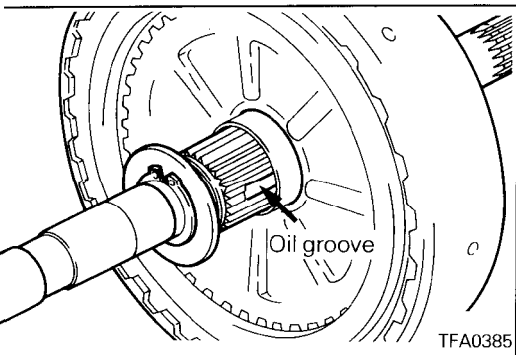

◆E◆ INPUT SHAFT INSTALLATION

- (1) Install the input shaft with its oil groove aligned with the oil hole in the rear clutch retainer.

END CLUTCH

DISASSEMBLY AND REASSEMBLY

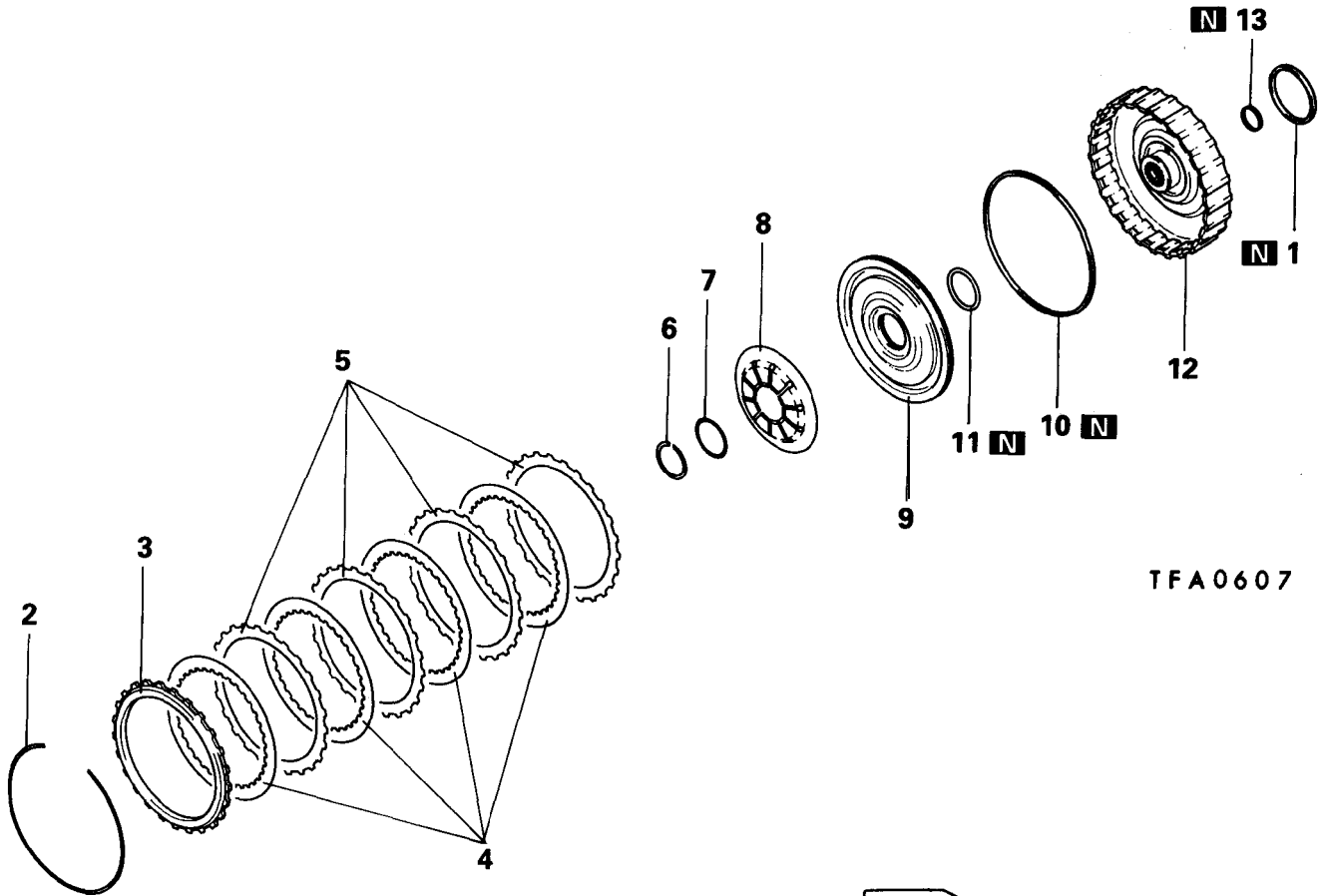

TFA0607

Disassembly steps

- 1. Seal ring
- ▶B◀ 2. Snap ring
- 3. Clutch reaction plate
- 4. Clutch disc
- 5. Clutch plate
- ▶A▶ 6. Snap ring
- 7. Washer
- 8. Return spring
- ◀A▶ 9. End clutch piston
- 10. Oil seal
- 11. D-ring
- 12. End clutch retainer
- 13. Oil seal

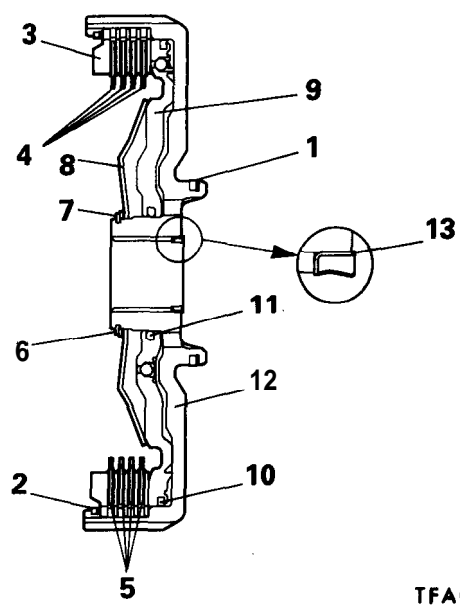

TFA0608

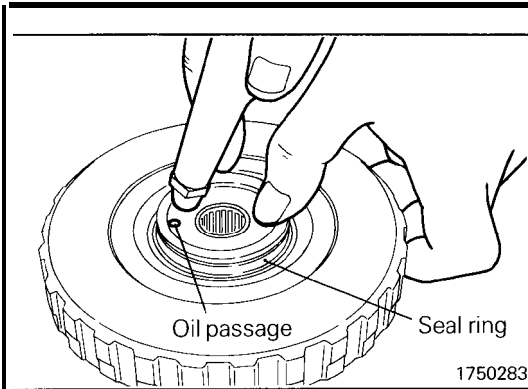
**DISASSEMBLY SERVICE POINT****◆A◆ END CLUTCH PISTON REMOVAL**

- (1) Remove the piston. If it is hard to remove, place the retainer on the workbench with piston side down and blow air through the oil passage in the back of retainer.

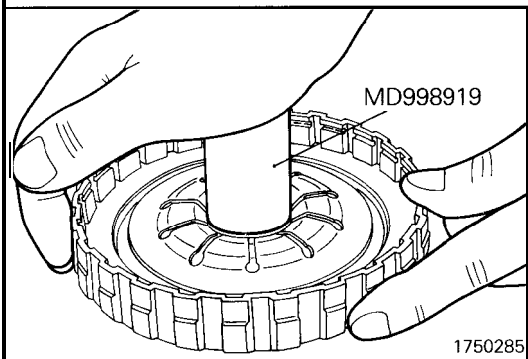
**REASSEMBLY SERVICE POINTS****◆A◆ SNAP RING INSTALLATION**

- (1) Using the special tool, fit the snap ring.

Caution

Make sure that the snap ring is fitted in position in the groove.

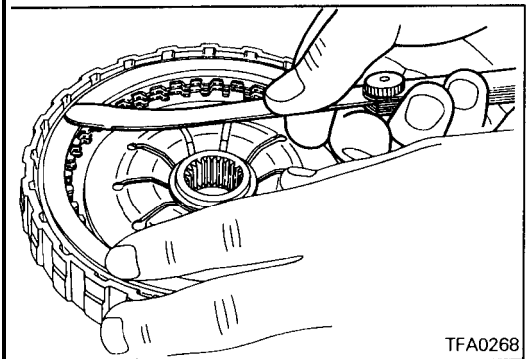
**◆B◆ SNAP RING SELECTION**

- (1) Check clearance between the snap ring and clutch reaction plate. To check the clearance, hold entire circumference of the clutch reaction plate down with 50 N (11 lbs.) force. If clearance is out of standard value, select a snap ring to obtain the standard value.

Standard value: 0.6 – 0.85 mm (.024 – .031 in.)

PLANETARY GEAR

DISASSEMBLY AND REASSEMBLY – W4A32

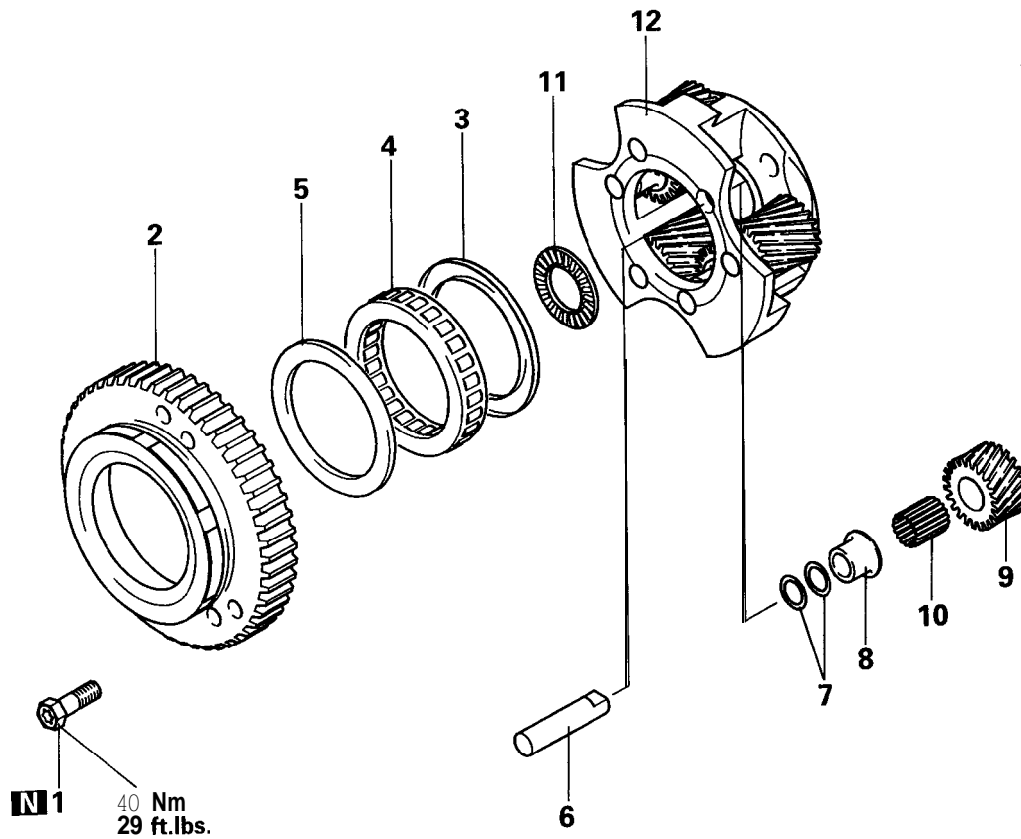

Disassembly steps

1. Bolt
2. One-way clutch outer race
3. End plate
- ▶B▶ 4. One-way clutch
5. End plate
6. Pinion shaft
7. Front thrust washer
8. Spacer bushing
9. Short pinion
10. Roller
- ◀A▶▶A▶ 11. Thrust bearing
12. Planetary carrier

TFA0713

DISASSEMBLY AND REASSEMBLY – F4A33, W4A33

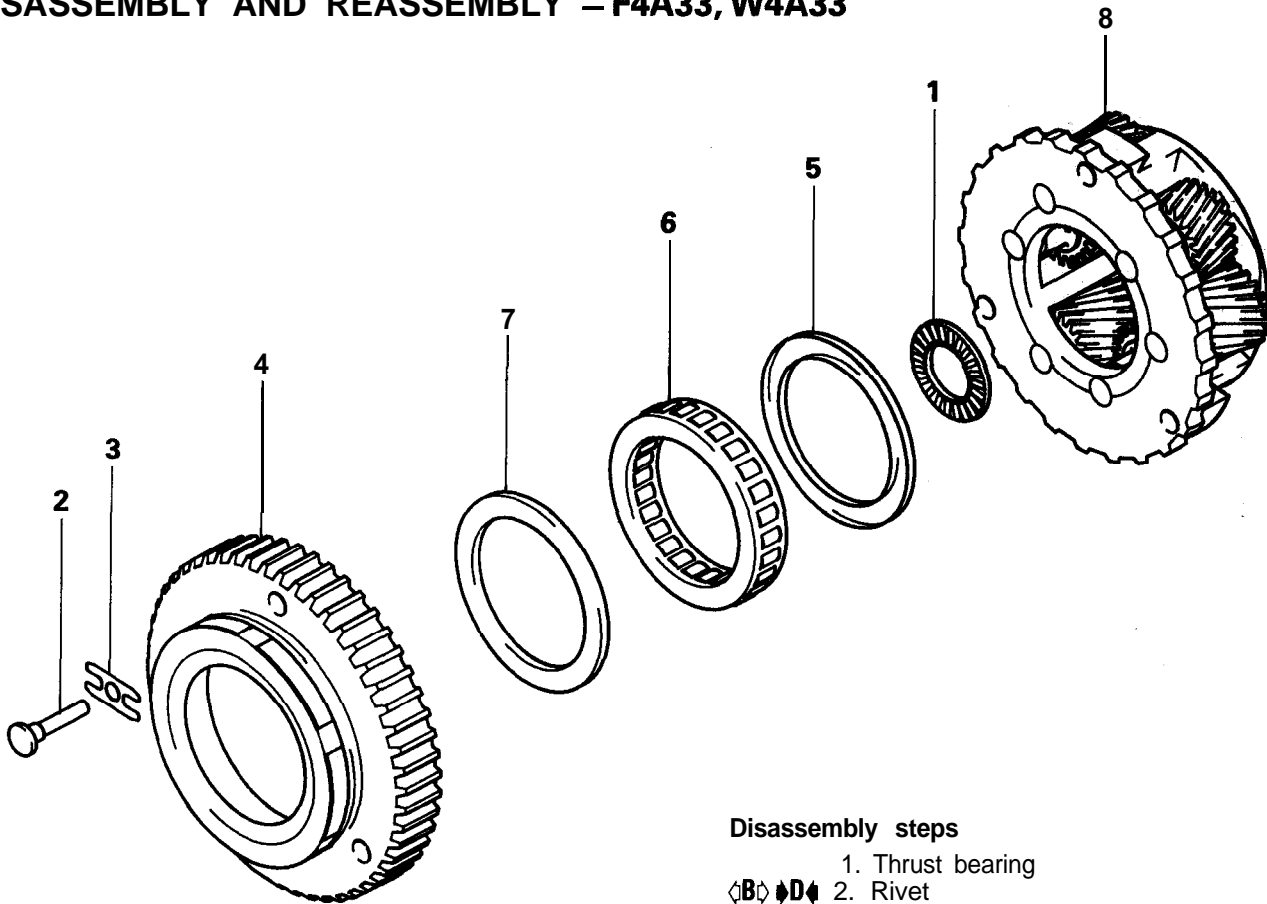

Disassembly steps

- 1. Thrust bearing
- ◁B▷ ▷D◁ 2. Rivet
- ▷C◁ 3. Wave washer
- 4. One way clutch outer race
- 5. End plate
- ▷B◁ 6. One way clutch
- 7. End plate
- 8. Planetary carrier

TFA0491

DISASSEMBLY SERVICE POINTS

◁A▷ THRUST BEARING REMOVAL

- (1) Remove the only one short pinion. Use care not to drop and lose the 17 rollers in the short pinion. Do not remove the other short pinions.

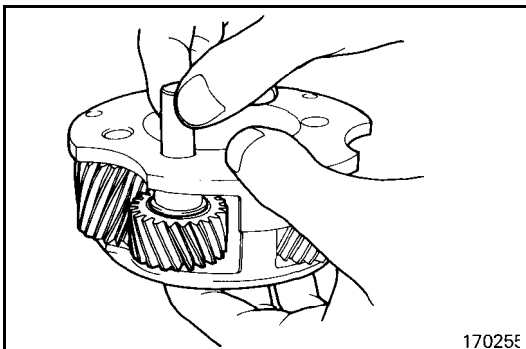

17025E

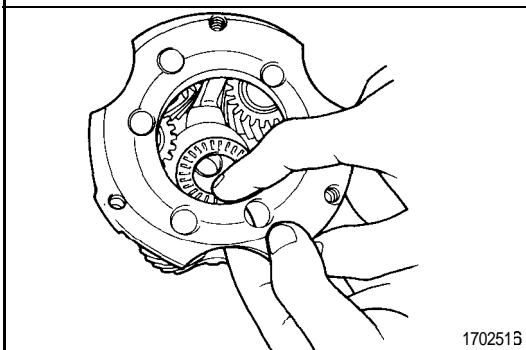

170251B

- (2) Remove the thrust bearing.

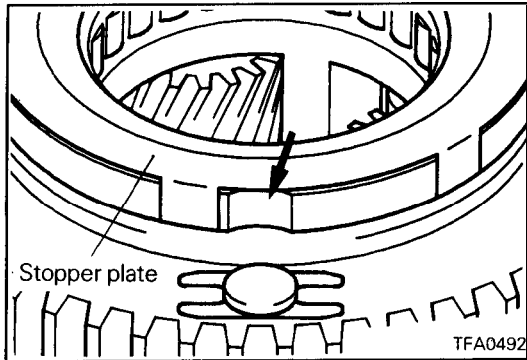

◀B▶ RIVET REMOVAL

- (1) Shift the stopper plate to ensure that the rivet head does not hit it.

NOTE

Make sure that the stopper plate claw is not located at the groove in the one-way clutch outer race.

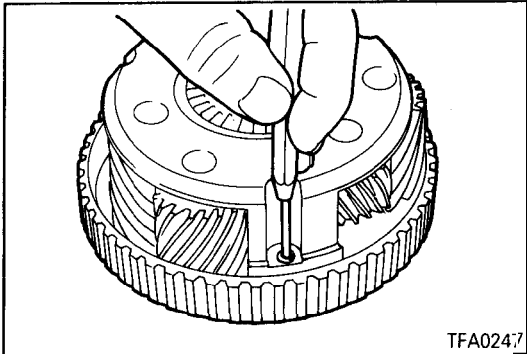

- (2) Using a pin punch, drive out the rivet.

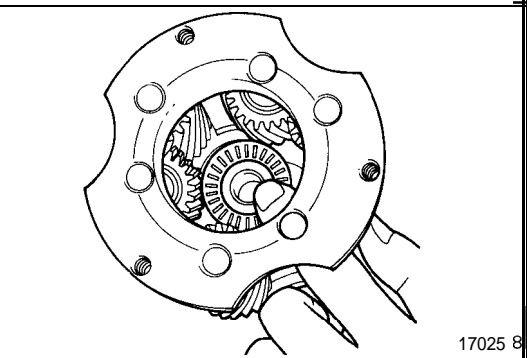

REASSEMBLY SERVICE POINTS

▶A▶ THRUST BEARING INSTALLATION

- (1) Install a new thrust bearing on the carrier. Make sure that it fits correctly in the spot faced portion of the carrier.

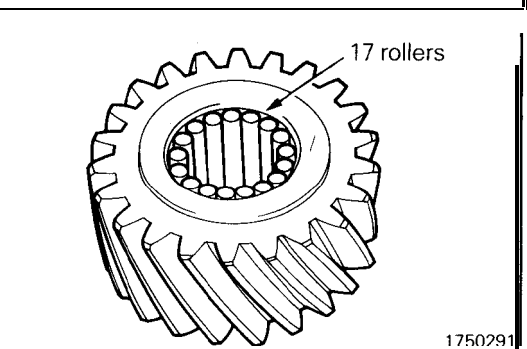

- (2) Apply vaseline unsparingly to the inside surface of the short pinion and attach the 17 rollers on the surface.

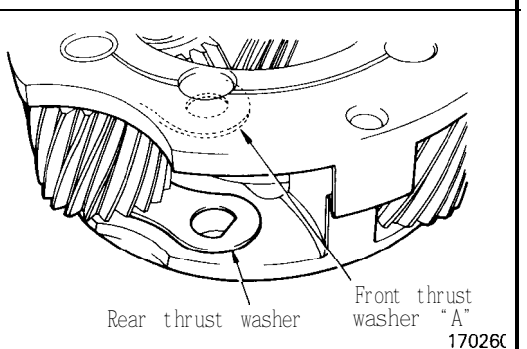

- (3) Line up the holes of the rear thrust washer and front thrust washer "A" with the shaft hole of the carrier.

- (4) Install the short pinion, spacer bushing and front thrust washer and align the holes. Use care not to allow the rollers to get out of position.

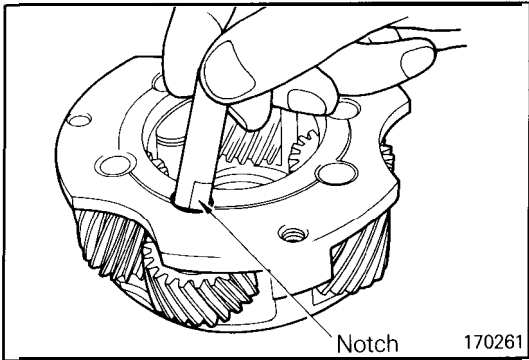

- (5) Insert the pinion shaft. Make sure that the flattened end of pinion shaft is correctly fitted in the hole of the rear thrust plate when the pinion shafts is inserted.

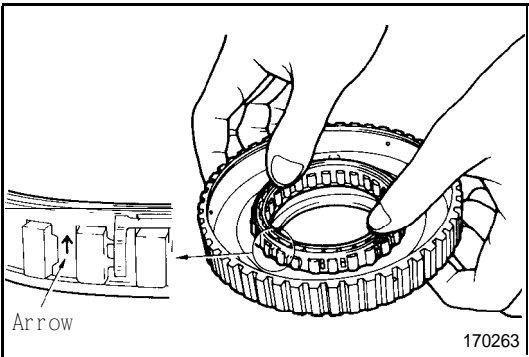

◆B◆ ONE-WAY CLUTCH INSTALLATION

- (1) Push the one-way clutch into the outer race. Make sure that arrow on the outside circumference of cage is directed upward as shown in the illustration when the one-way clutch is pushed in.

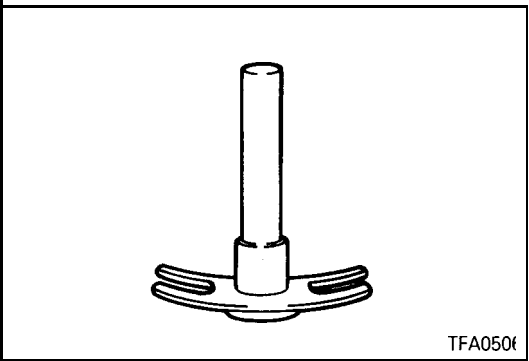

◆C◆ WAVE WASHER INSTALLATION

- (1) Install the wave washer to the rivet so that its indentation is placed on the outer race side.

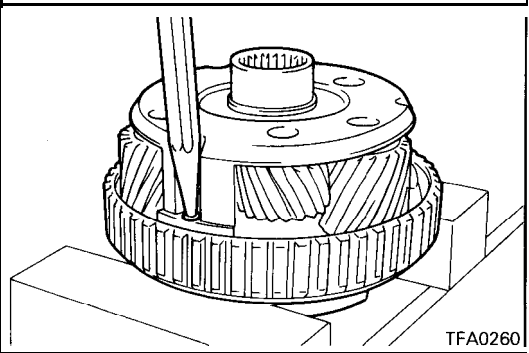

◆D◆ RIVET INSTALLATION

- (1) Stake the rivet using a punch and press.

NOTE

- (1) Use a punch with a 60° tip angle.
 (2) Stake the rivet with a load of 11,000 – 13,000 N (2,425 – 2,866 lbs.).

ANNULUS GEAR AND TRANSFER DRIVE GEAR SET

DISASSEMBLY AND REASSEMBLY

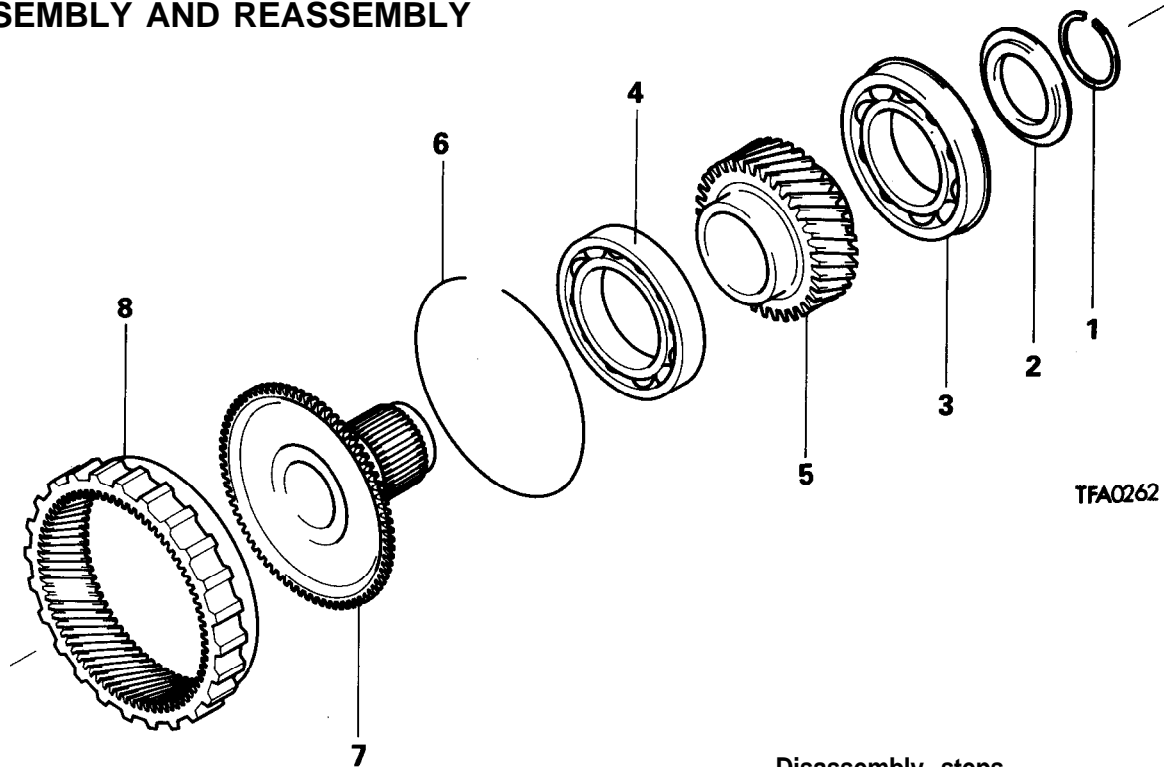

TFA0262

Disassembly steps

- ◆B◆ 1. Snap ring
- 2. Stopper plate
- ◆A◆ ◆A◆ 3. Bearing
- ◆A◆ ◆A◆ 4. Bearing
- ◆A◆ ◆A◆ 5. Transfer drive gear
- 6. Snap ring
- 7. Output flange
- 8. Annulus gear

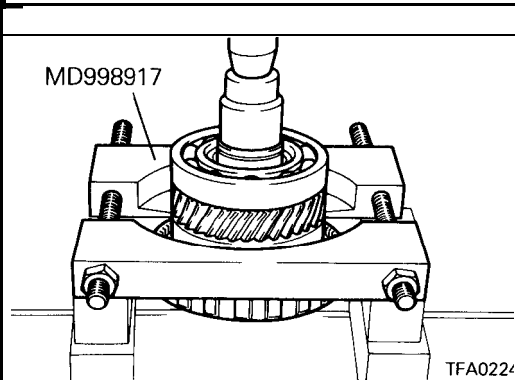

DISASSEMBLY SERVICE POINT

◆A◆ BEARING / TRANSFER DRIVE GEAR REMOVAL

- (1) Using the special tool, remove the transfer drive gear together with two bearings from the output flange.

Caution

Install the special tool in position between the output flange and bearings.

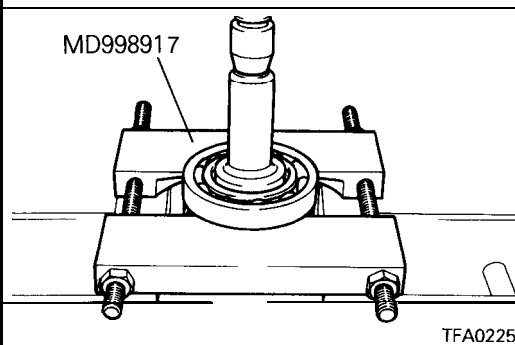

- (2) Using the special tool, remove the bearings from both sides of the transfer drive gear.

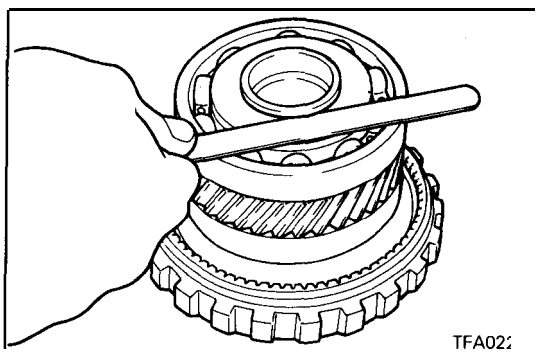
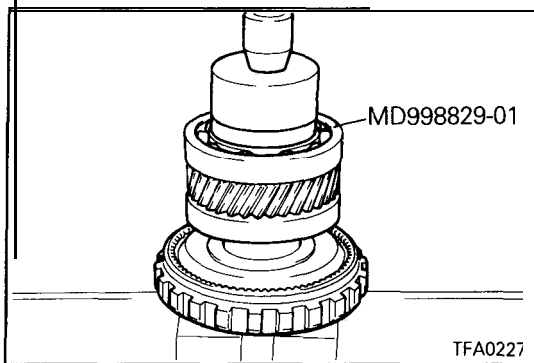
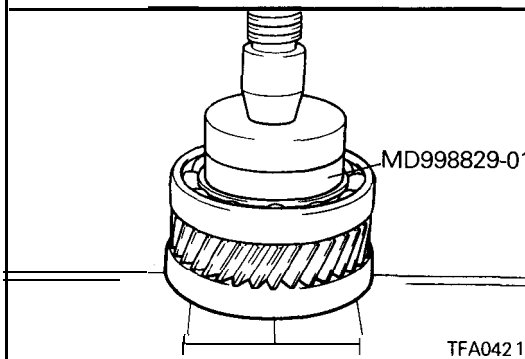
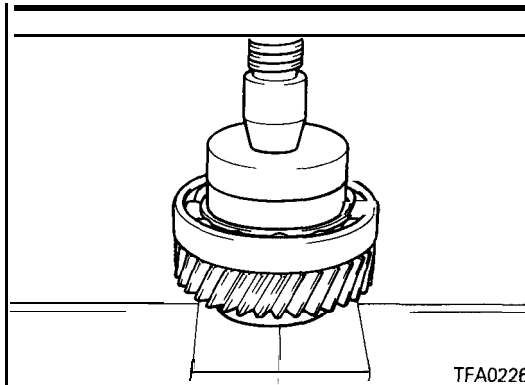

REASSEMBLY SERVICE POINTS

▶A▶ TRANSFER DRIVE GEAR / BEARING INSTALLATION

- (1) Using the special tool, press-fit the bearings into both sides of the transfer drive gear.

- (2) Using the special tool, install the transfer drive gear to the output flange.

▶B▶ SNAP RING SELECTION

- (1) Measure the snap ring groove clearance and select the appropriate spacer to obtain the specified end play.

Standard value: 0 – 0.09 mm (0 – .0035 in.)

DIFFERENTIAL

DISASSEMBLY AND REASSEMBLY

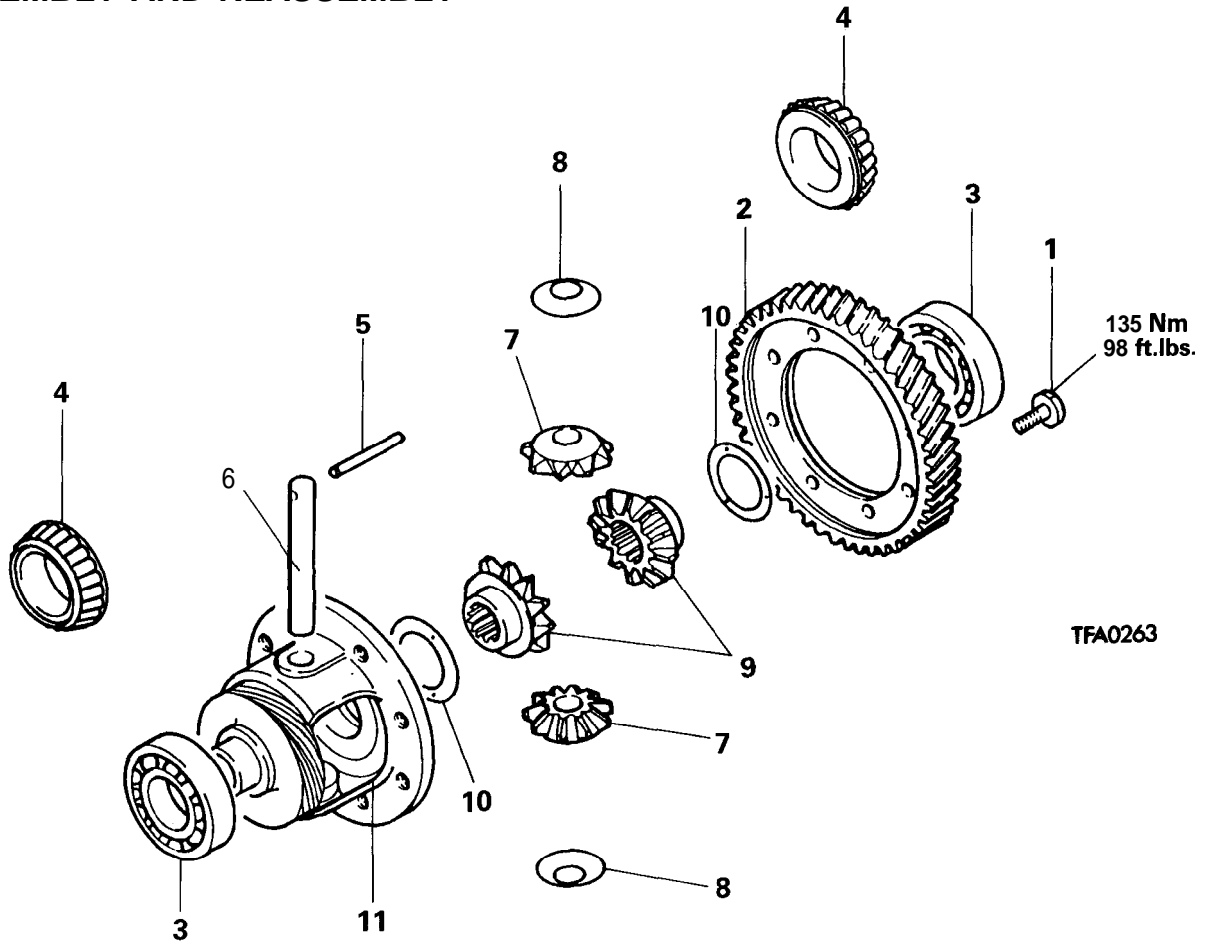

Disassembly steps

- ◆E◆ 1. Bolt
- 2. Differential drive gear
- ◆A◆◆D◆ 3. Ball bearing (W4A32, W4A33)
- ◆B◆◆C◆ 4. Taper roller bearing (F4A33)
- ◆C◆◆B◆ 5. Lock pin
- ◆A◆ 6. Pinion shaft
- ◆A◆ 7. Pinion
- ◆A◆ 8. Washer
- ◆A◆ 9. Side gear
- ◆A◆ 10. Spacer
- 11. Differential case

TFA0263

DISASSEMBLY SERVICE POINTS

◆A◆ **BEARING REMOVAL**

(1) Using the special tool, remove the bearing.

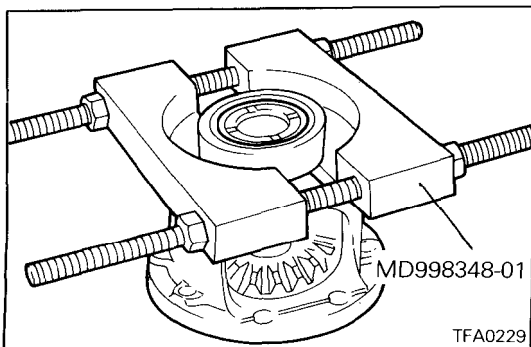

TSB Revision

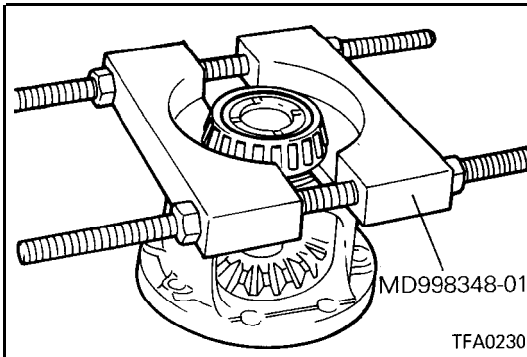

◁B▷ TAPER ROLLER BEARING REMOVAL

- (1) Using the special tool, remove the taper roller bearing.

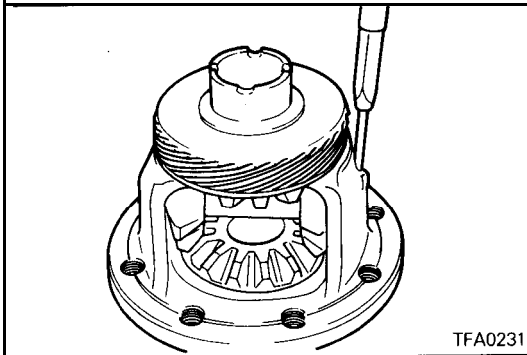

◁C▷ LOCK PIN REMOVAL

- (1) Using a pin punch, drive out the lock pin.

NOTE

Sometimes the lock pin is removed with a light punch.

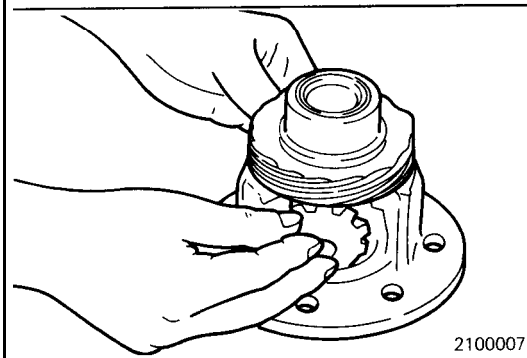

REASSEMBLY SERVICE POINTS

▷A◁ SPACER / SIDE GEAR WASHER / PINION / PINION SHAFT INSTALLATION

- (1) Fit the spacer to the back face of the side gear, then install the gear into the differential case.
- (2) Fit washer to back of pinion and rotate two pinions at the same time into position to mesh with the side gear.

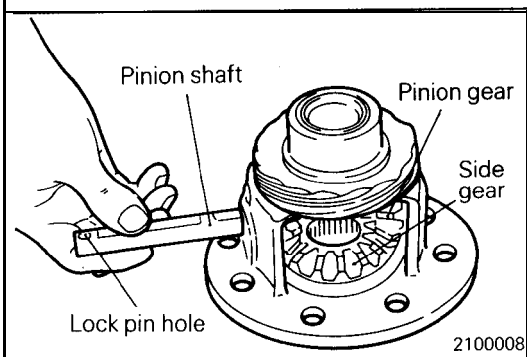

- (3) Insert the pinion shaft.

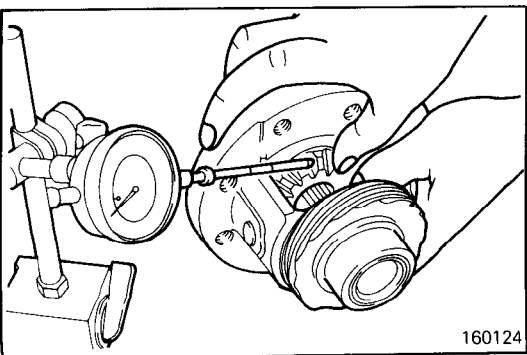

- (4) Measure the backlash between the side gear and pinion.
Standard value: 0.025 – 0.150 mm (.001 – .0059 in.)
- (5) If the backlash is out of specification, select the appropriate spacer and disassemble and reassemble the gears as necessary.

NOTE

Adjust so that the backlash in both side gears equals.

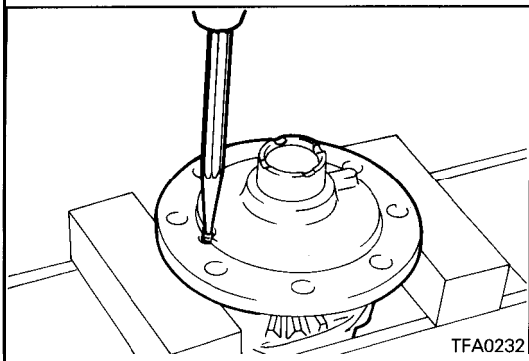

◆B◆ LOCK PIN INSTALLATION

- (1) Align the lock pin hole in pinion shaft with that in the case and install the lock pin.

Caution

1. Do not reuse lock pins
2. Make the lock pin lower than the surface of the differential case flange.
3. Press-fitting load is over 5,000 N (1,100 lbs.)

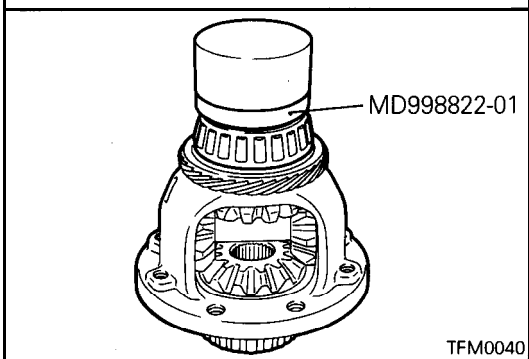

◆C◆ TAPER ROLLER BEARING INSTALLATION

- (1) Using the special tool, press-fit the bearings into both sides of the differential case.

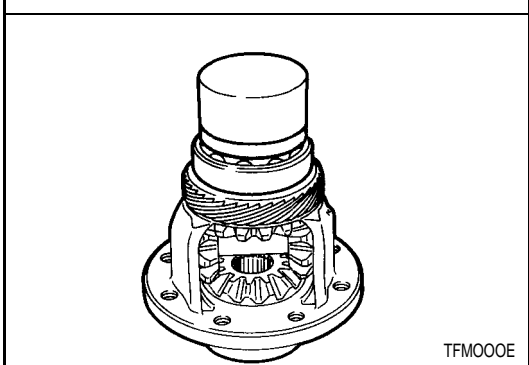

◆D◆ BEARING INSTALLATION

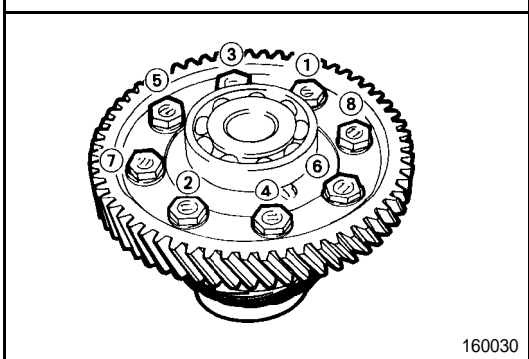

◆E◆ BOLTS INSTALLATION

- (1) Apply ATF to the differential drive gear bolts, install and tighten with specified torque in the order shown in the figure.

Differential drive gear bolt: 135 Nm (98 ft.lbs.)

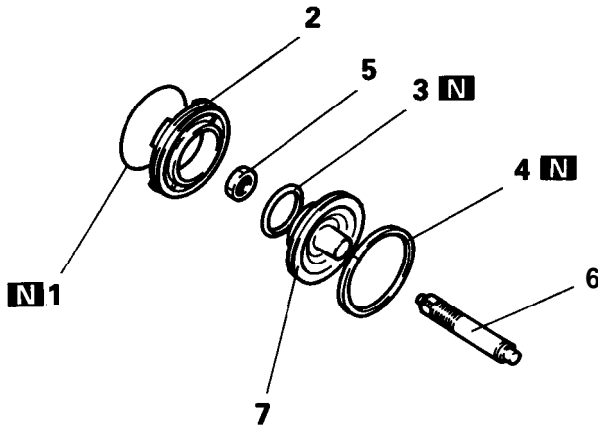
KICKDOWN SERVO**DISASSEMBLY AND REASSEMBLY****Disassembly steps**

1. O-ring
2. Kickdown servo sleeve
3. D-ring
4. Seal ring
5. Lock nut
6. Kickdown servo rod
7. Kickdown servo piston

1750299

LOW-REVERSE BRAKE

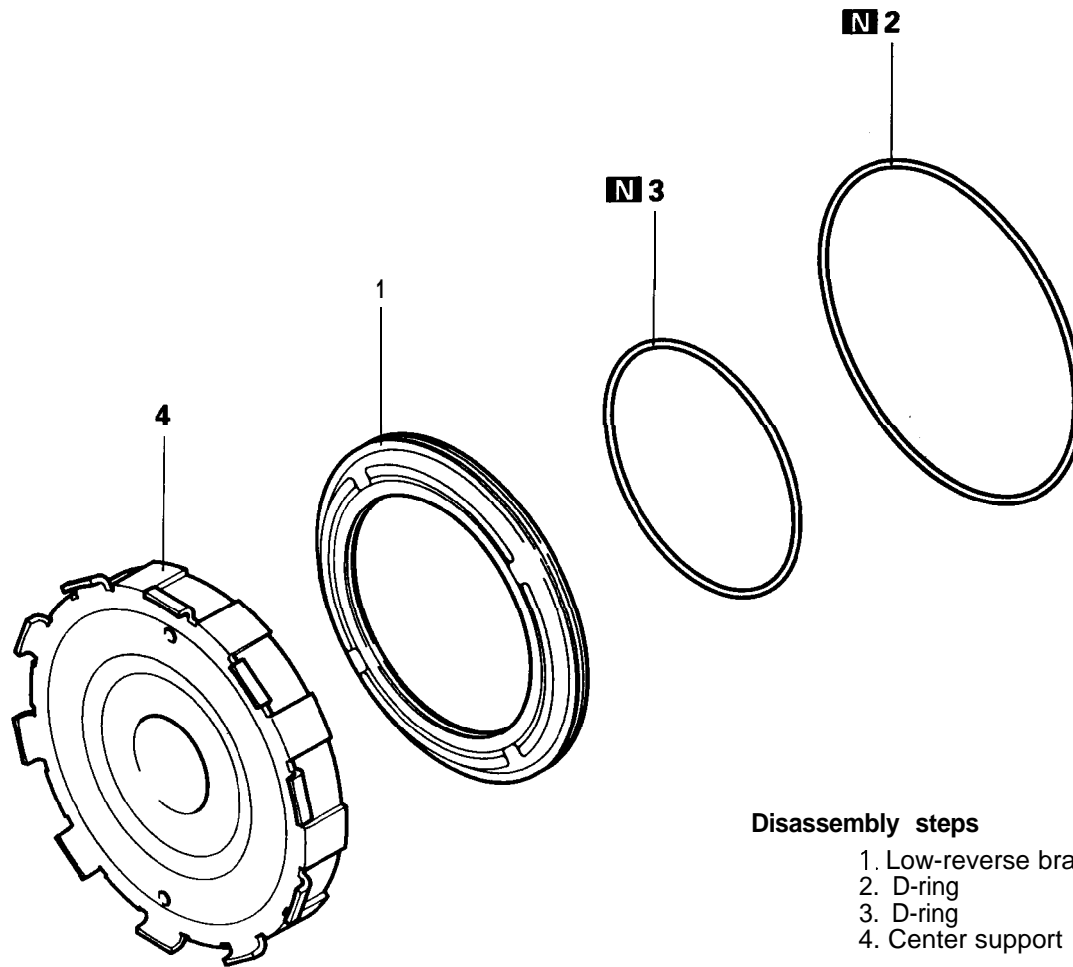

Disassembly steps

1. Low-reverse brake piston
2. D-ring
3. D-ring
4. Center support

TFA0386

SPEEDOMETER GEAR

DISASSEMBLY AND REASSEMBLY

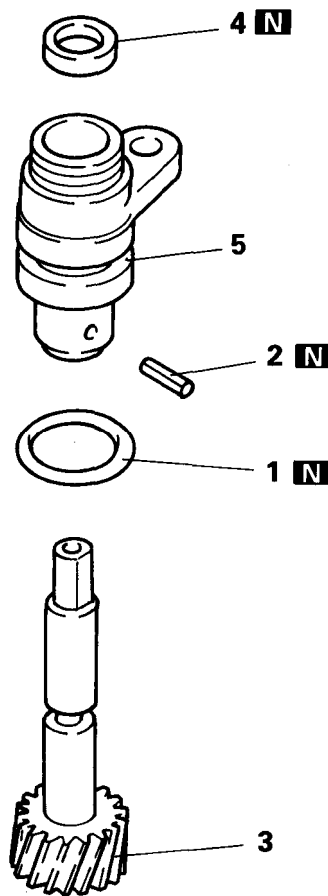

Disassembly steps

1. O-ring
2. Spring pin
3. Driven gear
4. Oil seal
5. Sleeve

201078

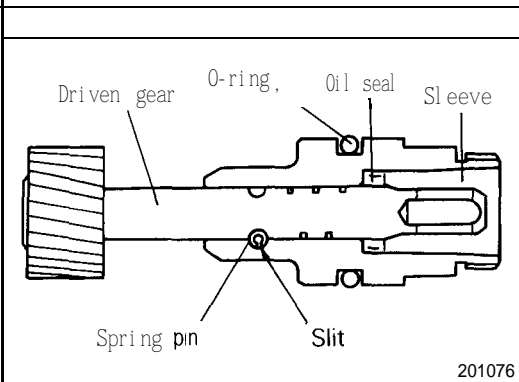

201076

REASSEMBLY SERVICE POINT

◆A◆ SPRING PIN INSTALLATION

- (1) Drive a new spring pin into the sleeve. Make sure that the slit in the spring pin does not face the gear.

VALVE BODY

DISASSEMBLY AND REASSEMBLY

Viewed from A

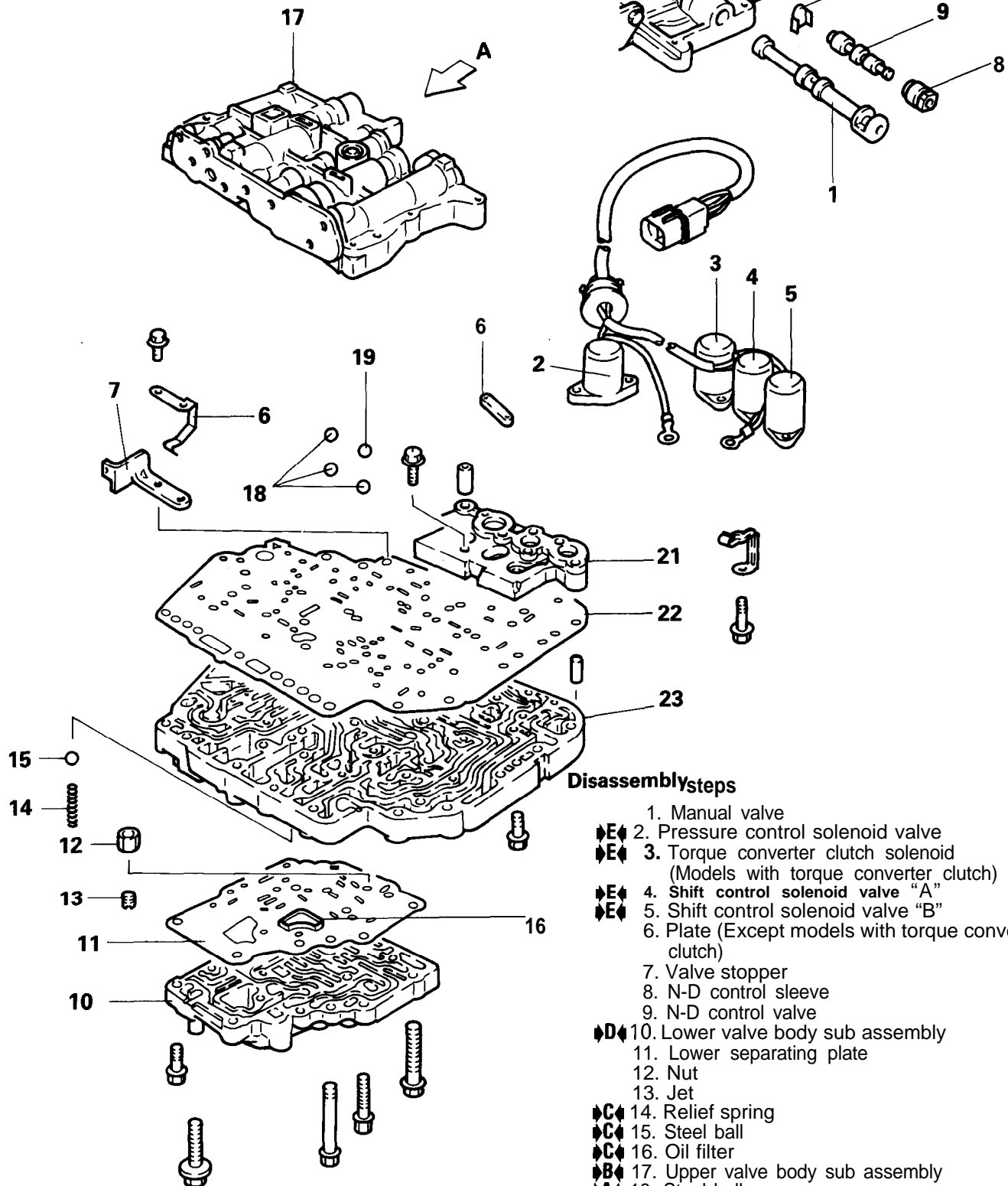

Disassembly steps

1. Manual valve
- ▶E▶ 2. Pressure control solenoid valve
- ▶E▶ 3. Torque converter clutch solenoid (Models with torque converter clutch)
- ▶E▶ 4. Shift control solenoid valve "A"
- ▶E▶ 5. Shift control solenoid valve "B"
6. Plate (Except models with torque converter clutch)
7. Valve stopper
8. N-D control sleeve
9. N-D control valve
- ▶D▶ 10. Lower valve body sub assembly
11. Lower separating plate
12. Nut
13. Jet
- ▶C▶ 14. Relief spring
- ▶C▶ 15. Steel ball
- ▶C▶ 16. Oil filter
- ▶B▶ 17. Upper valve body sub assembly
- ▶A▶ 18. Steel ball
- ▶A▶ 19. Teflon ball
- ▶A▶ 20. N-D plate
21. Block
22. Upper separating plate
23. Intermediate plate

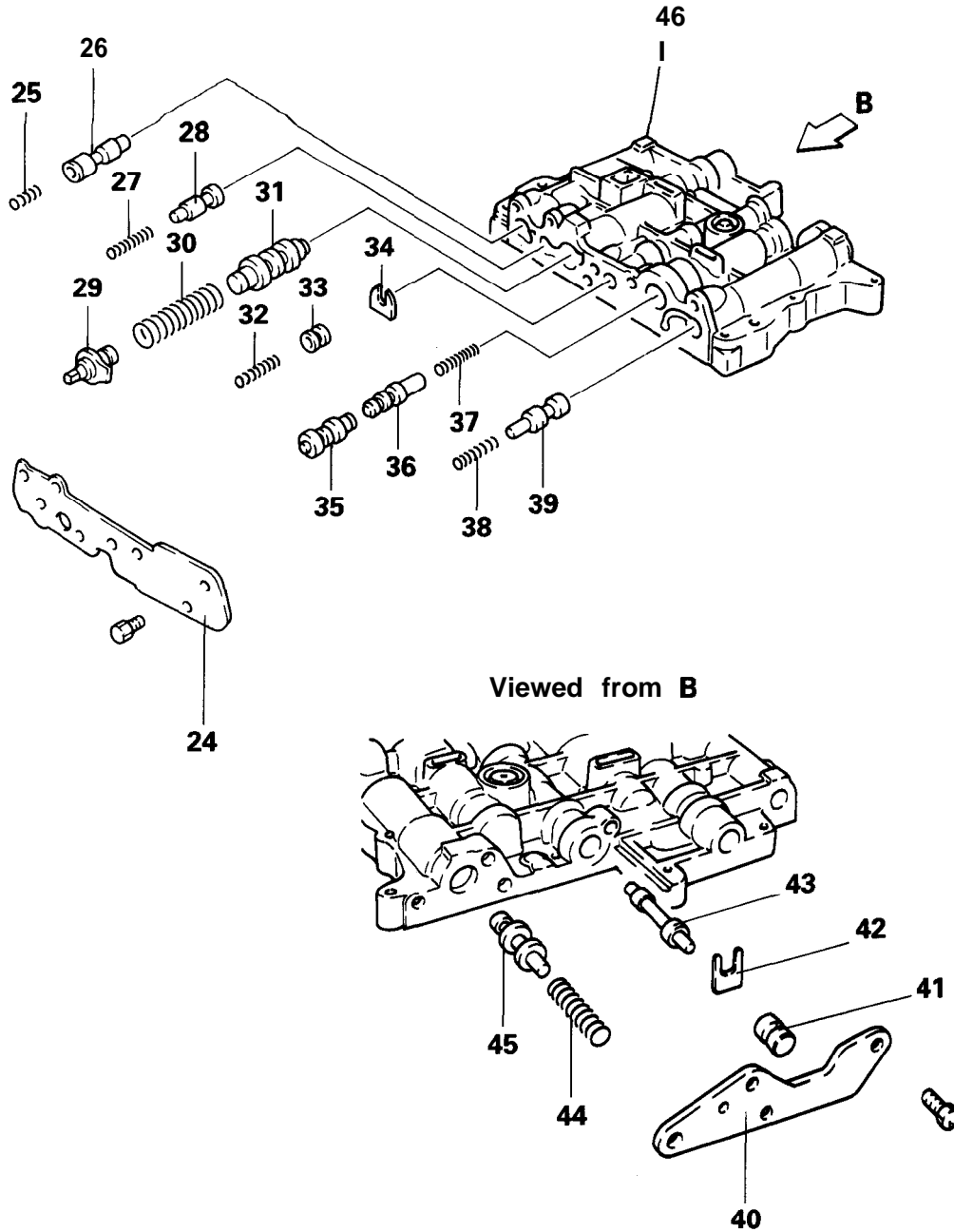

TFA0518

Disassembly steps

- | | |
|--|--|
| <ul style="list-style-type: none"> 24. Front end cover 25. Pressure control spring 26. Pressure control valve 27. Torque converter control spring 28. Torque converter control valve 29. Adjusting screw 30. Regulator spring 31. Regulator valve 32. Shift control spring ▶▶ 33. Stopper plate 34. Shift control plug 35. Rear clutch exhaust valve A | <ul style="list-style-type: none"> 36. Rear clutch exhaust valve B 37. Rear clutch exhaust spring 38. 2-3/4-3 shift spring 39. 2-3/4-3 shift valve 40. Rear end cover 41. Shift control plug B ▶▶ 42. Stopper plate 43. Shift control valve 44. 1-2 shift spring 45. 1-2 shift valve 46. Upper valve body |
|--|--|

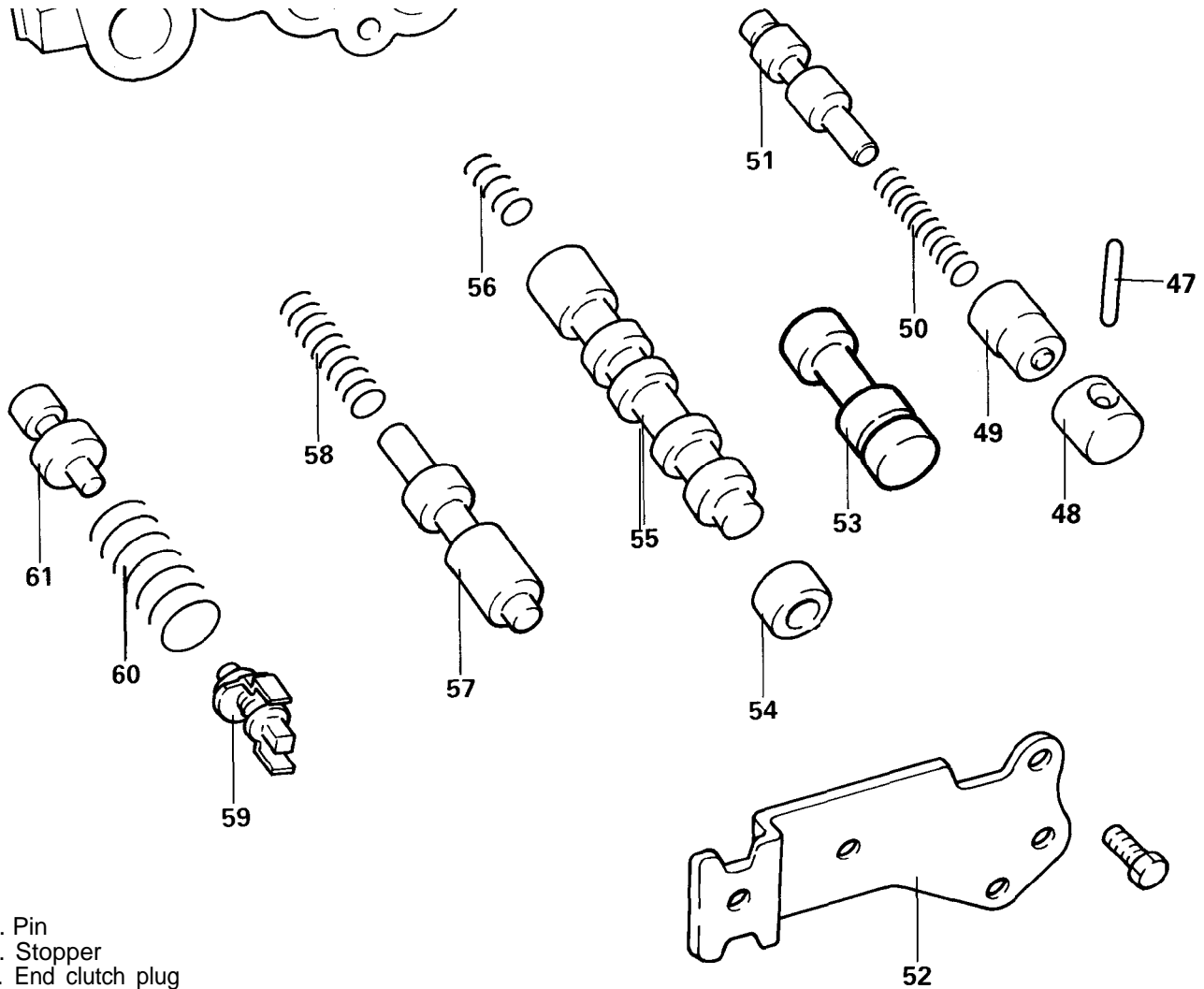

- 47. Pin
 - 48. Stopper
 - 49. End clutch plug
 - 50. End clutch spring
 - 51. End clutch valve
 - 52. End cover
 - 53. Plug (Except models with torque converter clutch)
 - 54. Torque converter clutch control sleeve
 - 55. Torque converter clutch control valve
 - 56. Torque converter clutch control spring
 - 57. N-R control valve
 - 58. N-R control spring
 - 59. Adjusting screw
 - 60. Reducing spring
 - 61. Reducing valve
 - 62. Lower valve body
- } Models with torque converter clutch

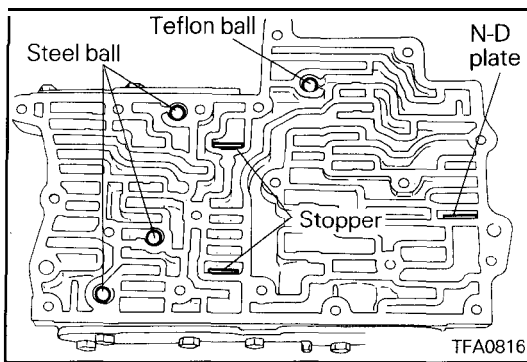

▶A▶ STOPPER PLATE / N-D PLATE / TEFLON BALL / STEEL BALL LOCATION

- (1) Install the stopper plates, N-D plate, teflon ball, and steel balls into the upper valve body as shown.

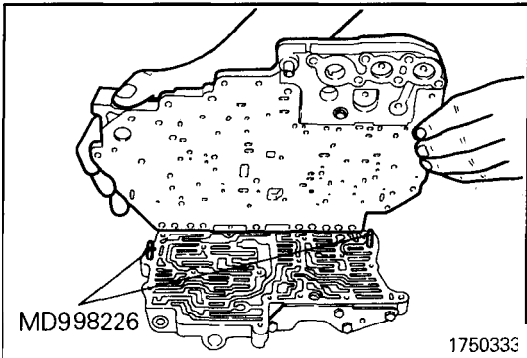

▶B▶ UPPER VALVE BODY SUB ASSEMBLY INSTALLATION

- (1) Install the special tool and secure the upper separating plate and intermediate plate with eight mounting bolts. Then, remove the special tool.

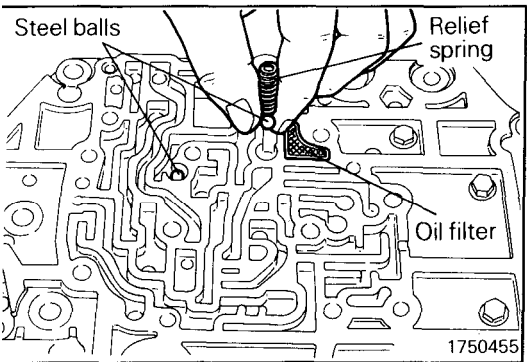

▶C▶ OIL FILTER / STEEL BALL / RELIEF SPRING INSTALLATION

- (1) Install the oil filter, two steel balls, and spring to the intermediate plate.

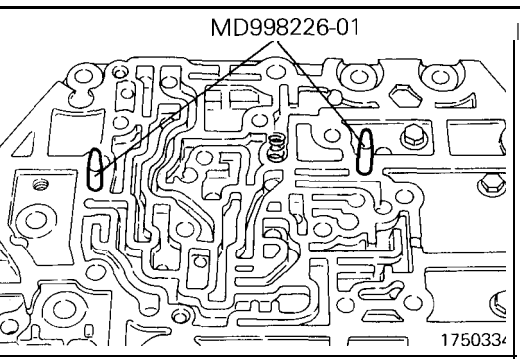

▶D▶ LOWER VALVE BODY SUB ASSEMBLY INSTALLATION

- (1) Mount the special tool to the intermediate plate.

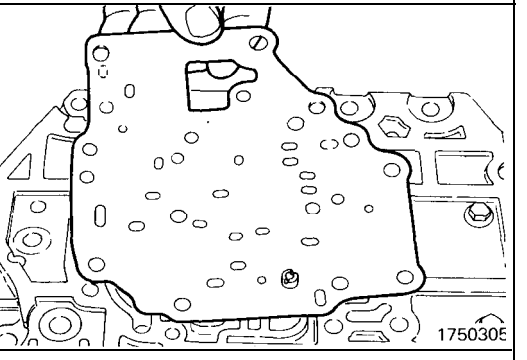

- (2) Install the separating plate.

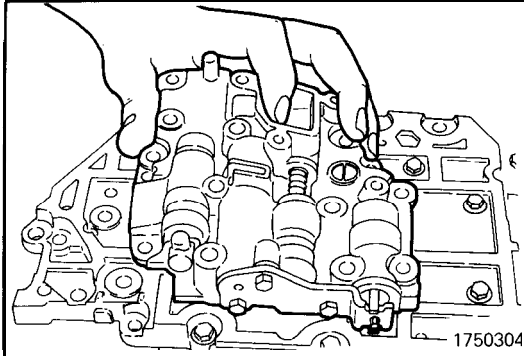

(3) Secure the lower valve body with mounting bolts and then remove the special tool.

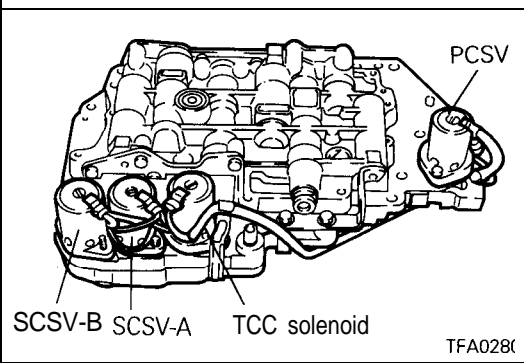

SOLENOID VALVE ASSEMBLY INSTALLATION

(1) Install the solenoid valves as shown.

Solenoid valve	Wire color
Shift control solenoid valve A (SCSV-A)	Orange
Shift control solenoid valve B (SCSV-B)	Yellow
Torque converter clutch solenoid (TCC solenoid)	Red
Pressure control solenoid valve (PCSV)	Blue

TRANSFER SHAFT – FWD
DISASSEMBLY AND REASSEMBLY

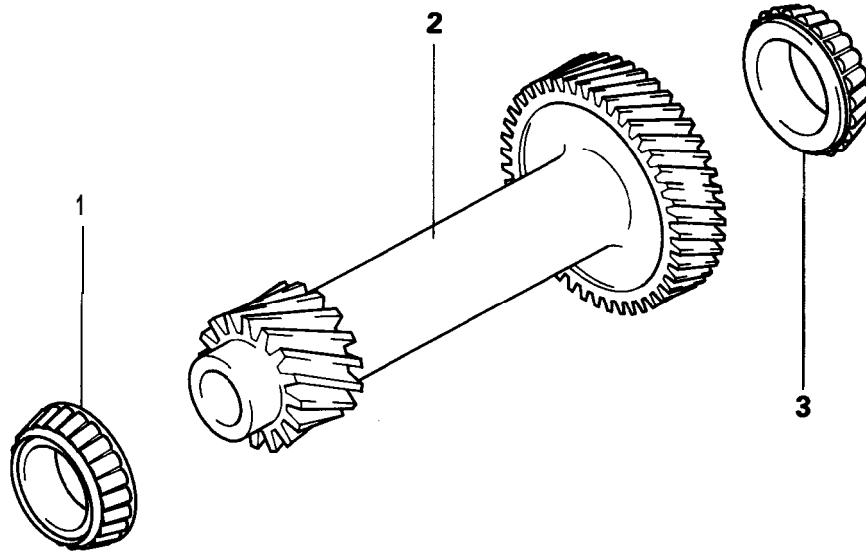

TFA0322

Disassembly steps

- ◁A▷ ▷B◁ 1. Taper roller bearing
- ▷A◁ 2. Transfer shaft
- ◁A▷ ▷A◁ 3. Taper roller bearing

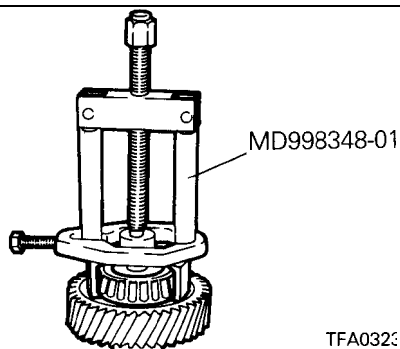

TFA0323

DISASSEMBLY SERVICE POINT

◁A▷ TAPER ROLLER BEARING REMOVAL

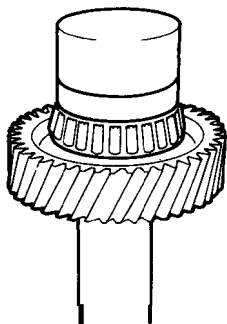

TFA0325

REASSEMBLY SERVICE POINTS

▷A◁ TAPER ROLLER BEARING INSTALLATION

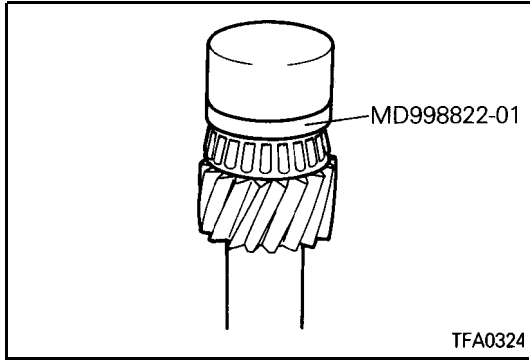

⇨B⇩ TAPER ROLLER BEARING INSTALLATION

TFA0324

CENTER DIFFERENTIAL – 4WD

DISASSEMBLY AND REASSEMBLY

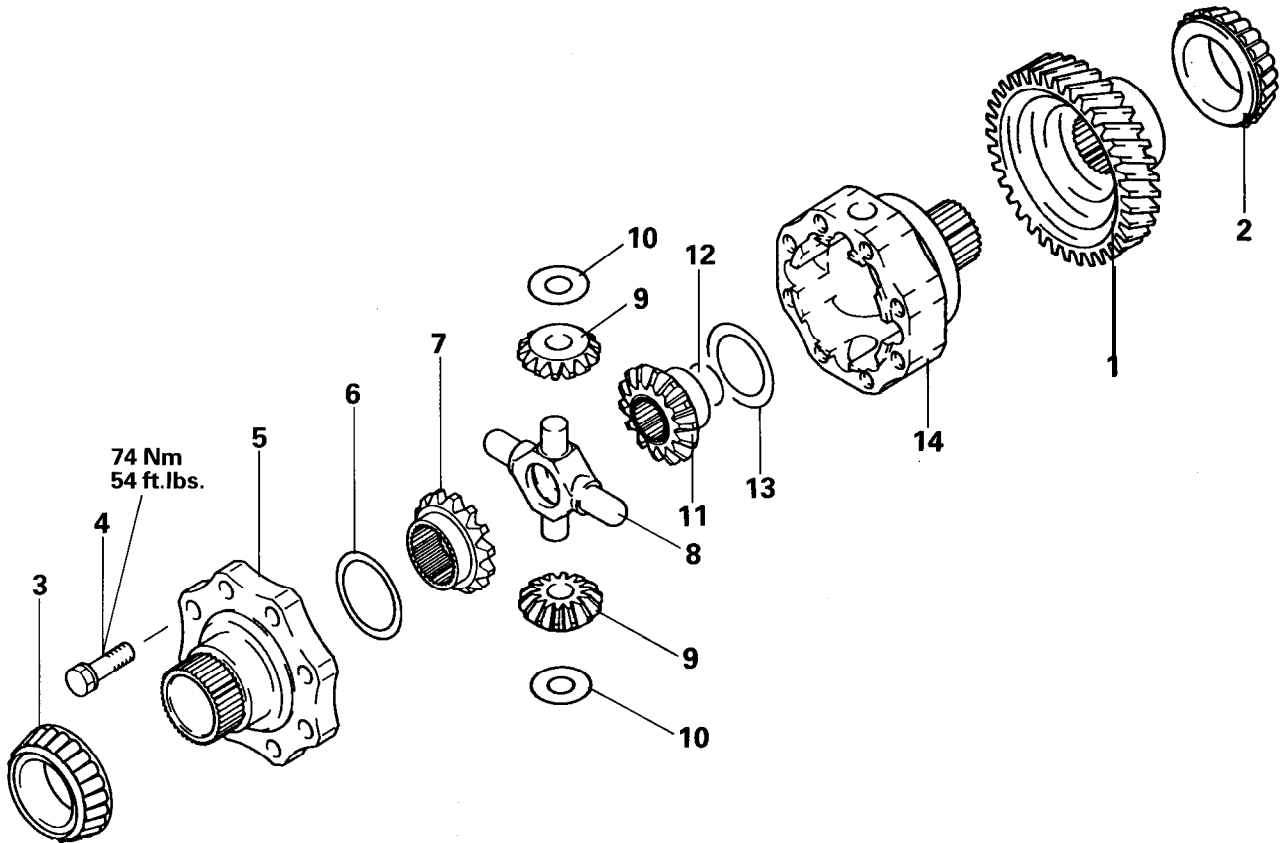

Disassembly steps

- ◊A◊ 1. Transfer driven gear
- ◊B◊ ◊D◊ 2. Taper roller bearing
- ◊C◊ ◊C◊ 3. Taper roller bearing
- ◊B◊ 4. Bolt
- 5. Center differential flange
- ◊A◊ 6. Spacer
- 7. Side gear (front)
- 8. Pinion shaft
- 9. Pinion
- 10. Washer
- 11. Side gear (rear)
- 12. Clip
- ◊A◊ 13. Spacer
- 14. Center differential case

TFA0261

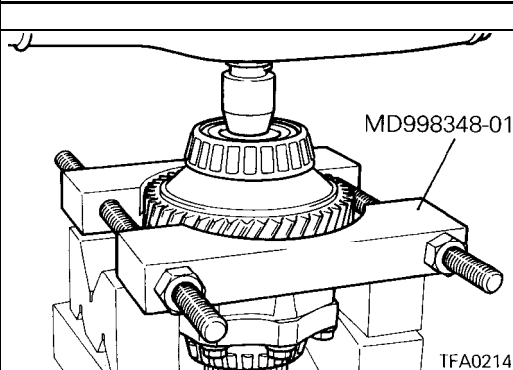

DISASSEMBLY SERVICE POINTS

◊A◊ TRANSFER DRIVEN GEAR REMOVAL

- (1) Remove the transfer driven gear.

NOTE

If it is hard to remove, use the special tool to remove it.

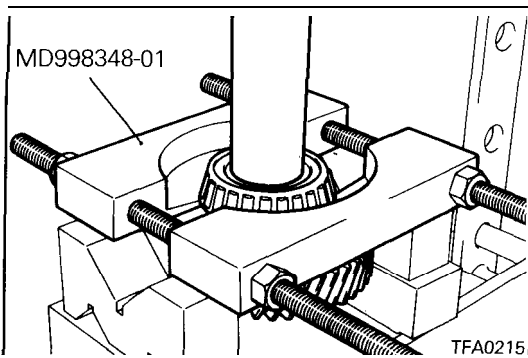

⇄B⇄ TAPER ROLLER BEARING REMOVAL

- (1) Using the special tool, remove the taper roller bearing from the transfer driven gear.

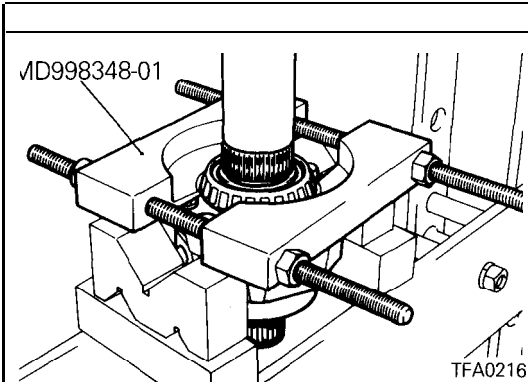

⇄C⇄ TAPER ROLLER BEARING REMOVAL

- (1) Using the special tool, remove the taper roller bearing from the center differential flange.

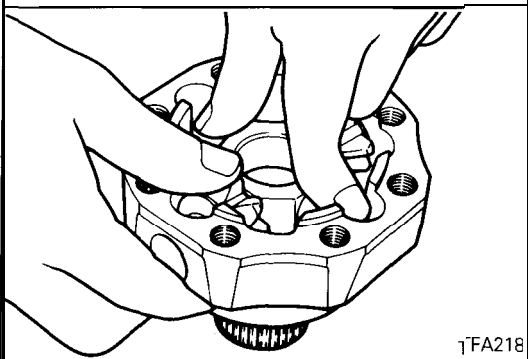

REASSEMBLY SERVICE POINTS

▶A▶ SPACERS SELECTION

- (1) install the spacer, side gear (rear), pinion, washer and pinion shaft in the center differential case.
- (2) While pressing the pinion shaft, select the thickest spacer to gently rotate the pinion.

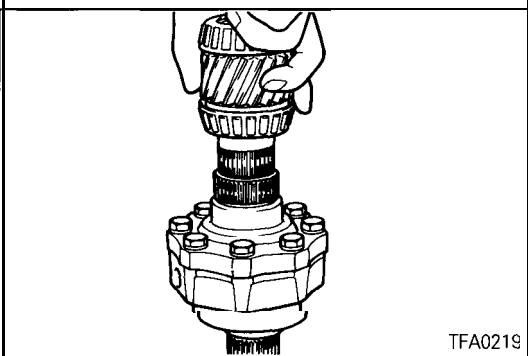

- (3) Install the side gear (front), spacer and center differential flange and tighten the bolts with the specified torque.

Center differential drive gear bolt: 75 Nm (54 ft.lbs.)

- (4) Using the front output shaft, rotate the side gear front and select the thickest spacer to gently rotate the side gear front.

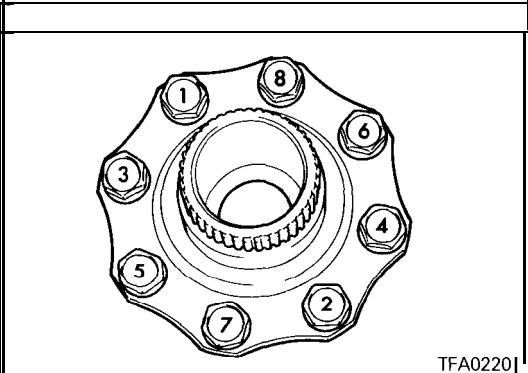

▶B▶ BOLT INSTALLATION

- (1) First apply sealant to the end [5 mm (.2 in.)] of the bolt threads and then tighten to the specified torque in the order shown in the figure.

Center differential drive gear bolt: 75 Nm (54 ft.lbs.)

Specified adhesive:

3M Stud Locking Part No. 4170 or equivalent

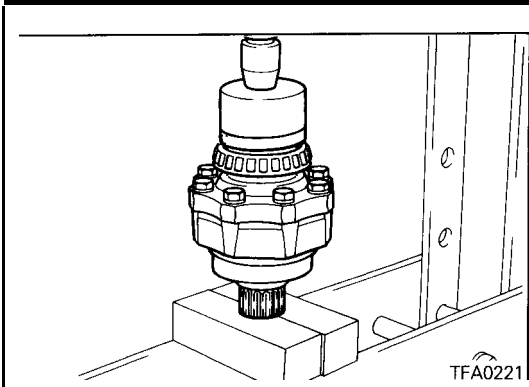

◆C◆ TAPER ROLLER BEARING INSTALLATION

- (1) Using the special tool, install the taper roller bearing on the center differential flange.

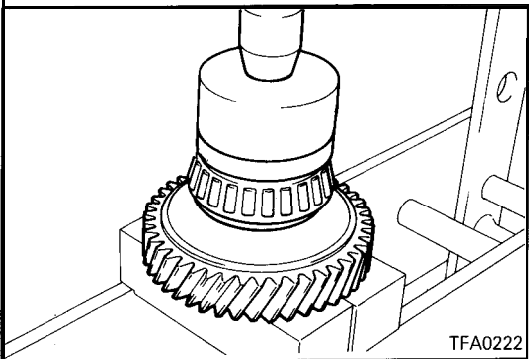

◆D◆ TAPER ROLLER BEARING INSTALLATION

- (1) Using the special tool, install the taper roller bearing on the transfer driven gear.

FRONT OUTPUT SHAFT – 4WD

DISASSEMBLY AND REASSEMBLY

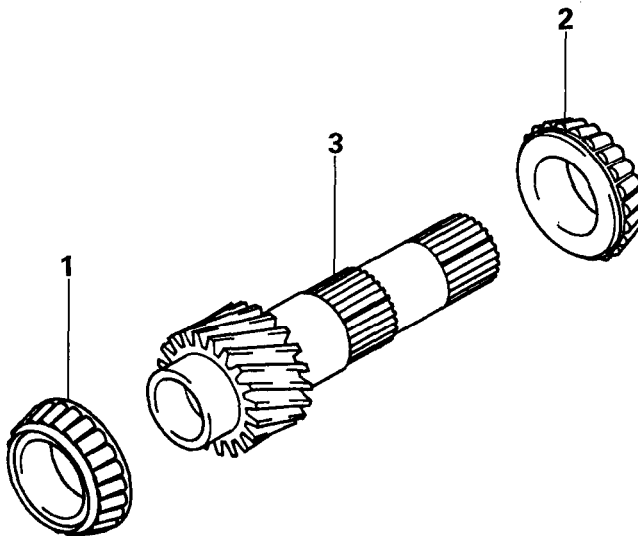

Disassembly steps

- ◁A▷ ▷A◁ 1. Taper roller bearing
- ◁A▷ ▷A◁ 2. Taper roller bearing
- 3. Front output shaft

TFA0244

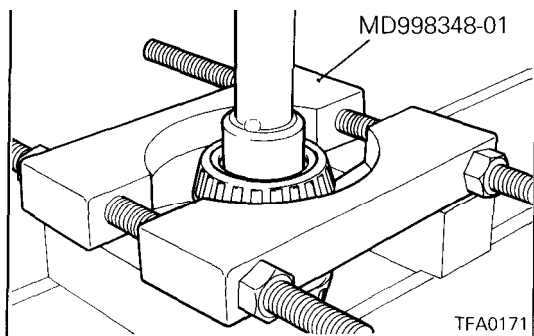

DISASSEMBLY SERVICE POINT

◁A▷ **TAPER ROLLER BEARINGS REMOVAL**

- (1) Using the special tool, remove the taper roller bearings on both ends of the front output shaft.

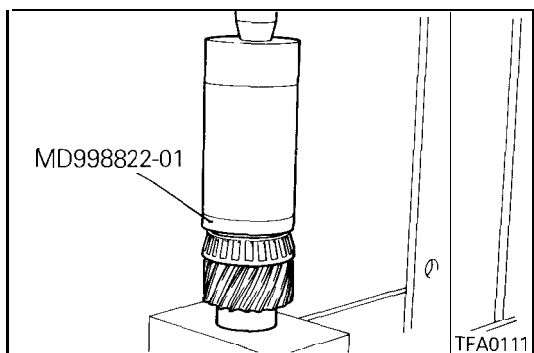

REASSEMBLY SERVICE POINT

▷A◁ **TAPER ROLLER BEARINGS INSTALLATION**

- (1) Using the special tool, press-fit the taper roller bearings on both ends of the front output shaft.

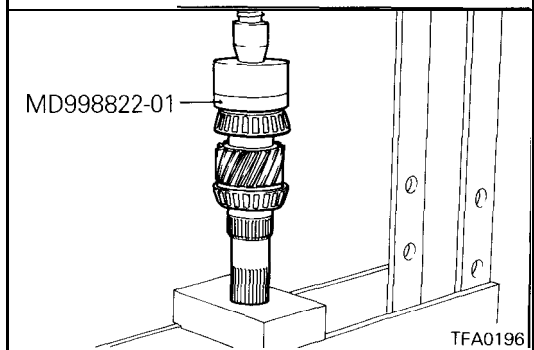

TRANSFER – 4WD

DISASSEMBLY AND REASSEMBLY

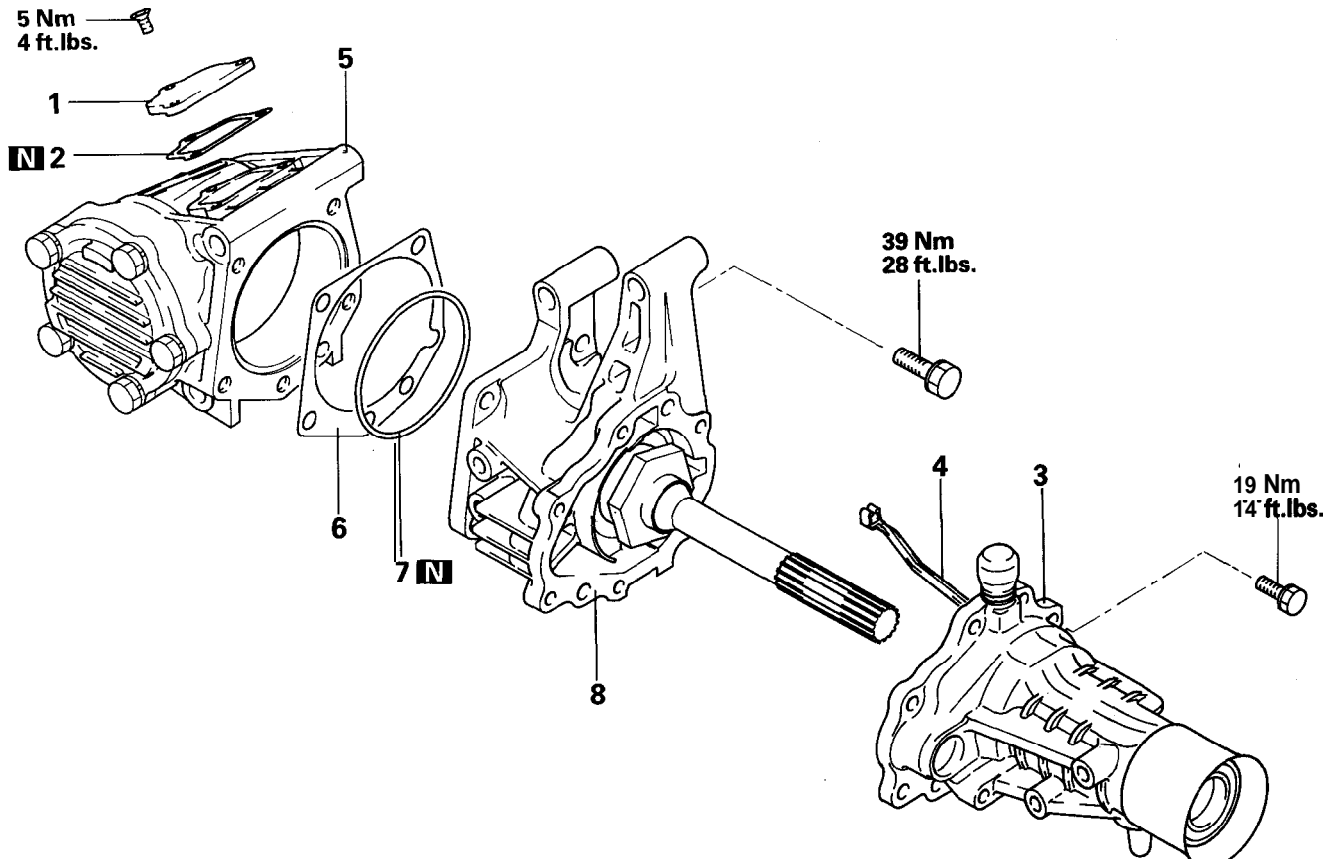

Disassembly steps

1. Cover
- ▶E▶ 2. Cover gasket
- ▶D▶ 3. Extension housing assembly
4. Oil guide
- ▶C▶ 5. Transfer case sub assembly
- ▶B▶ 6. Spacer
7. O-ring
- ▶A▶ 8. Transfer case adapter sub assembly

TFA0601

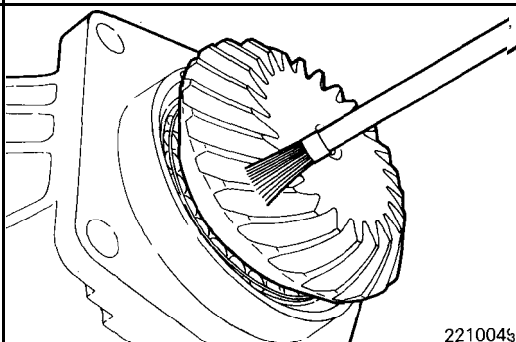

221004s

REASSEMBLY SERVICE POINTS

▶A▶ TRANSFER CASE ADAPTER SUB ASSEMBLY INSTALLATION

- (1) Apply a light and uniform coat of machine blue or red lead to the driven bevel gear teeth (both sides) using a brush.

TSB Revision

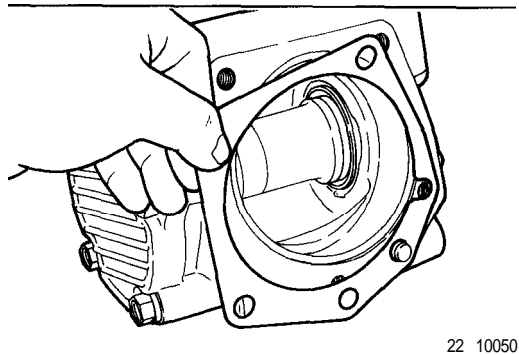

22 10050

◆B◆ SPACER INSTALLATION

- (1) Install the spacer that has been used.

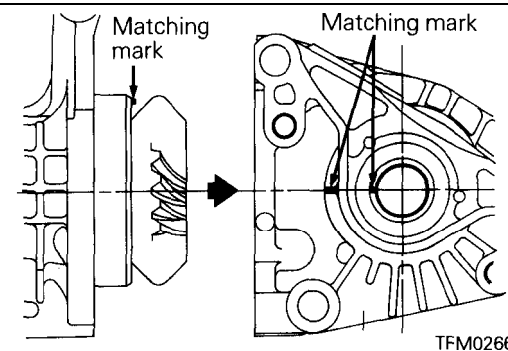

TFM026f

◆C◆ TRANSFER CASE SUB ASSEMBLY INSTALLATION

- (1) With the matching marks in alignment, install the transfer case adapter sub assembly to the transfer case sub assembly.

- (2) Tighten the transfer case adapter sub assembly to the transfer case sub assembly to specified torque.

Transfer case adapter mounting bolt: 39 Nm (28 ft.lbs.)

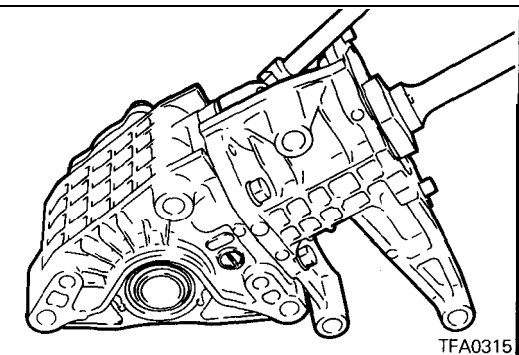

TFA0315

- (3) Using the special tool, turn the drive bevel gear shaft (one turn in normal direction, one turn in reverse direction).

NOTE

Do not give the drive bevel gear shaft more than one turn in either direction as this causes unclear tooth contact pattern.

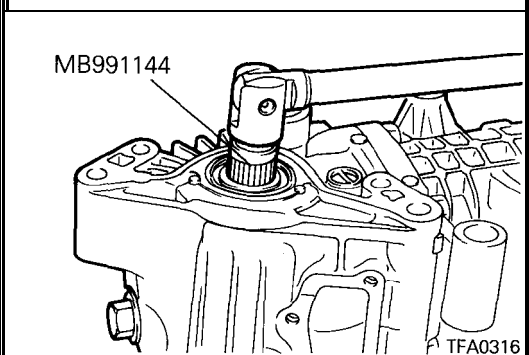

TFA0316

- (4) Make sure that the driven bevel gear and transfer case matching marks are in alignment.

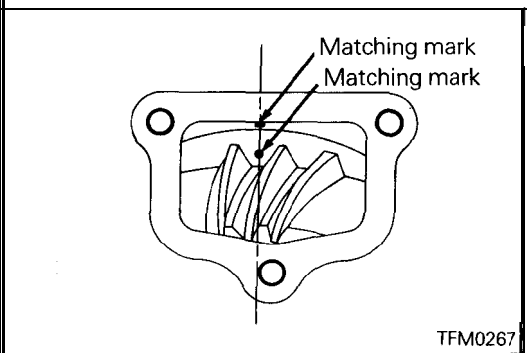

TFM0267

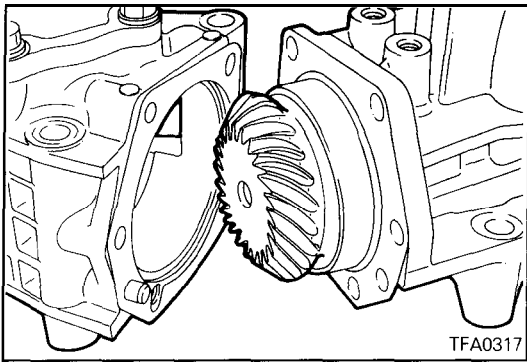

(5) Check to see if the drive bevel gear tooth contact is normal.

NOTE

Refer to the TOOTH CONTACT ADJUSTMENT PROCEDURES on next page (below) for the standard tooth contact.

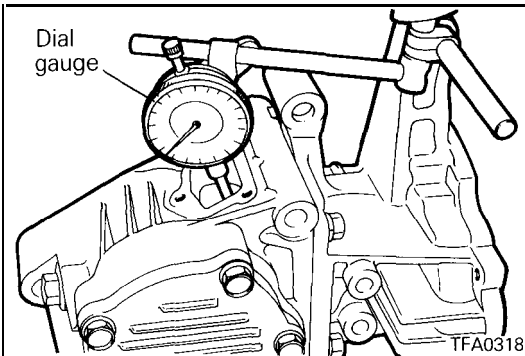

(6) Check to see if the drive bevel gear and driven bevel backlash is as specified.

Standard value: Bevel gear set backlash
0.08 – 0.13 (.0031 – .0051 in.)

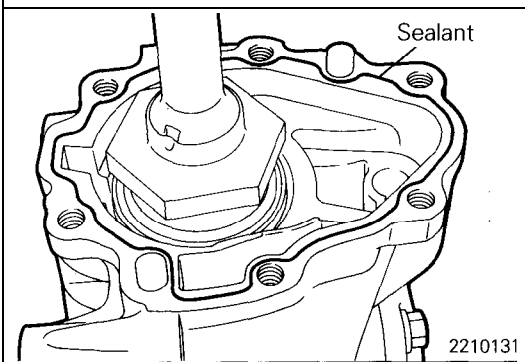

◆◆ EXTENSION HOUSING INSTALLATION

(1) Apply sealant to the adapter flange surface and install the extension housing.

Specified sealant:

Mitsubishi genuine sealant Part No. MD997740 or equivalent

NOTE

Squeeze out sealant from the tube uniformly and continuously in adequate amount.

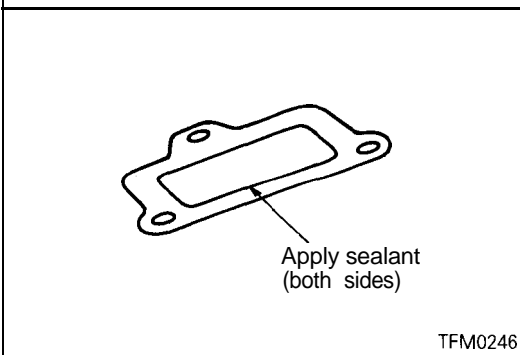

◆◆ SEALANT TO COVER GASKET APPLICATION

Specified sealant:

3M ATD Part No. 8660 or equivalent

TOOTH CONTACT ADJUSTING PROCEDURES

1. Standard tooth contact pattern

- A Small end side
- B . . Drive side tooth face
(Side on which force acts when running forward)
- C Big end side
- D.... Coast side tooth face
(Side on which force acts when reversing)

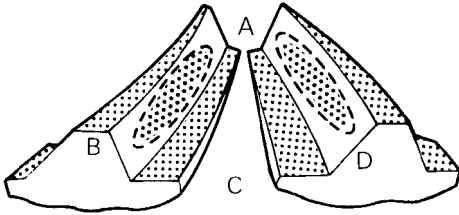

2210061

2. Tooth contact pattern produced when drive bevel gear height is too large

Cause
The driven bevel is too close to the drive bevel gear.

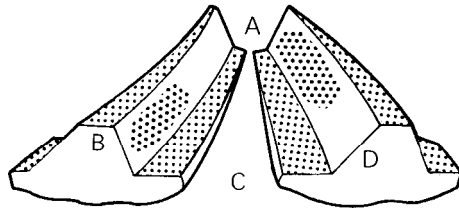

2210092

Remedy
Use thicker bevel gear mount adjusting spacer to separate the driven bevel gear more from the drive bevel gear.

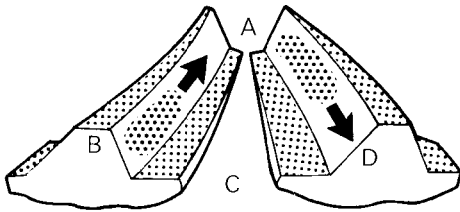

2210093

3. Tooth contact pattern produced when driven bevel gear height is too small

Cause
The driven bevel gear is too separated from the drive bevel gear.

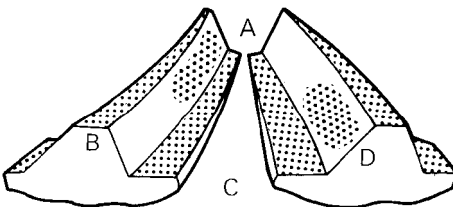

2210094

Remedy
Use thinner driven bevel gear mount adjusting spacer to bring the driven bevel gear more closer to the drive bevel gear.

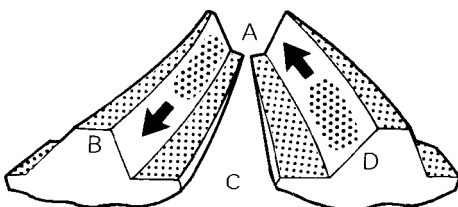

2210095

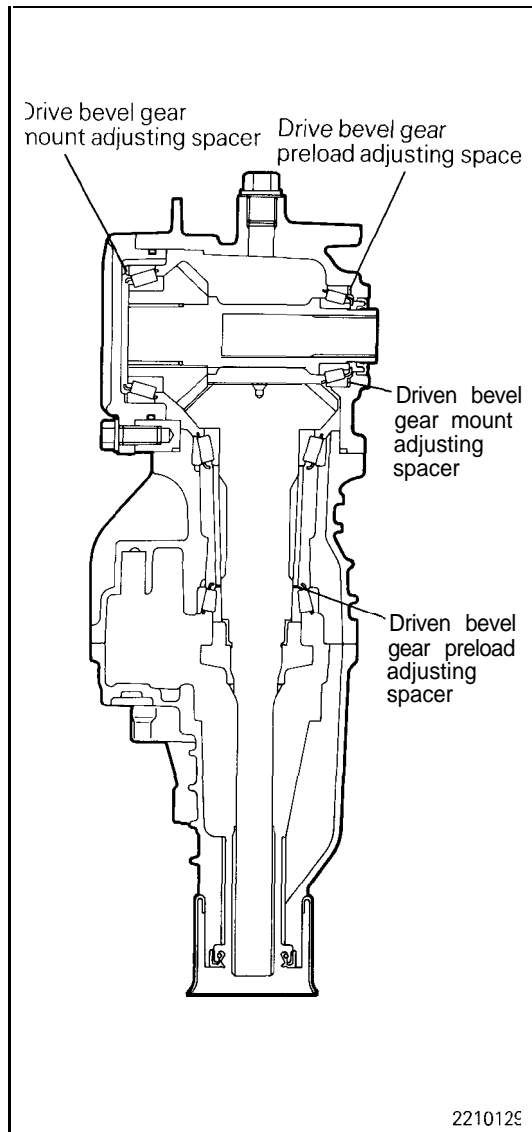

NOTE

- (1) If correct tooth contact cannot be obtained even by change of the driven bevel gear mount adjusting spacer, increase or decrease the drive bevel gear preload adjusting spacer and the drive bevel gear mount adjusting spacer as described below and then adjust tooth contact again.
 - When the driven bevel gear height is too small even if the thinnest driven bevel gear mount adjusting spacer 0.13 mm (.0051 in.) is used:
 Replace the drive bevel gear mount adjusting spacer that is in use with one that is one rank thicker and replace the drive bevel preload adjusting spacer that is in use with one that is one rank thinner.
 - When the driven bevel gear height is too large even if the thickest driven bevel gear mount adjusting spacer 0.52 (.025 in.) is used:
 Replace the drive bevel gear mount adjusting spacer that is in use with one that is one rank thinner and replace the drive bevel gear preload adjusting spacer that is in use with one that is one rank thicker.
 Repeat above steps until the tooth contact pattern equal or close to the standard pattern is obtained.
- (2) If the tooth contact pattern cannot be adjusted close to the standard pattern by above adjustment, replace the drive bevel gear and driven bevel gear as a set and readjust the tooth contact.

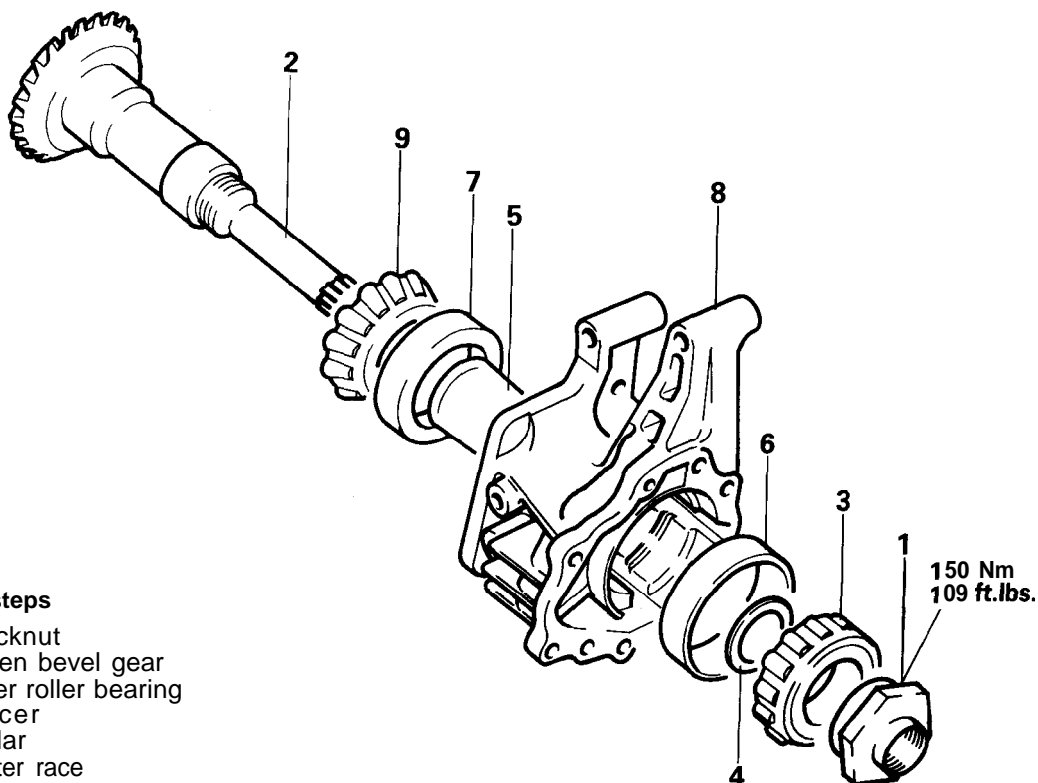
TRANSFER CASE ADAPTER – 4WD**DISASSEMBLY AND REASSEMBLY****Disassembly steps**

- ◁A▷ ▷B◁ 1. Locknut
- ◁B▷ ▷D◁ 2. Driven bevel gear
- ▷C◁ 3. Taper roller bearing
- ▷B◁ 4. Spacer
- 5. Collar
- ◁C▷ 6. Outer race
- ◁C▷ 7. Outer race
- 8. Transfer case adapter
- ◁D▷ ▷A◁ 9. Taper roller bearing

TEA0604

DISASSEMBLY SERVICE POINTS**◁A▷ LOCKNUT REMOVAL**

- (1) Unlock the lock nut. (Straighten the bent nut.)

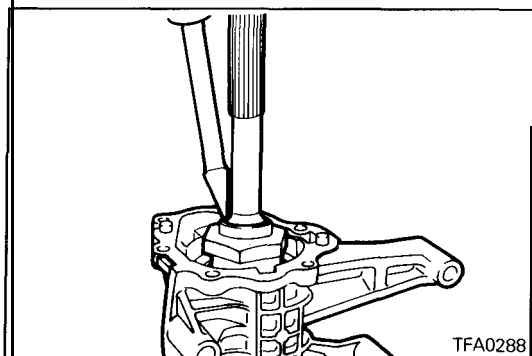

TFA0288

- (2) Holding the driven bevel gear in a vice and using the special tool, remove the lock nut.

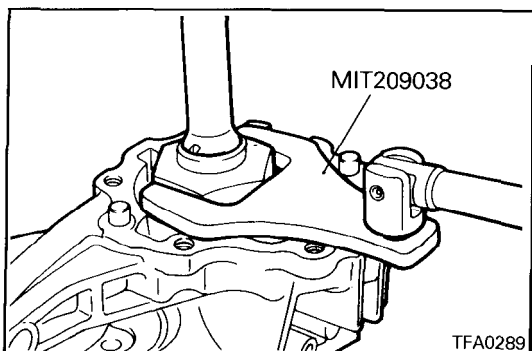

TFA0289

TSB Revision

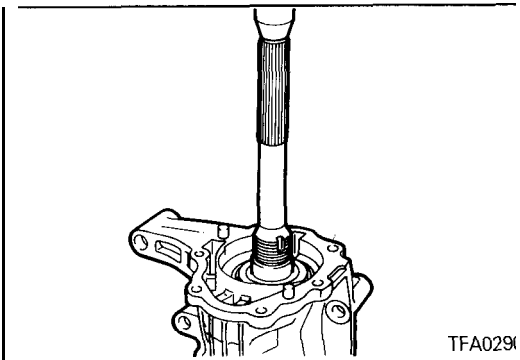

◁B▷ DRIVEN BEVEL GEAR ASSEMBLY REMOVAL

(1) Using a press, remove the driven bevel gear assembly.

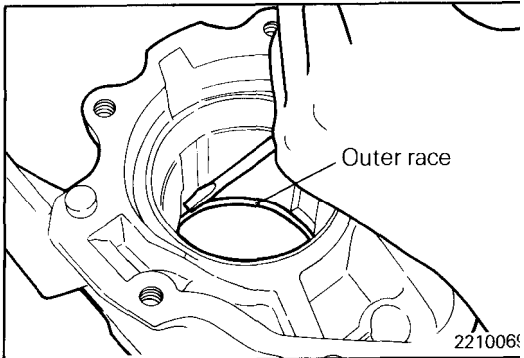

◁C▷ OUTER RACE REMOVAL

(1) Remove the outer race, striking lightly with a screwdriver, etc.

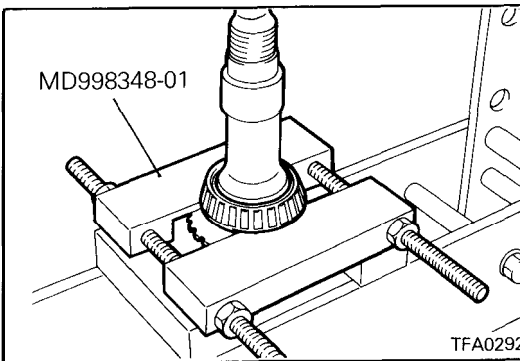

◁D▷ TAPER ROLLER BEARING REMOVAL

REASSEMBLY SERVICE POINTS

▷A◁ TAPER ROLLER BEARING INSTALLATION

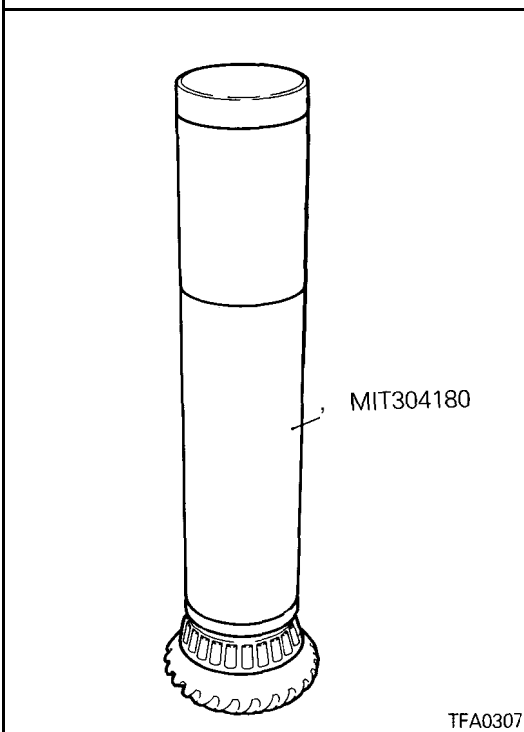

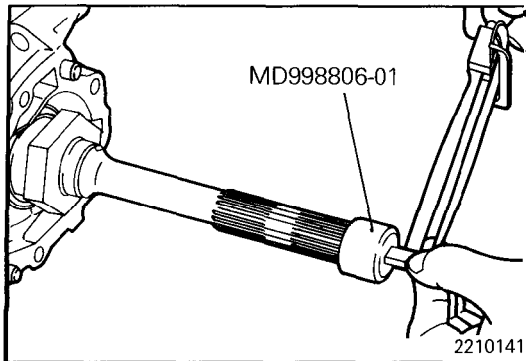

◆B◆ SPACER SELECTION

- (1) Use the existing spacer to assemble the transfer case adapter.
- (2) Using the special tool, check that the bevel gear rotating drive torque is within standard range.

Standard value: 1.0 – 1.7 Nm (.72 – 1.23 ft.lbs.)

- (3) If the rotating drive torque is outside of the standard range, adjust using adjusting spacers.

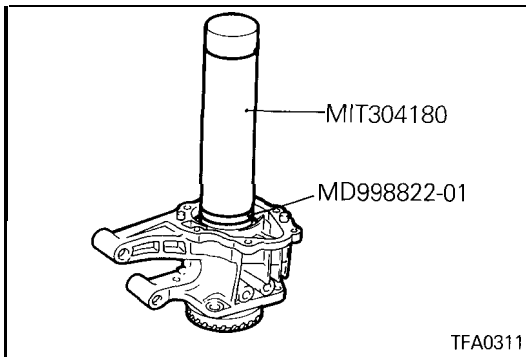

◆C◆ TAPER ROLLER BEARING INSTALLATION

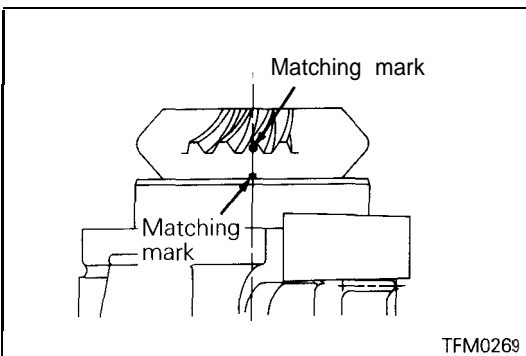

◆D◆ DRIVEN BEVEL GEAR INSTALLATION

- (1) Attach the driven bevel gear to the transfer case adapter and then align their matching marks.

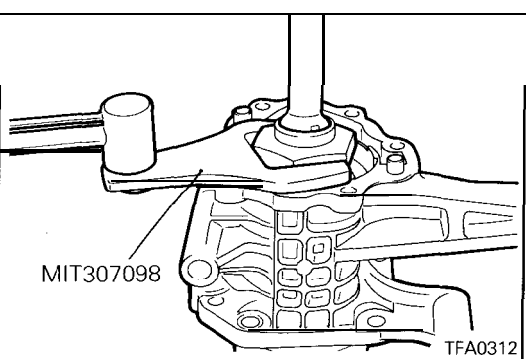

◆E◆ LOCK NUT INSTALLATION

- (1) Holding the driven bevel gear in a vice and using the special tool, tighten the lock nut to specified torque.

Driven bevel gear lock nut: 150 Nm (108 ft.lbs)

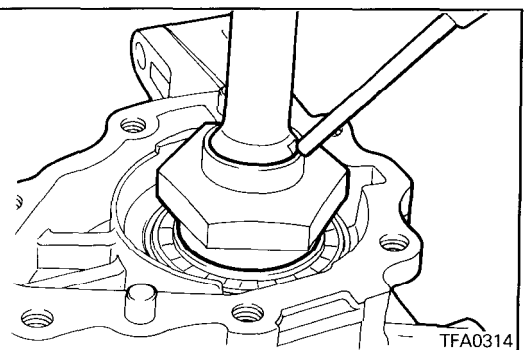

- (2) Lock the lock nut at two positions.

TRANSFER CASE – 4WD

DISASSEMBLY AND REASSEMBLY

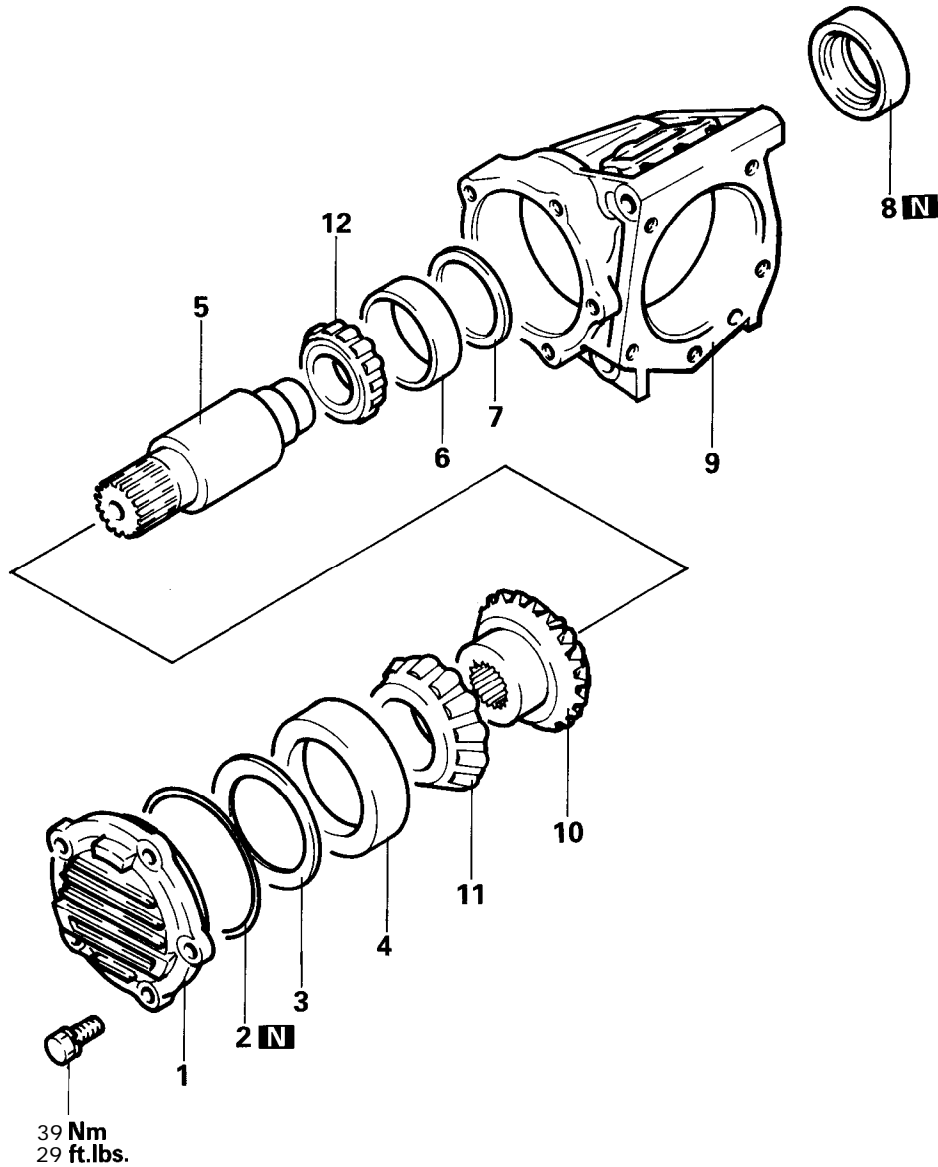

Disassembly steps

1. Transfer cover
2. O-ring
- ▶E▶ 3. Spacer
- ▶D▶ 4. Outer race
- ▶D▶ 5. Drive bevel gear shaft
6. Outer race
- ▶E▶ 7. Spacer
- ▶C▶ 8. Oil seal
9. Transfer case
- ▶B▶ 10. Drive bevel gear
- ◁A▶▶A▶ 11. Taper roller bearing
- ◁A▶▶A▶ 12. Taper roller bearing

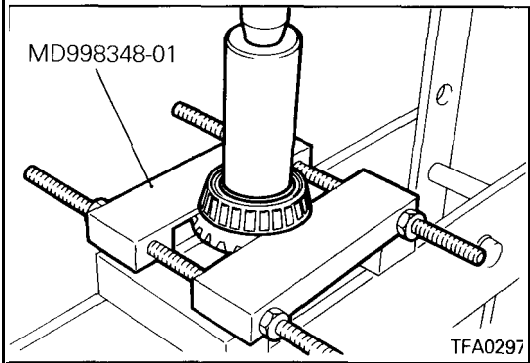

DISASSEMBLY SERVICE POINT

◊A◊ TAPER ROLLER BEARINGS REMOVAL

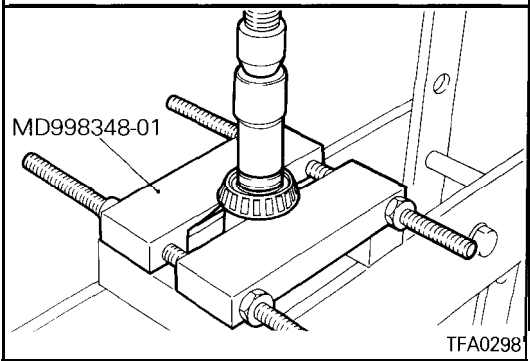

REASSEMBLY SERVICE POINTS

◆A◆ TAPER ROLLER BEARING INSTALLATION

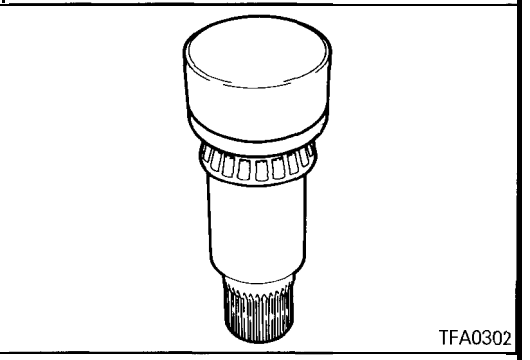
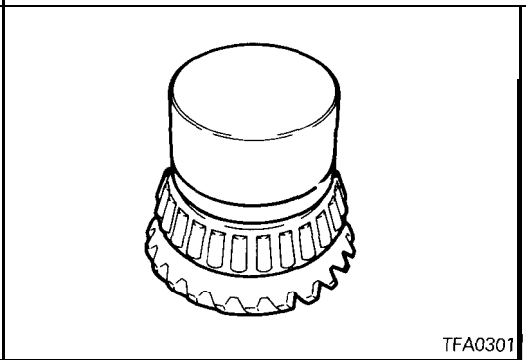

◆B◆ DRIVE BEVEL GEAR INSTALLATION

- (1) Install the drive bevel gear to the drive bevel gear shaft with their matching marks in alignment.

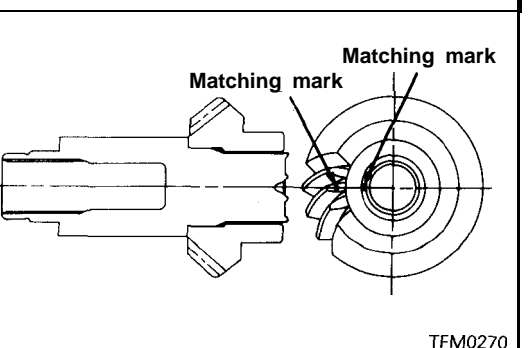

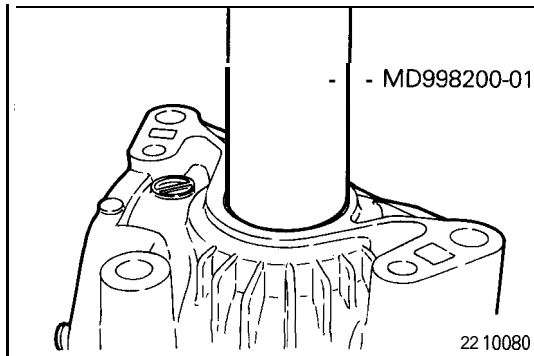

◆C◆ OIL SEAL INSTALLATION

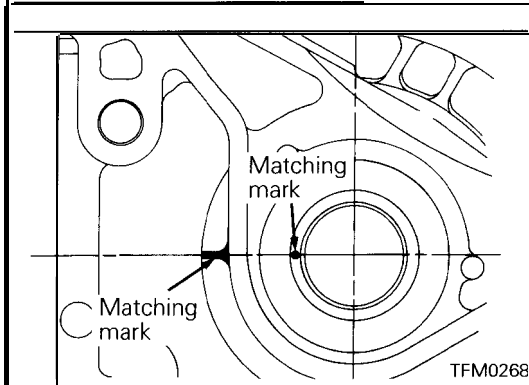

◆D◆ DRIVE BEVEL GEAR SHAFT INSTALLATION

- (1) Install the drive bevel gear shaft to the transfer case and align the matching mark on the transfer case with that on the drive bevel gear shaft.

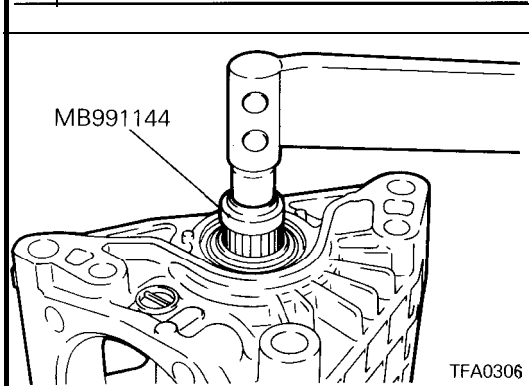

◆E◆ SPACER SELECTION

- (1) Use the existing spacer to assemble the transfer case.
- (2) Using the special tool, check that the bevel gear rotating drive torque is within standard range.

Standard value: 1.7 – 2.5 Nm (1.23 – 1.81 ft.lbs.)

- (3) If the rotating drive torque is outside of the standard range, adjust using adjusting spacers.

NOTE

For adjustment, use two spacers of which thickness is as close as possible to each other.

EXTENSION HOUSING – 4WD

DISASSEMBLY AND REASSEMBLY

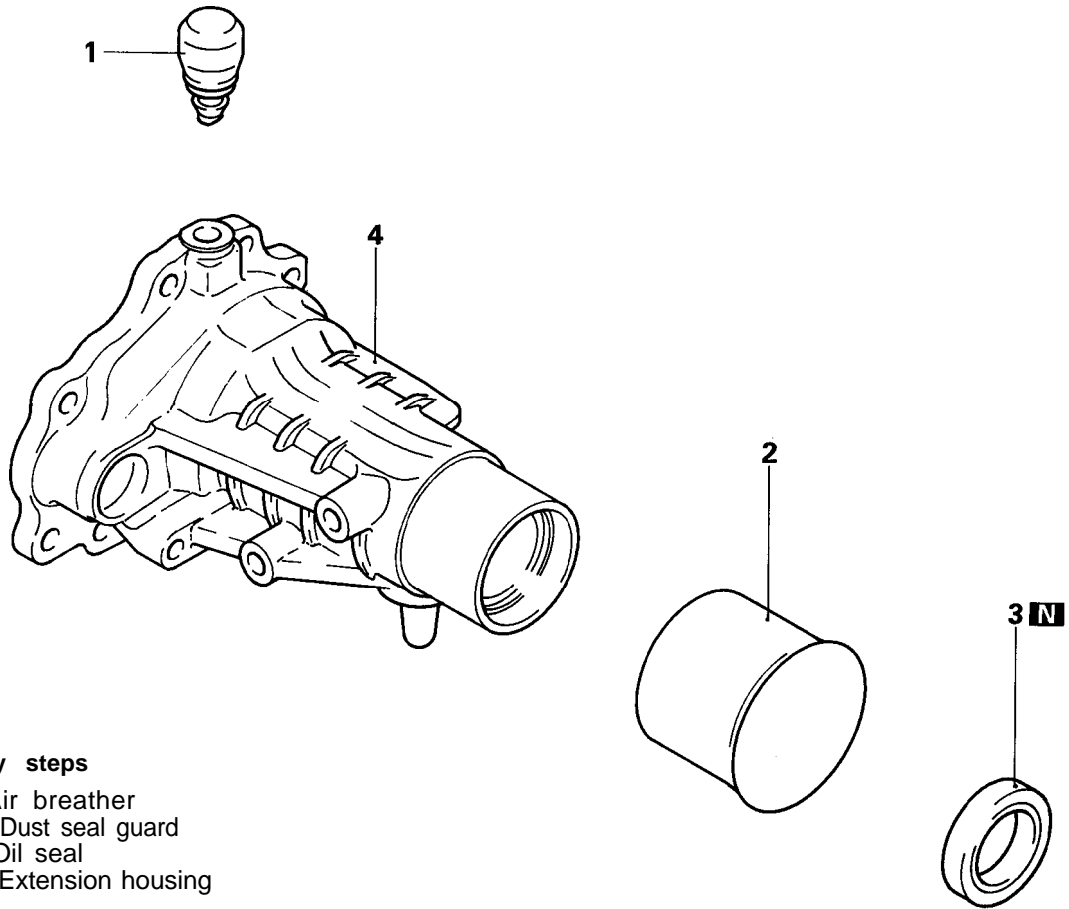

Disassembly steps

- ▶B▶ 1. Air breather
- 2. Dust seal guard
- ▶A▶ 3. Oil seal
- 4. Extension housing

TFA0602

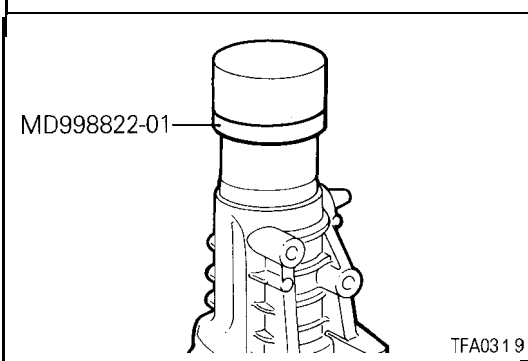

REASSEMBLY SERVICE POINTS

▶A▶ OIL SEAL INSTALLATION

▶B▶ AIR BLEEDER INSTALLATION

- (1) Install the air bleeder applying sealant to the inserting portion.

Specified sealant:

3M SUPER WETHERSTRIP No. 8001 or equivalent

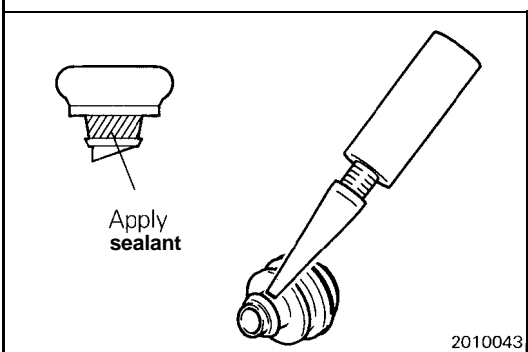

OIL PUMP DRIVE GEAR – F4A33-1-MNN5, MNPE

DISASSEMBLY AND REASSEMBLY

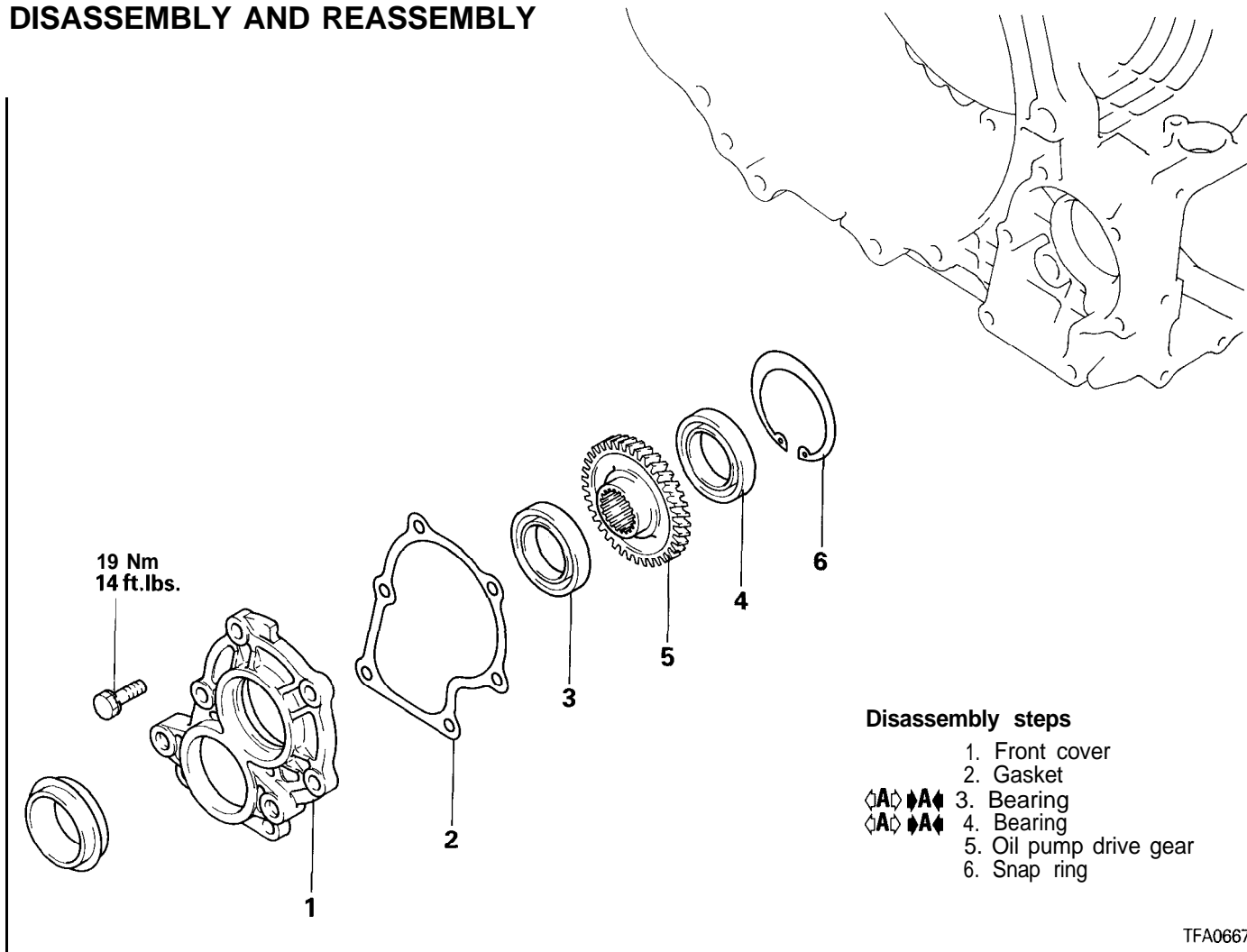

TFA0667

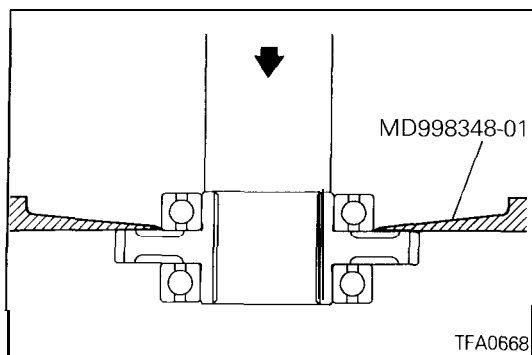

DISASSEMBLY SERVICE POINT

◁A▷ BEARING REMOVAL

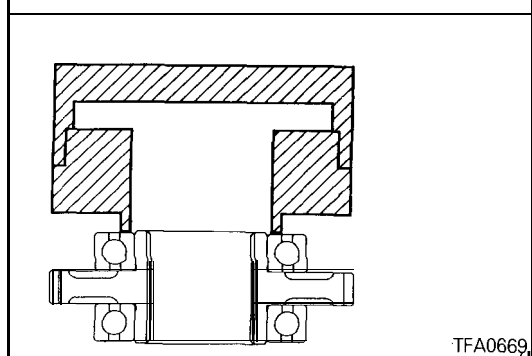

REASSEMBLY SERVICE POINT

▶A BEARING INSTALLATION

NOTES